



PTO-X DRIVEN - GRASS COLLECTION SYSTEM

Model# 23651201



**Predator Pro RS
ProCat MX
& ProCat**

**52" & 61" DECK
MODEL YEAR:**

2019 - Newer



6000 Series, 6000MX Series, 7001 & 7002 Series

OPERATOR'S MANUAL

ASSEMBLY • OPERATION • MAINTENANCE

GRASS COLLECTION SYSTEM

TABLE OF CONTENTS

SECTION	PAGE	SECTION	PAGE
Safety	2	Blower Cone Installation	19
Safety Alert Symbols	3	Boot Kit Installation	19-20
Warranty	4	Length of Hose Adjustment	21
I INTRODUCTION AND DESCRIPTION	5	Upper Hose Installation	21
Introduction	5	Lower Hose to Blower Cone Installation	21
Description	5	Lower Hose to Boot Installation	21
II INSTALLATION FOR USE	6	Wire Harness Installation	22-24
Preparation Of Mower	6-7	Impeller Blade Removal/Replacement	25
Left Frame Bracket & Top Bracket / Mount Arm Installation	8	Weight Kit Installation	26
Bottom Bracket / Mount Arm Installation	9	Exploded Views & Parts List	27-36
Rear Frame Bracket Installation	9	Overall Parts List	37
Lower Mount Tube Installation	10	Safety Decals	38
Upper Frame Assembly Installation	11	III OPERATING INSTRUCTIONS	39
Receiver Tube / Mount Arm Assembly Installation	12	General Safety	39
PTO Drive Assembly	13-14	Operation & Tips On Mowing	39
Drive Assembly & Belt Installation	15	Disengagement Of The PTO Assembly	39
Lift Handle Installation	16	Unloading The Collection System	39
Aluminum Box Assembly Installation	17	IV MAINTENANCE	39-40
Dump Mechanism Adjustment	17	Maintenance Checklist	40
Inlet, Inlet Ring & Debris Deflector Installation	18	Lubrication	40
		V PARTS AND SERVICE	40
		Parts And Service Information	40
		Torque Specifications	41
		Troubleshooting	42

SAFETY

1. Read the operator's manual carefully and familiarize yourself with the proper use of your attachment. Do not allow anyone who is not acquainted with the Safety Instructions to use your attachment.
2. Know the controls and how to stop them quickly. **READ THE OPERATOR'S MANUAL!**
3. Do not allow children to operate the machine. Do not allow adults to operate it without proper instruction.
4. Be especially watchful of children and pets entering into the area while operating.
5. Keep your eyes and mind on your machine while mowing or operating your attachment. Don't let others distract you.
6. Do not attempt to operate your machine when not in the driver's seat.
7. Always shut off blades and engine when emptying the container.
8. Stop machine, shut off deck attachment, set parking brake, shut off engine and remove ignition key before removing clogs, removing or replacing hose, boot, blower cone, or performing any maintenance.
9. Mow across the face of slopes (not more than 10 degrees); never up and down the face.
10. It is recommended that the container be emptied when half full while operating on slopes. Start mowing on slopes when the container is empty.
11. Inspect your lawn and remove any foreign objects before mowing. Never deliberately run the mower across any foreign object.
12. Wear hearing protection.
13. Wear eye protection to prevent debris from getting into your eyes.

SAFETY

WARNING! NEVER operate the mower unless the discharge guard and either the deflector assembly or the vacuum collector adapter are fastened securely in place.

WARNING! Do not work around the mower deck boot or the blower area until you are certain that the mower blades and the blower impeller have stopped rotating.

WARNING! To avoid serious injury, perform maintenance on the vacuum collector; **ONLY AFTER STOPPING THE MOWER'S ENGINE AND WAITING FOR ALL MOVING PARTS TO COME TO A COMPLETE STOP.** Set the parking brake. Always remove the ignition key before beginning maintenance.

WARNING! For your own personal safety, **ALWAYS mow ACROSS the face of slopes and NEVER UP and DOWN the face. NEVER attempt to mow excessively steep slopes, and use caution when turning on any slope.**

Safety Alert Symbol



This Safety Alert Symbol means: **“ATTENTION! BECOME ALERT! YOUR SAFETY IS INVOLVED!”**

This symbol is used to call attention to safety precautions that should be followed by the operator to avoid accidents. When you see this symbol, carefully read the message that follows and heed its advice. Failure to comply with safety precautions could result in death or serious bodily injury.

Safety Signs

The signal words **DANGER**, **WARNING**, and **CAUTION** are used on the equipment safety signs. These words are intended to alert the viewer to the existence and the degree of hazard seriousness.



White letters on **RED**

This signal word indicates a potentially hazardous situation which, if not avoided, will result in death or serious injury.



Black letters on **ORANGE**

This signal word indicates a potentially hazardous situation which, if not avoided, could result in death or serious injury.

It may also be used to alert against unsafe practices.



Black letters on **YELLOW**

This signal word indicates a potentially hazardous situation which, if not avoided, will result in minor or moderate injury.

It may also be used to alert against unsafe practices.

PECO LIMITED WARRANTY FOR NEW PRODUCTS

New PECO, Inc. extends the following warranties to the ORIGINAL PURCHASER of each New PECO, Inc. consumer product purchased from one of our Dealers or directly from New PECO, Inc., subject to the following limitations:

A. ITEMS COVERED UNDER WARRANTY

1. **PRODUCT WARRANTY** – Any part or parts which are deemed defective in material or workmanship, as delivered to the original purchaser, will either be repaired or replaced, as New PECO, Inc. elects, without charge for parts or labor, if the defect appears within 12 months from the date of purchase of the product to the Original Purchaser.
2. **PARTS REPLACED DURING WARRANTY** – Any New PECO, Inc. part which is furnished in performance of this warranty and is defective in material or workmanship as delivered to the purchaser will be repaired or replaced, as New PECO, Inc. elects, before the expiration of the original warranty period.

B. WARRANTY DISTINCTIONS

1. **RESIDENTIAL** - Products put to a personal use around a single household or residence are considered Residential. Products designated as “Residential” are warranted for 12 months from the date of purchase of the product, to the ORIGINAL PURCHASER with proof of purchase, when used for or in residential applications.
2. **COMMERCIAL** – Products put to any business use (agricultural, commercial or industrial) or used at multiple locations are considered Commercial. Products designated as “Commercial” are warranted for 12 months from the date of purchase of the product, to the ORIGINAL PURCHASER with proof of purchase, when used for or in commercial applications. Products designated as “Residential” are warranted for 90 days from the date of purchase of the product, to the ORIGINAL PURCHASER with proof of purchase, when used for or in Commercial applications.
3. **RENTAL** – Products used for Rental or Lease Purposes are warranted for 45 days from date of purchase of the product, to the ORIGINAL PURCHASER with proof of purchase, when used for or in a rental business.

C. ITEMS NOT COVERED BY NEW PECO WARRANTY

1. **ENGINES & BATTERIES:** Engines and Batteries attached to New PECO, Inc. products are covered under their respective separate manufacturer warranties and those companies must be contacted directly to file a warranty claim. Briggs & Stratton: https://www.briggsandstratton.com/na/en_us/support/warranty.html
2. **UNAPPROVED ALTERATION OR MODIFICATION:** All obligations of New PECO, Inc. under this warranty shall be terminated if products are altered or modified in any way not approved by New PECO, Inc.
3. **ACCIDENTS & NORMAL MAINTENANCE:** This warranty covers ONLY manufacturers defective material and workmanship. It does not cover depreciation or damage caused by normal wear & tear, accident, improper maintenance, misuse or abuse of products. New PECO, Inc. products must be operated and maintained in accordance with the instructions furnished in the manuals. The cost of normal maintenance and normal replacement of service items such as belts, cutting blades, hoses, bags, etc., which are not defective shall be paid for by the purchaser.
4. **NO SERVICE CENTER WARRANTY:** The selling Service Center/Dealer makes no warranty on his own on any item warranted by New PECO, Inc. unless he delivers to purchaser a separate written warranty certificate specifically warranting the item. The Service Center or Dealer has no authority to make any representation or promise on behalf of New PECO, Inc. or to modify the terms of the original warranty in any way.
5. **NO REPRESENTATIONS ADDITIONAL WARRANTIES, DISCLAIMER:** Neither New PECO, Inc. nor any company affiliated with New PECO, Inc. makes any warranties, representations or promises as to the quality of performance of its products other than those set forth herein. Except as described above, New PECO, Inc. makes no other warranties **AND SPECIFICALLY DISCLAIMS ANY AND ALL IMPLIED WARRANTIES OF FITNESS AND MERCHANTABILITY.**
6. **REMEDIED EXCLUSIVE:** The only remedies the purchaser has in connection with the breach or performance of any warranty on New PECO, Inc. consumer products are set forth above. In no event will New PECO, Inc. be liable for special incidental or consequential damages.

Warranty service is available through your local authorized service dealer or distributor. If you do not know the dealer or distributor in your area, search by your zip code on www.lawnvac.com or contact our Sales Department at New PECO, Inc. 800-438-5823 or email Sales@lawnvac.com.

Section I - INTRODUCTION AND DESCRIPTION

Introduction

We are pleased to have you as a PECO customer. Your collection system has been designed to give you a low maintenance, simple, and effective way to collect the grass clippings from your mower. The manuals are provided to give you the necessary instructions to properly mount, operate and maintain the collection system on your mower. Please read this manual thoroughly. Understand what each control is for and how to use it. Observe all safety decal precautions on the machine and noted throughout the manual.

NOTE: All references made to right, left, front, rear, top or bottom are as viewed from the normal operator's position on the mower.

Description

The grass collection system is designed for turf maintenance where there is a need to collect the grass clippings as the mower cuts the turf. It is also used for picking up leaves in pre-season and post-season clean-up. The blower, mounted on the right side of the unit, uses a belt and gearbox system from the engine PTO shaft. Drive train protection comes through belt slippage. The blower draws grass clippings from the discharge area of the cutting deck back to the collection bags at the rear portion of the mower frame. The operator can engage the blower by switching the PTO Switch to the ON position. Once the collection unit is full with clippings, it can be easily released for dumping.



Section II - INSTALLATION FOR USE

Preparation Of Mower

NOTE: The mower deck PTO belt must be removed from the electric clutch before continuing with the installation. Refer to your mower's owner's manual for instructions on PTO belt removal.

NOTE: Engine Pulley Installation is for PTO Models only.

From the underside of the engine, disconnect the wiring harness attached to the electric clutch. Remove the bolt and electric clutch from the mower. Refer to Figure A.

Figure A

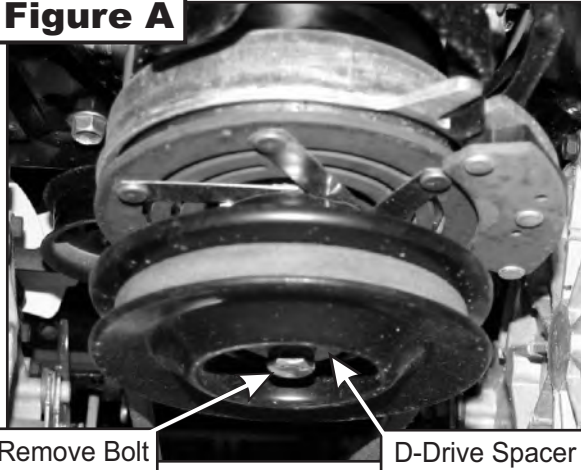

Upon removal of clutch determine if your mower is equipped with a D-drive spacer. If so, proceed to Figure B. If your mower is equipped with a bolt, fender and lock washer without D-drive spacer proceed to Figure C. Remove the D-drive spacer using an arbor press or equivalent. On removal, adjacent bearing OUTER race must be supported or bearing damage may occur. Refer to Figure B.

Figure B

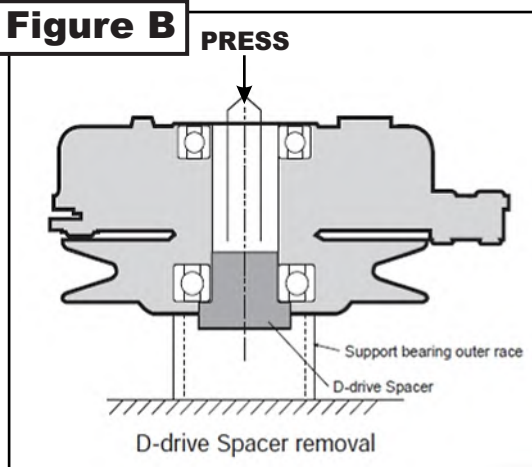
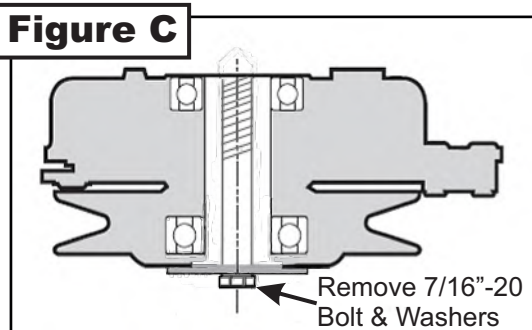
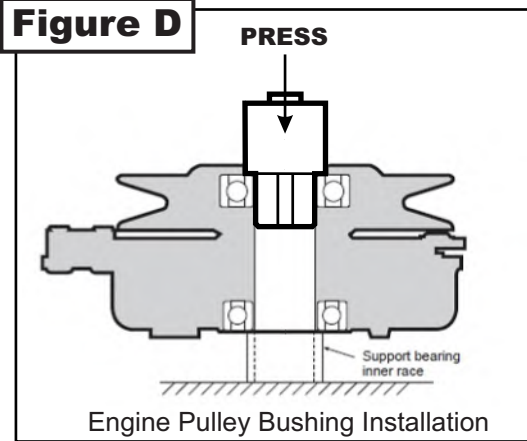

Figure C



The engine pulley assembly must be installed using an arbor press or equivalent. During installation, opposite bearing inner race must be supported or bearing damage may occur. Refer to Figure D.

Figure D



Once the Engine Pulley Bushing is installed, reattach the clutch assembly & deck PTO belt to the mower and then review Figure E.

Figure E

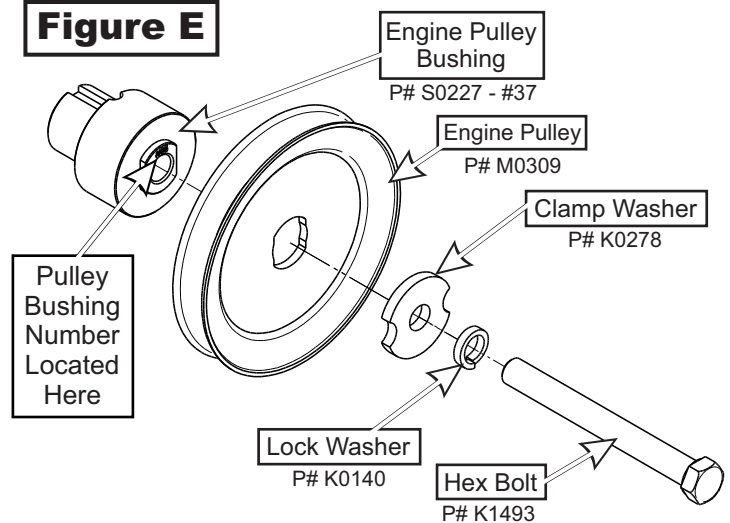

To assemble and fasten the Engine Pulley, align the Engine Pulley Bushing to the mower's clutch pulley and fasten using (1) Clamp Washer, (1) Lock Washer, and (1) Hex Bolt. Torque the bolt to 55 ft./lbs. The added pulley will power the collection system and should resemble Figure F when installed.

Figure F

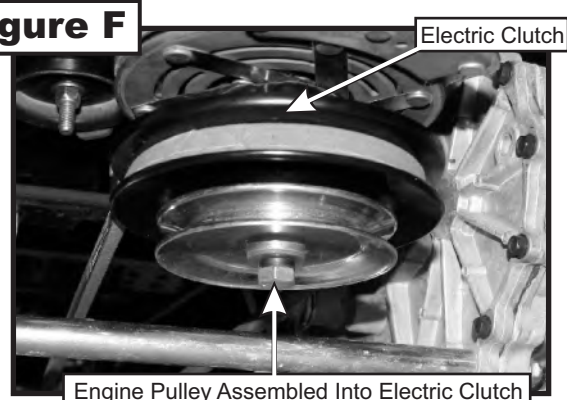

Preparation of Mower (Continued)

Before installing your Grass Collection Unit, remove the mower's rear bumper, and if applicable, the lower hardware securing the oil cooler. Refer to Figures A and B below.

After removing the lower hardware securing the oil cooler, gently lift the oil cooler up and over the engine towards the rear of the operator's seat.

Note: Some parts and features have been hidden from view for visual clarity.

Figure A

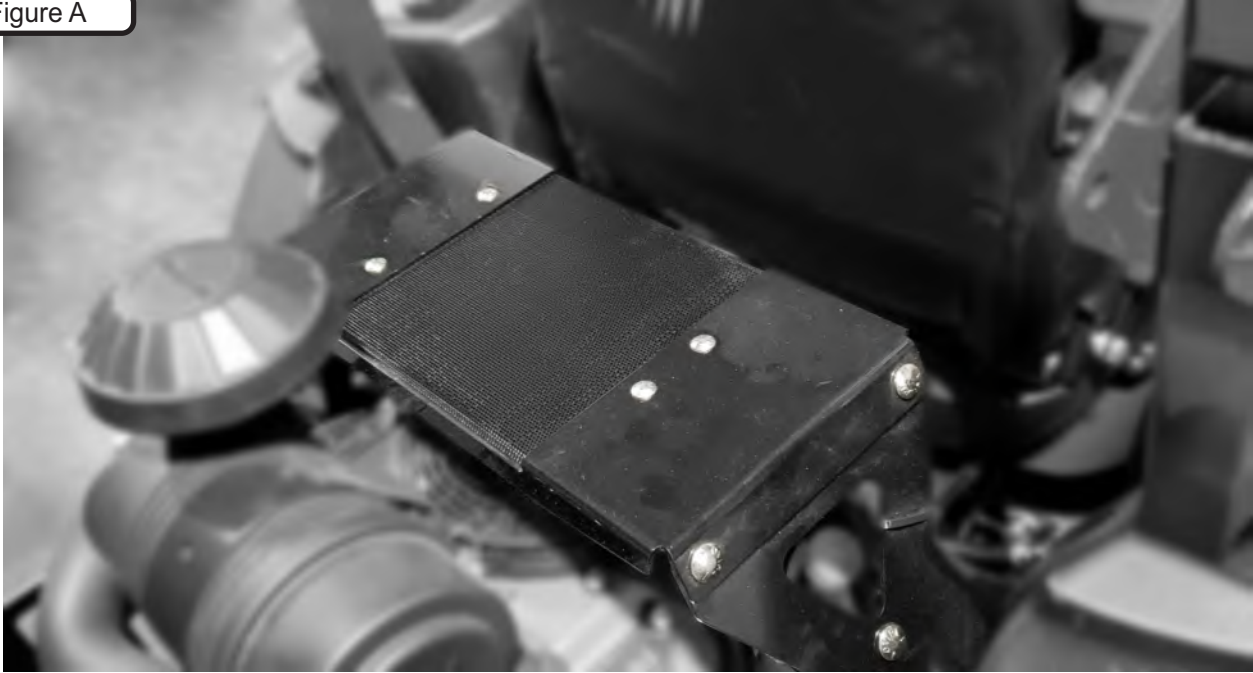

Note: Set aside the lower hardware used to secure the oil cooler as it will be reinstalled later.

Figure B

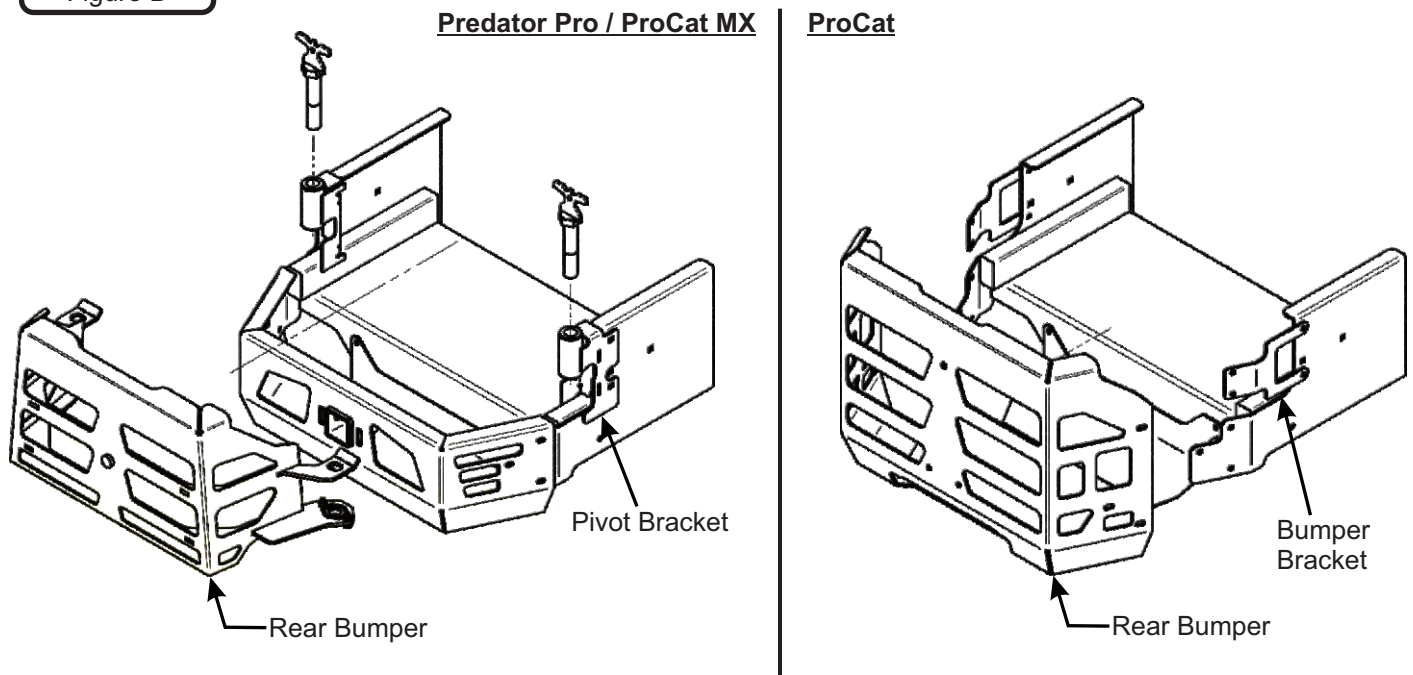

Note: When removing the bumper, do not remove the Pivot Brackets or the Bumper Brackets.

Left Frame Bracket & Top Bracket / Mount Arm Installation

Position the Left Frame Bracket (Item #2) to the left side of the mower and align the bolt holes of the Left Frame Bracket to those of the left rear mower. If applicable, before securing the Left Frame Bracket, reposition and align the left side of the lower oil cooler bracket holes. Then secure the Left Frame Bracket and the left side of the lower oil cooler bracket by using (2) 3/8"-16 x 1-1/4" Carriage Bolts (Item #3), (2) 3/8"-16 Ny-Flange Lock Nuts (Item #4) and the previously removed hardware. Refer to Figure A Below.

Next, position the Top Bracket / Mount Arm (Item #1) to the right side of the mower and align the bolt holes of the Top Bracket / Mount Arm to those of the right rear mower. If applicable, before securing the Top Bracket / Mount Arm, reposition and align the right side of the lower oil cooler bracket holes. Then secure the Top Bracket / Mount Arm and the right side of the lower oil cooler bracket by using (2) 3/8"-16 x 1-1/4" Carriage Bolts (Item #3), (2) 3/8"-16 Ny-Flange Lock Nuts (Item #4) and the previously removed hardware. Refer to Figure A Below.

Note: Some parts and features have been hidden from view for visual clarity.

Leave all hardware relatively loose until the end of the Rear Frame Bracket Installation on the next page.

Figure A

Item #	Part #	Desc.	Qty.
1	B1938	Top Bracket / Mount Arm	1
2	B1941	Left Frame Bracket	1
3	K1183	Carriage Bolt 3/8"-16 x 1-1/4"	4
4	K2038	Ny-Flange Lock Nut 3/8"-16	4

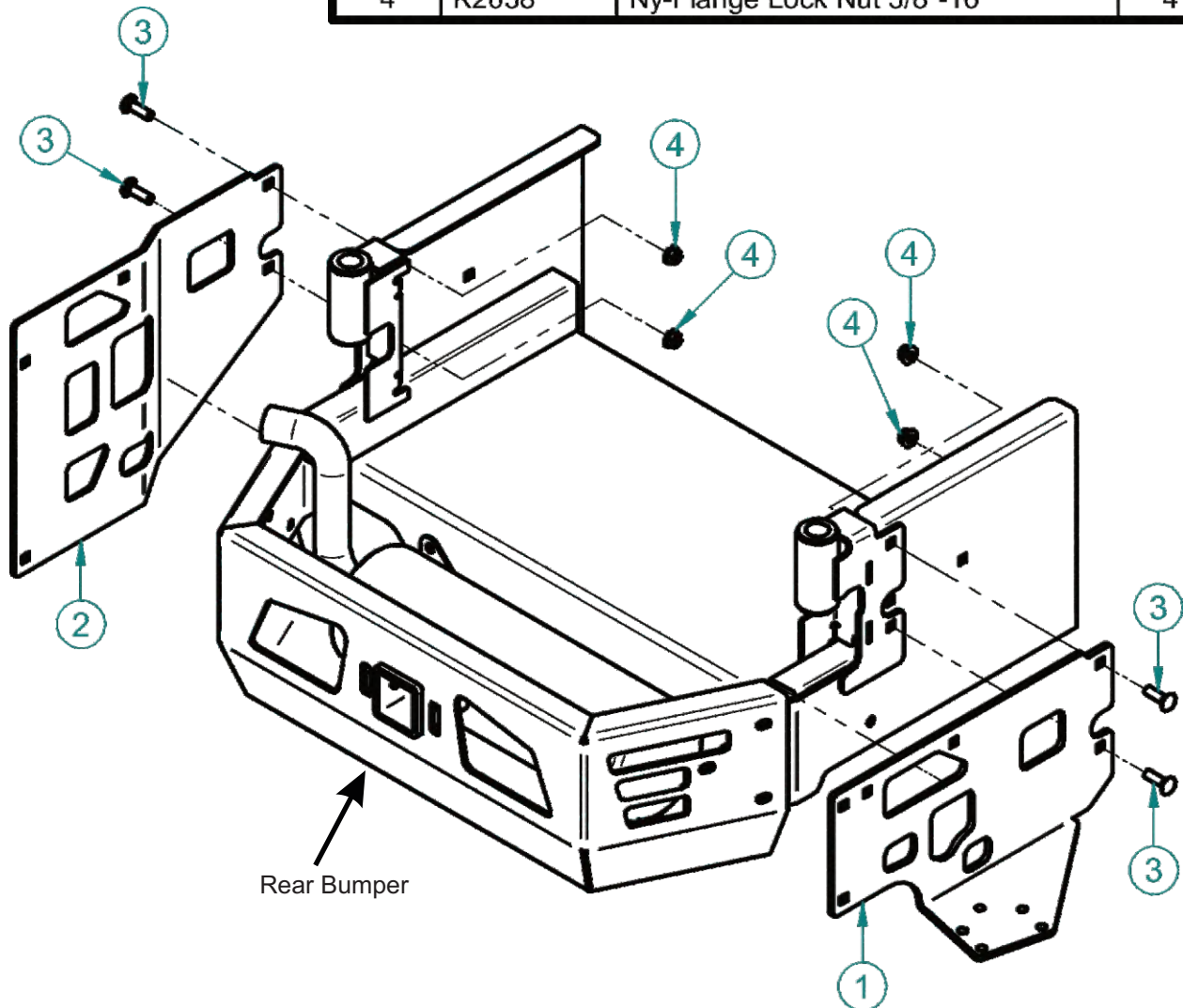

**Leave Hardware
Loose**

Bottom Bracket / Mount Arm Installation

Position the Bottom Bracket / Mount Arm (Item #1) under the Top Bracket / Mount Arm and align the bolt holes of the Bottom Bracket / Mount Arm to the bolt holes located on the bottom right rear of the mower. Refer to Figure A. Secure the Bottom Bracket / Mount Arm by using (3) 3/8"-16 x 1-1/4" Carriage Bolts (Item #2) and (3) 3/8"-16 Ny-Flange Lock Nuts (Item #3).

Note: Leave all hardware relatively loose until the end of the next step. Some parts and features have been hidden from view for visual clarity.

Figure A

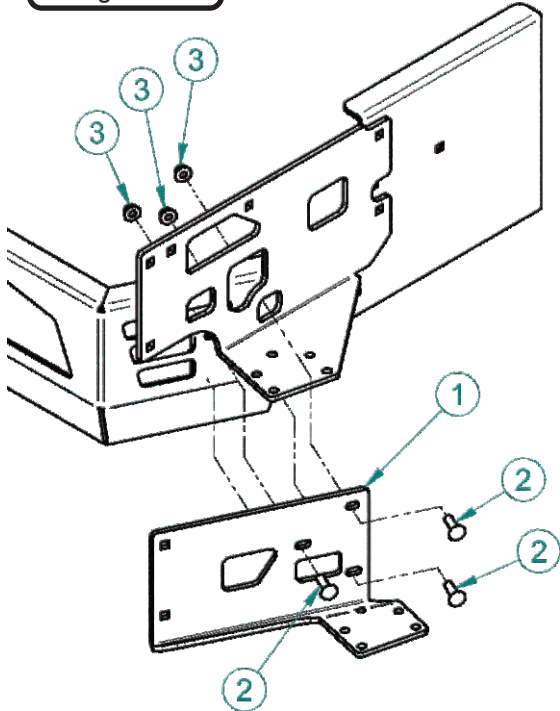

Item #	Part #	Desc.	Qty.
1	B1939	Bottom Bracket / Mount Arm	1
2	K1183	Carriage Bolt 3/8"-16 x 1-1/4"	3
3	K2038	Ny-Flange Lock Nut 3/8"-16	3

Leave Hardware Loose

Bottom Bracket / Mount Arm Positioning

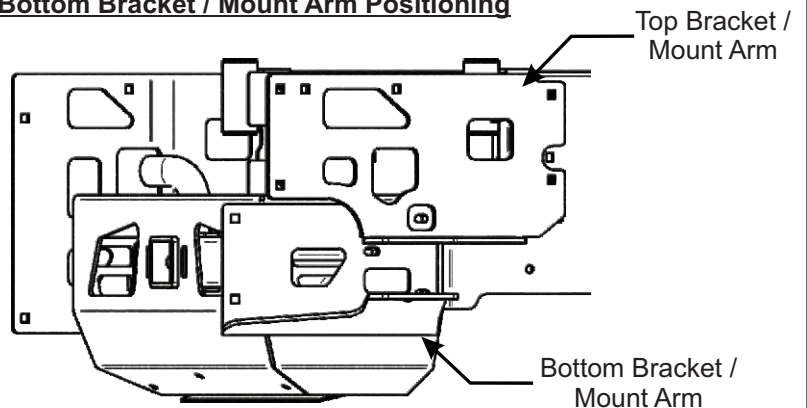

Rear Frame Bracket Installation

Position the Rear Frame Bracket (Item #1) between the Left Frame Bracket & Top Bracket / Mount Arm and align the bolt holes. Loosely secure the Rear Frame Bracket by using (6) 3/8"-16 x 1" Carriage Bolts (Item #2) and (6) 3/8"-16 Ny-Flange Lock Nuts (Item #3). Once the Rear Frame Bracket has been loosely secured, tighten all hardware at this time.

Figure A

Tighten All Hardware at This Time

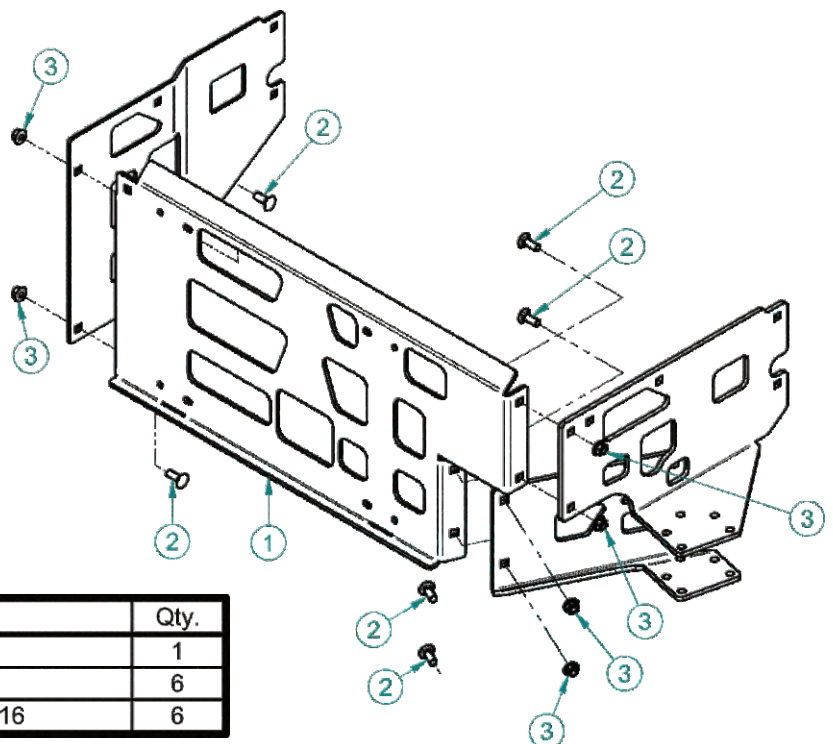

Item #	Part #	Desc.	Qty.
1	B1940	Rear Frame Bracket	1
2	K1182	Carriage Bolt 3/8"-16 x 1"	6
3	K2038	Ny-Flange Lock Nut 3/8"-16	6

Main Frame Legs Installation

To Install the Left Main Frame Leg (Item #1), position and align the bolt holes of the Left Main Frame Leg to those of the Rear Frame Bracket & Left Frame Bracket. Loosely secure the Left Main Frame Leg by using (2) 3/8"-16 x 1" Carriage Bolts (Item #3) and (2) 3/8"-16 Ny-Flange Lock Nuts. Refer to Figure A. Leave hardware relatively loose.

Next, position and align the bolt holes of the Right Main Frame Leg (Item #2) to those of the Top Bracket / Mount Arm. Loosely secure the Right Main Frame Leg by using (2) 3/8"-16 x 1" Carriage Bolts (Item #3) and (2) 3/8"-16 Ny-Flange Lock Nuts. Refer to Figure A. Leave hardware relatively loose until the completion of the Main Frame Assembly Installation on the next page.

Note: Some parts and features have been hidden from view for visual clarity.

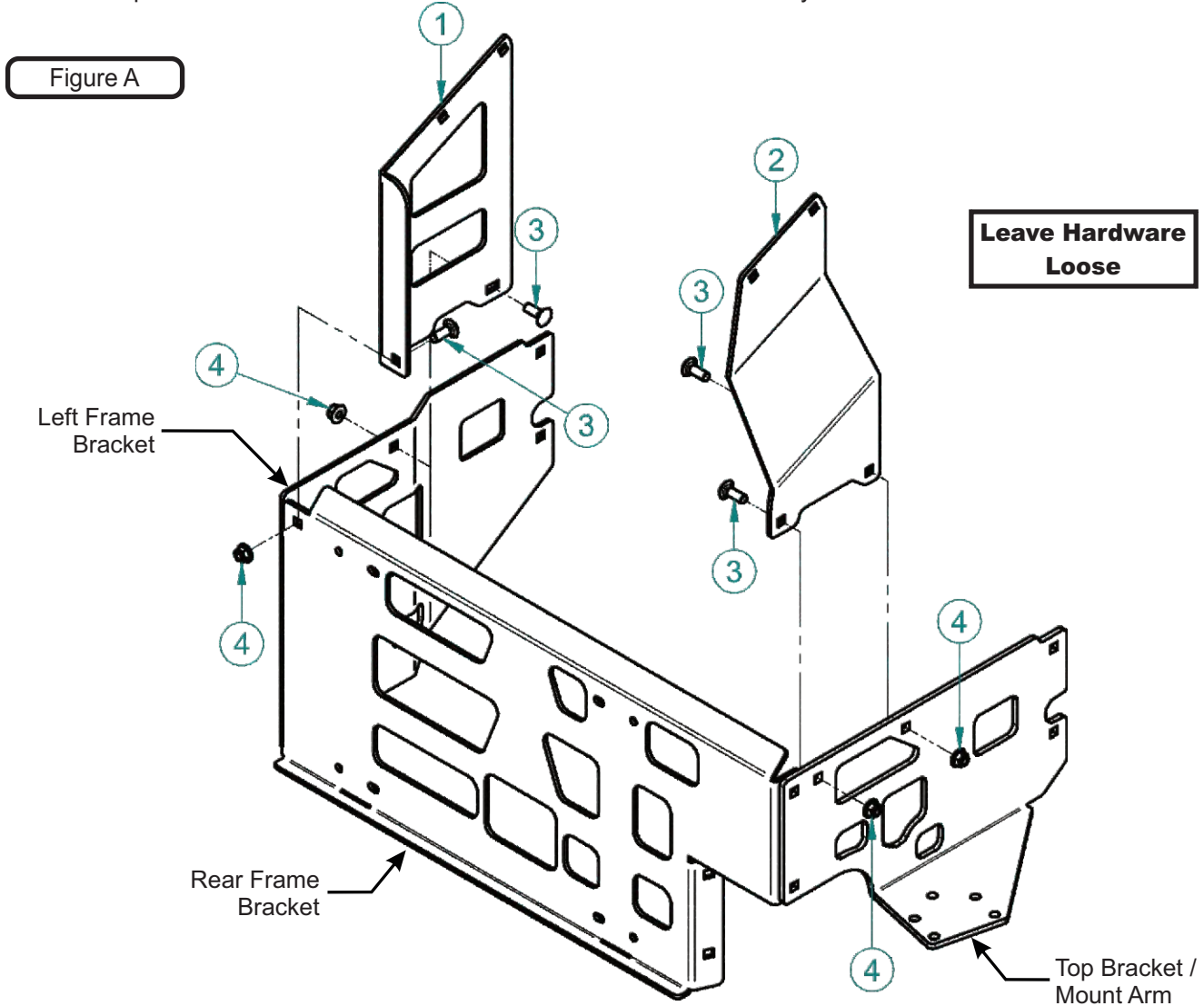

Item #	Part #	Desc.	Qty.
1	B1942	Left Main Frame Leg	1
2	B1943	Right Main Frame Leg	1
3	K1182	Carriage Bolt 3/8"-16 x 1"	4
4	K2038	Ny-Flange Lock Nut 3/8"-16	4

Main Frame Assembly Installation

Position the Main Frame Assembly (Item #1) between the Left & Right Main Frame Legs and align the bolt holes of the Main Frame Assy to those of the Left & Right Main Frame Legs. Loosely secure the Main Frame Assy by using (2) 3/8"-16 x 1" Carriage Bolts (Item #2) and (2) 3/8"-16 Ny-Flange Lock Nuts (Item #3) per side. Refer to Figure A.

Once secured, tighten all hardware at this time.

Note: Some parts and features have been hidden from view for visual clarity.

Figure A

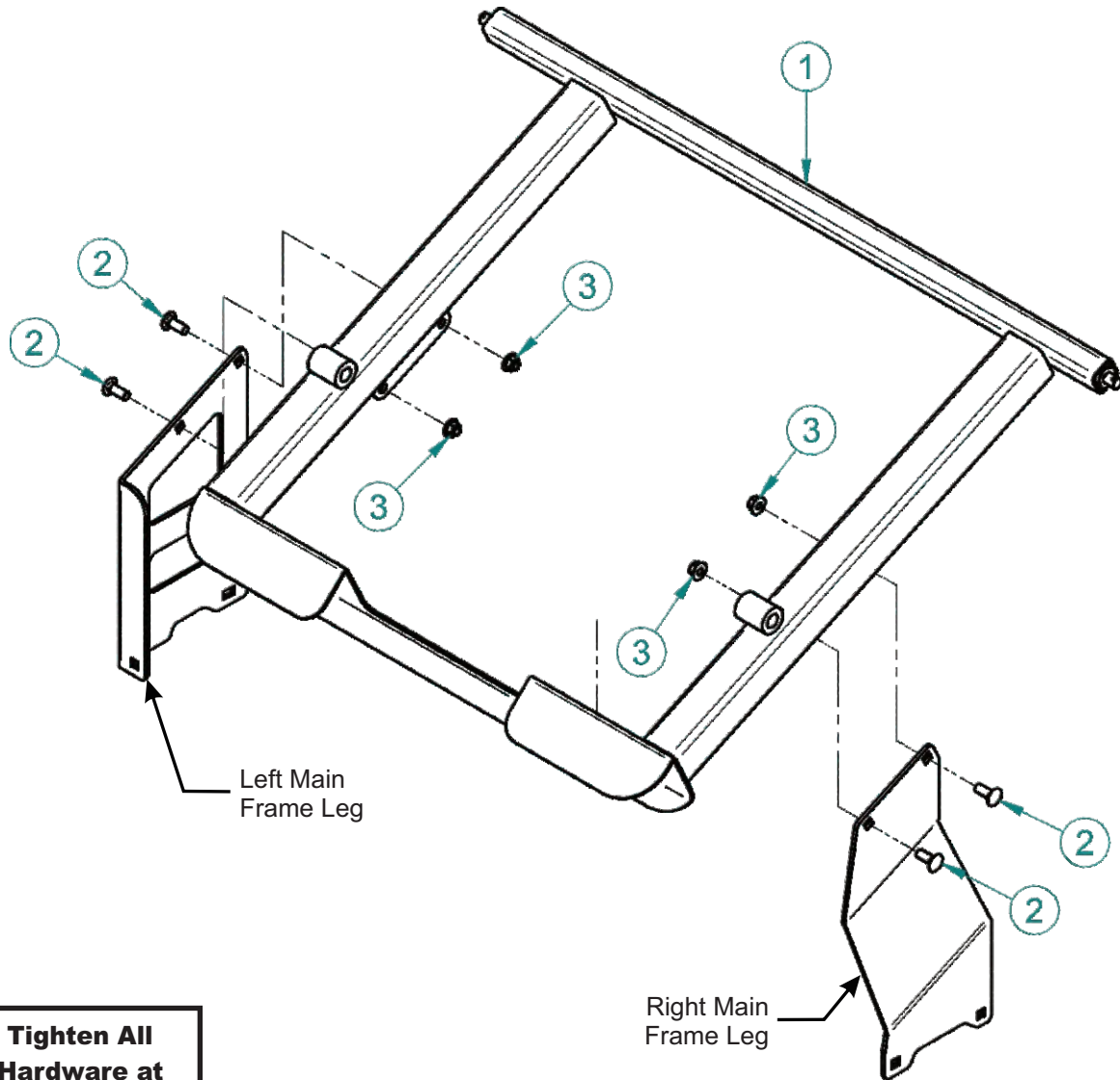

**Tighten All
Hardware at
This Time**

Item #	Part #	Desc.	Qty.
1	A1192	Main Frame Assembly	1
2	K1182	Carriage Bolt 3/8"-16 x 1"	5
3	K2038	Ny-Flange Lock Nut 3/8"-16	4

Receiver Tube Assy / Mount Arm Installation

Prepare the installation of the Receiver Tube Assy / Mount Arm (Item #1) by inserting (1) 3/8"-16 x 3-1/2" HHCS (Item #2) into the rear bolt hole on the horizontal tabs of both the Top & Bottom Bracket / Mount Arm. This will serve as a stop to help position the Receiver Tube Assy. Refer to Figure A.

Next, place the Receiver Tube Assy in between the Top & Bottom Bracket / Mount Arm and push the Receiver Tube Assy in until it is stopped by the HHCS. Secure the Receiver Tube Assy by using (4) 3/8"-16 x 3-1/2" HHCS (Item #2) and (4) 3/8"-16 Ny-Flange Lock Nuts (Item #3). Refer to Figure B.

Once the Receiver Tube Assy is secured, remove the extra 3/8"-16 x 3-1/2" HHCS.

Note: Some parts and features have been hidden from view for visual clarity.

Figure A

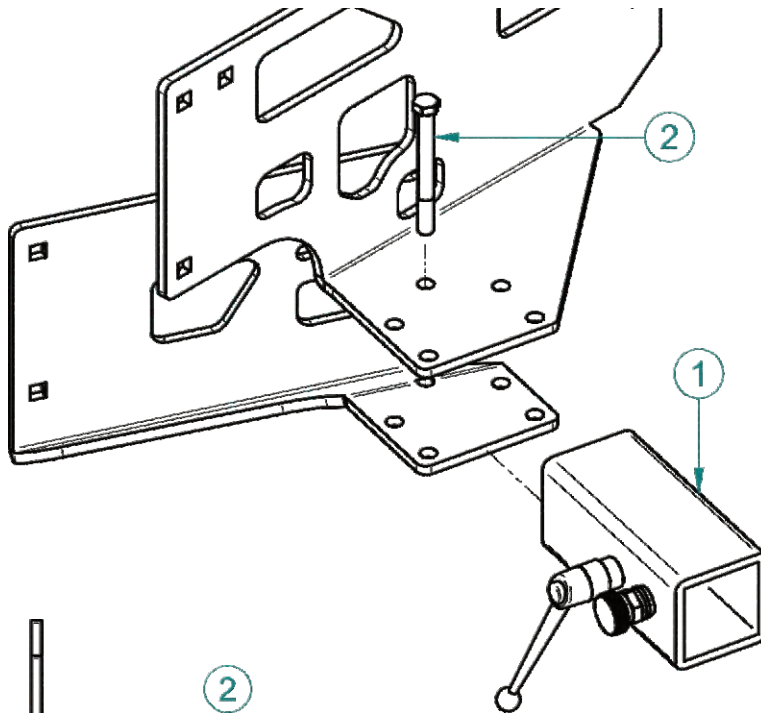
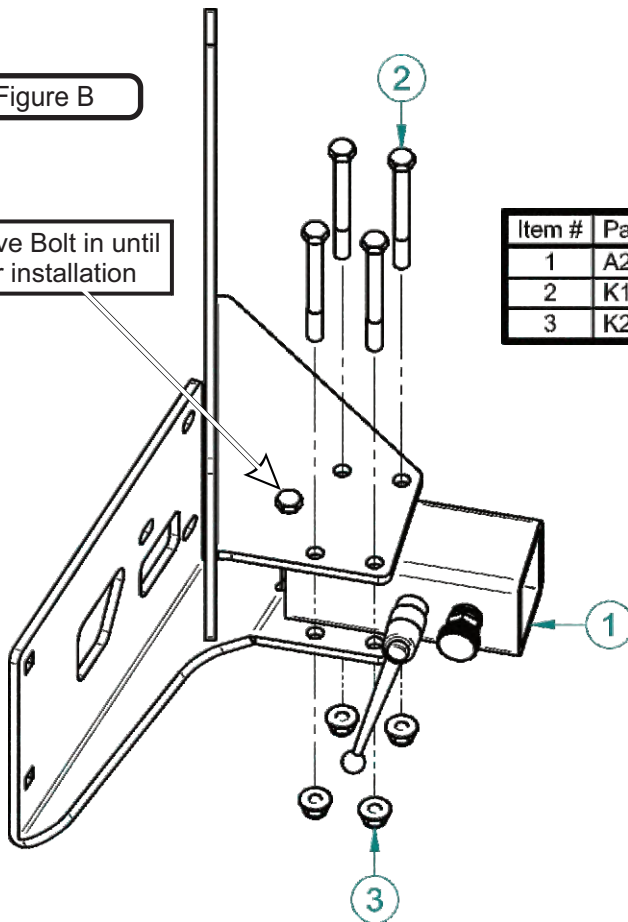

Figure B

Leave Bolt in until after installation



Item #	Part #	Desc.	Qty.
1	A2207	Receiver Tube Assy. / Mount Arm	1
2	K1200	3/8"-16 x 3.5" HHCS G5	4
3	K2038	Ny-Flange Lock Nut 3/8"-16	4

PTO Drive Assembly

Once the Mount Arm Assembly is installed and secured to the mower, assemble the Drive Assembly P#(A2061_01), Belt Guard Assembly P#(A2069_02) & Idler Mount Assembly P#(A2067_02).

First, attach the Belt Guard Assembly P#(A2069_02) to the Drive Assembly P#(A2061_01) using (2) 1/4"-20 x 5/8" Carriage Bolts P#(K1010) and (2) 1/4"-20 Ny-Flange Lock Nuts P#(K2014). Refer to Figure A. **Leave Bolts Loose.**

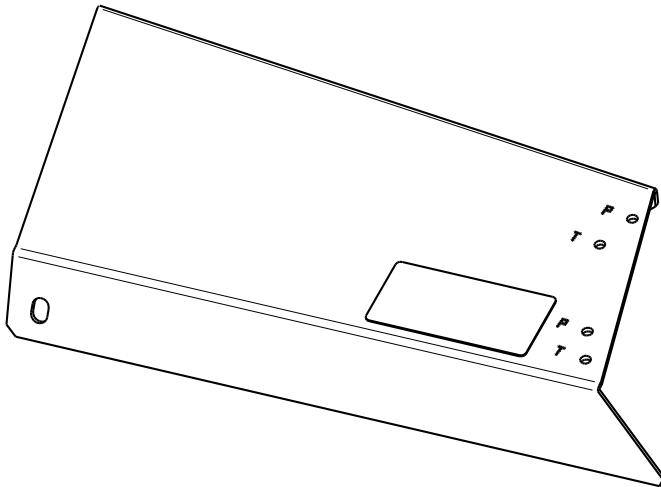

BELT GUARD ASSY. HOLES

Notice Marked Holes Below;
For This Installation, Use Holes
Marked With The Letter 'P'

Figure A

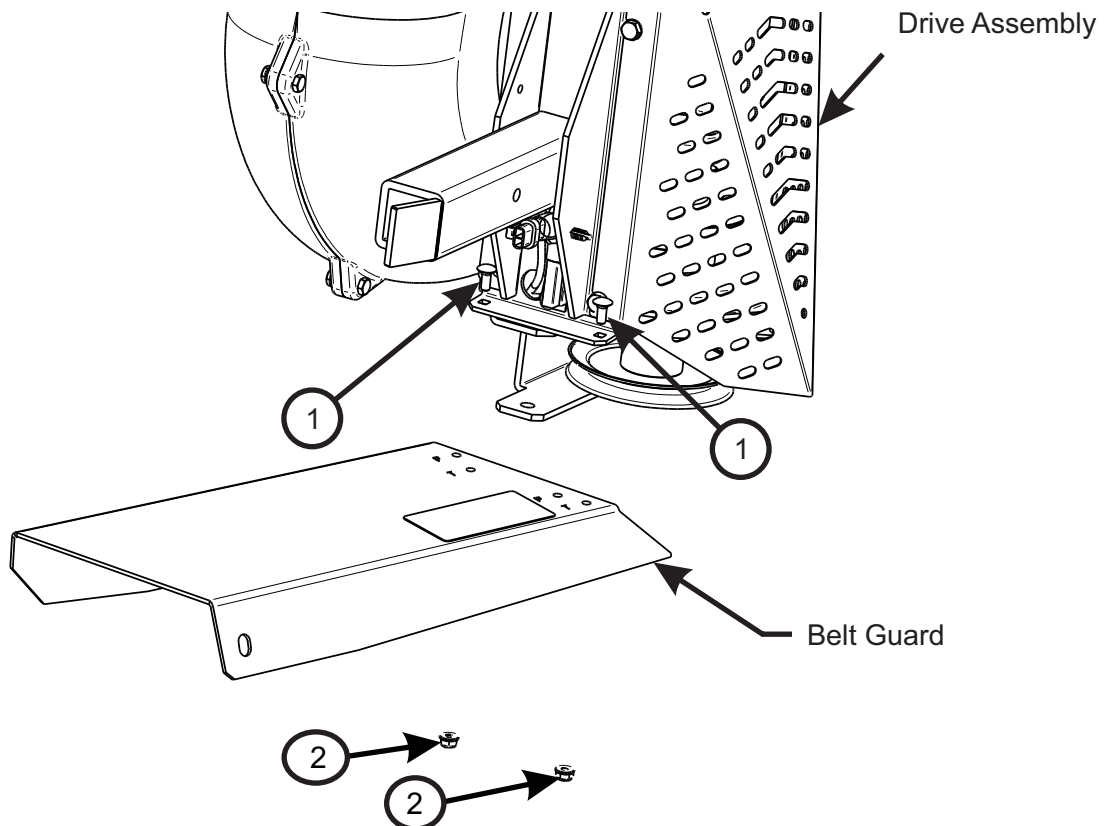

Item #	Part #	Desc.	Qty.
1	K1010	1/4"-20 x 5/8" Carriage Bolt	2
2	K2014	1/4"-20 Ny-Flange Lock Nut	2

PTO Drive Assembly (Continued)

Attach the Idler Mount Assembly P#(A2067_02) to the Drive Assembly using (1) 3/8"-16 x 1" HHCS (A) P#(K1191), (1) 3/8"-16 x 1" Carriage Bolt (B) P#(K1182) and (2) 3/8"-16 Ny-Flange Lock Nuts P#(K2038). Refer to Figure B. Leave Bolts Loose (Note: Orientation of bolts A & B.)

Next, secure the Idler Mount Assembly P#(A2067_02) to the Belt Guard Assembly P#(A2069_02) using (2) 3/8"-16 x 1" Carriage Bolts P#(K1182) and (2) 3/8"-16 Ny-Flange Lock Nuts P#(K2038). Refer to Figure C & D. Tighten All Bolts.

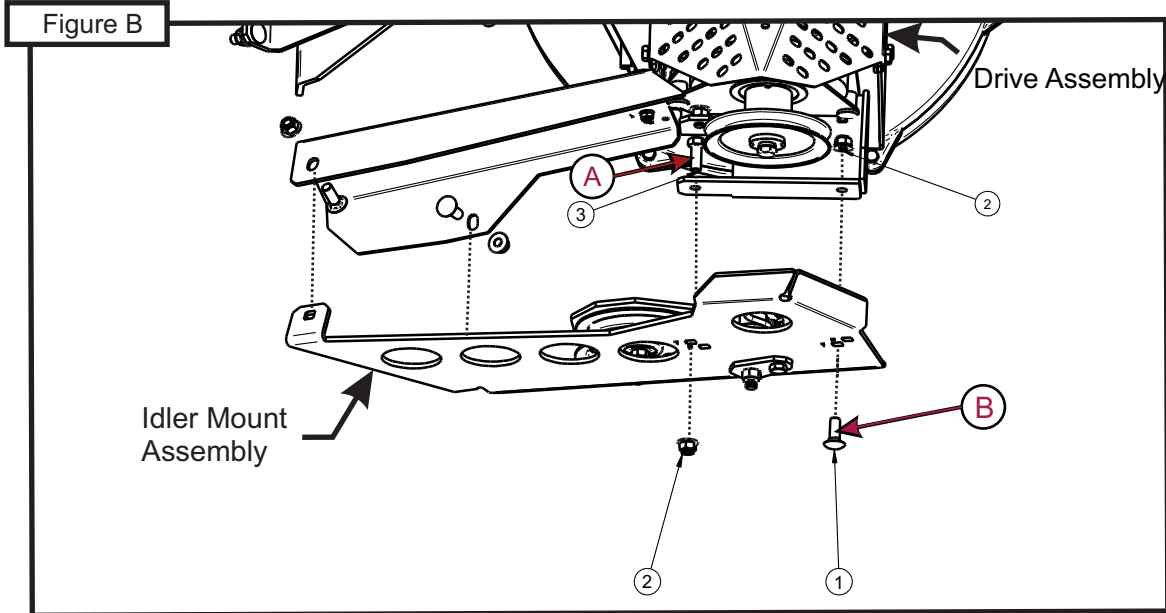

Item #	Part #	Desc.	Qty.
1	K1182	Carriage Bolt 3/8"-16 x 1"	1
2	K2038	Ny-Flange Lock Nut 3/8"-16	2
3	K1191	HHCS 3/8"-16 x 1" GR5	1

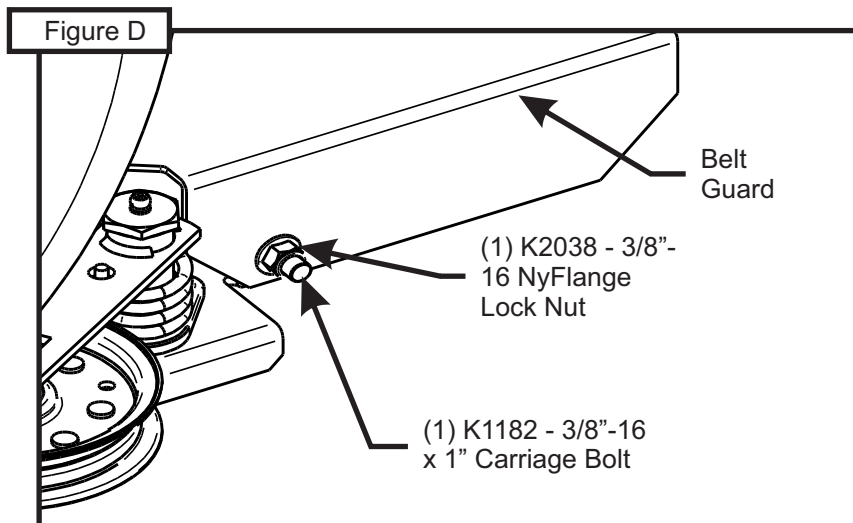
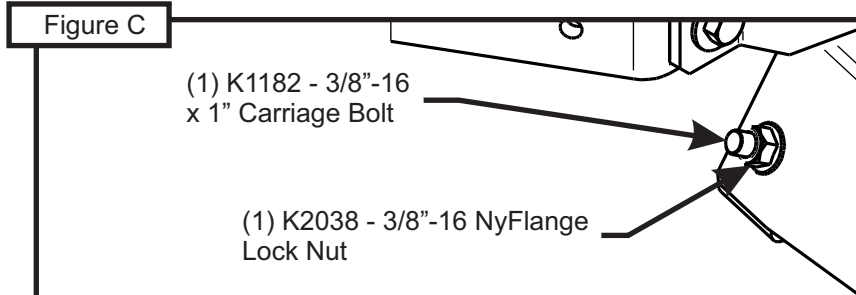

Drive Assembly and Belt Installation

(Note: It is recommended that someone assist during this step.)

Insert the Drive Assembly into the receiver tube on the Mount Arm Assembly until the Knob Plunger Pin engages. Once in place, turn Lock Handle clockwise until tight. Next, feed the AK80 Belt P#(M0322) between the Belt Guard and the Idler Mount Assembly. Place belt around the Engine Drive Pulley on the underside of the mower. While one person inserts a screw driver (or similar tool) into the Idler Mount Assembly and rotates lever arm clockwise, enough to relieve all tension from belt, place belt around the Drive Assembly Pulley. Once the belt is in position, carefully release the tension to tighten belt.

Refer to the images below.

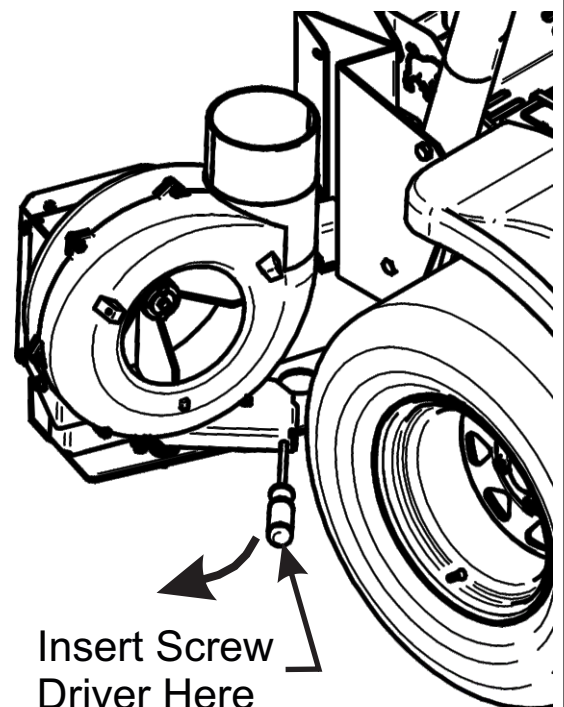
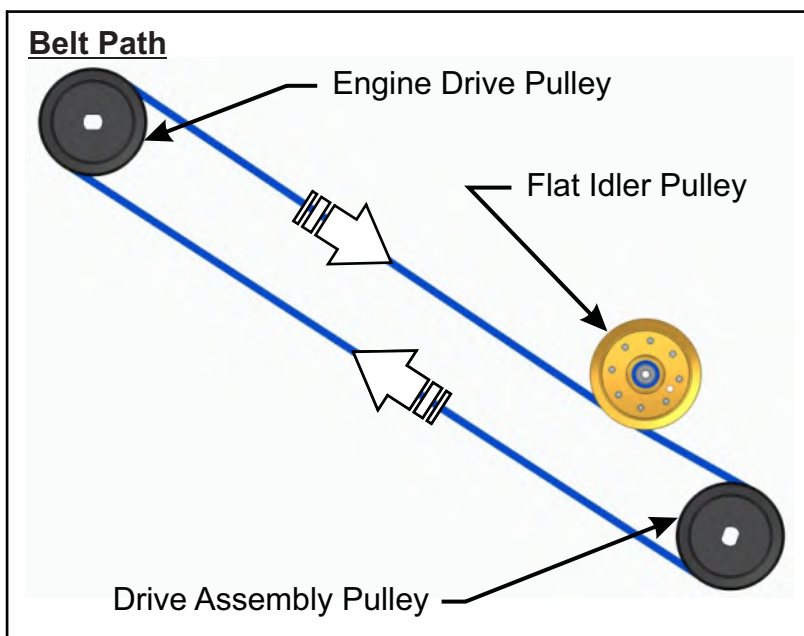
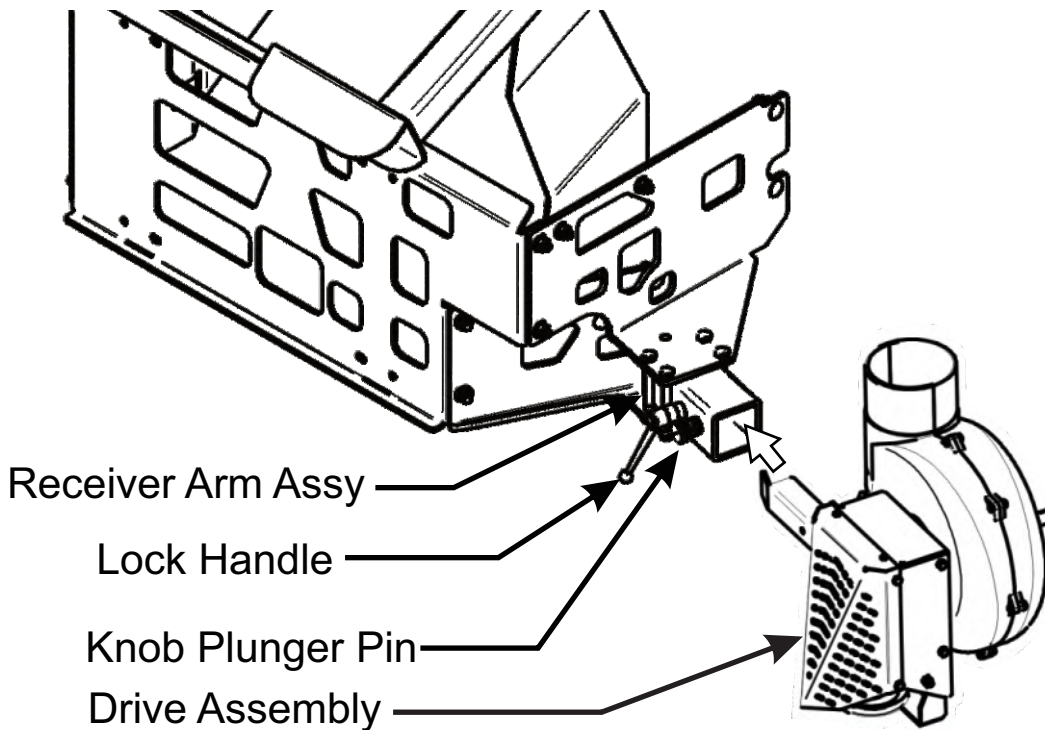

Lift Handle Installation

NOTE: Before continuing the Lift Handle installation, have someone assist you in turning the Box Assembly upside down. Insert (1) 3/8"-16 x 2" HHCS P#(K1208) into the Lift Handle P#(A0897), and secure with (1) 3/8"-16 Flange Nut P#(K1215). Thread the flange nut onto the bolt upside down, as shown in Figure A. Do not tighten the nut fully at this time.

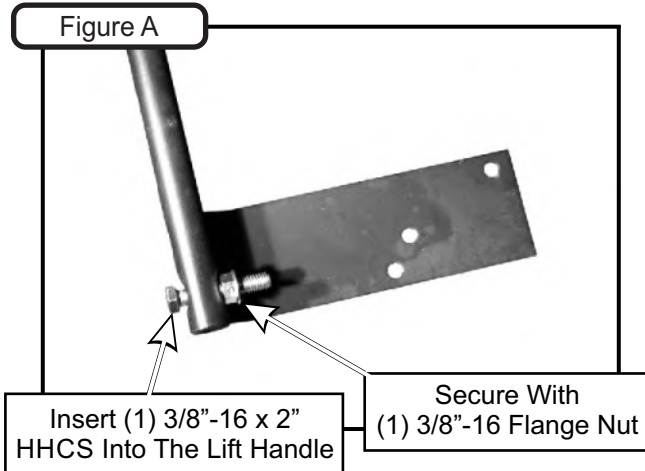

Slide the Lift Handle through the slot on the Handle Mount Bracket. Insert the Lift Handle into the Box Frame as shown in Figure B, and secure using (1) 3/8"-16 Flange Nut P#(K1215) on the inside of the Box as shown in Figure C. Now test the movement of the handle. It should have full-range of movement in the slot. If the handle does not have full-range of movement, adjust the 3/8"-16 Flange Nut from step A. Once achieved, tighten the fasteners.

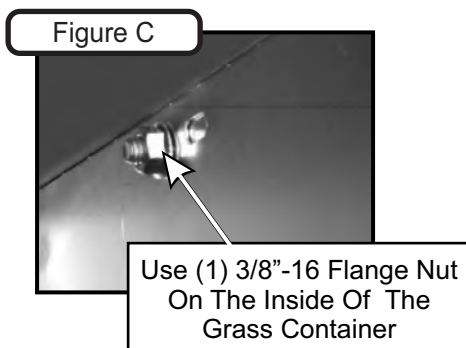
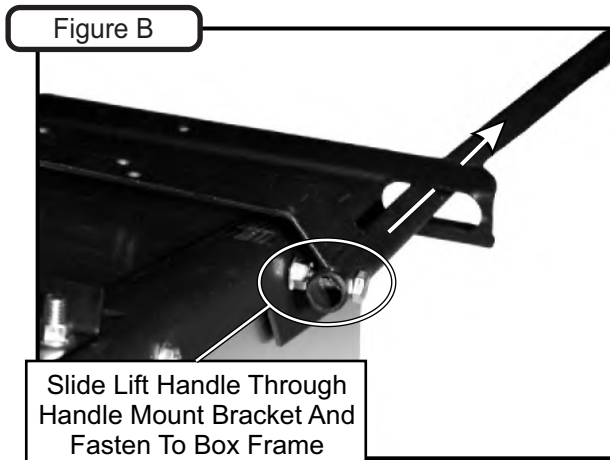

Fasten the Ball Joint P#(K1442) to the end of the Latch Rod P#(A2107). Tighten the Ball Joint to approximately half-way down the threads on the Latch Rod. Attach the Ball Joint to the Latch Hook as shown in Figure D, using (1) 5/16"-24 Hex Nut P#(K1444) and (1) 5/16" Lock Washer P#(K0043).

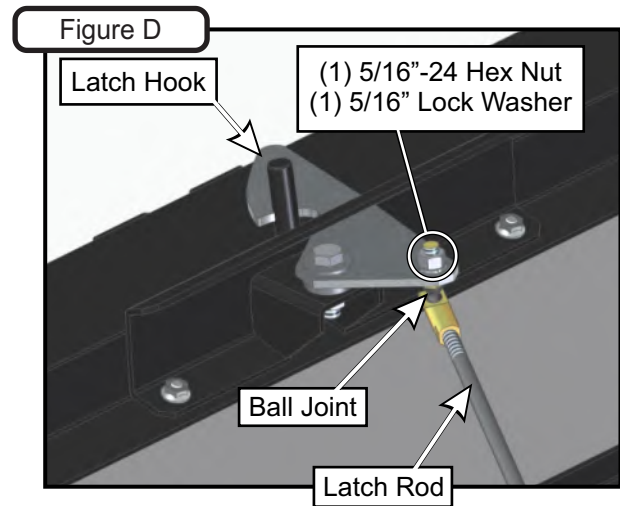

Attach the other end of the Latch Rod to the Lift Handle, as shown in Figure E. Attach one end of the Spring P#(J0176) to the Lift Handle and the other end of the Spring to the Handle Mount Bracket as shown in Figure F. Adjust the Ball Joint up or down on the Latch Rod threads until the Latch Hook closes completely. After adjusting the Latch Hook, secure the Latch Rod to the Lift Handle using (1) Cotter Pin P#(K0094).

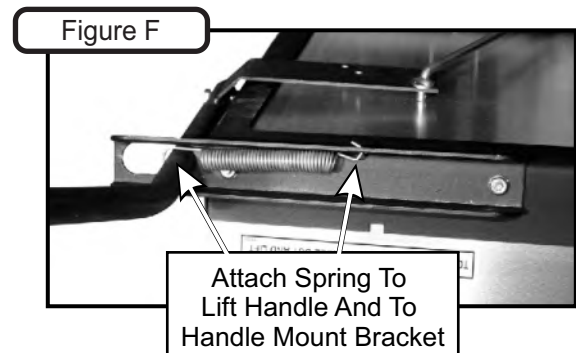
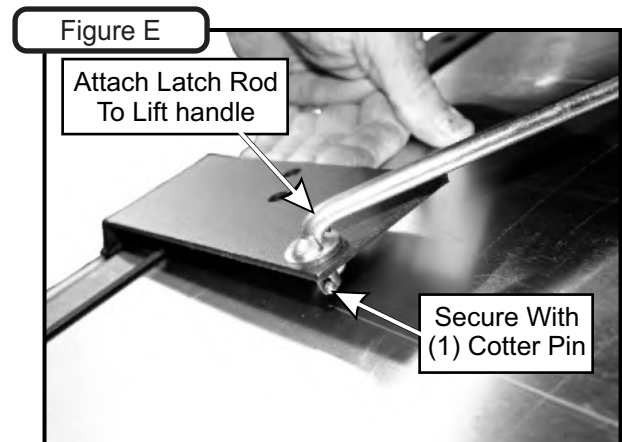

Aluminum Box Assembly Installation

NOTE: It is recommended that two extra people assist in mounting the Box Assembly. Two can lower the Box onto the frame while the third person inserts the Pivot Pins P#(K0172) through the holes. Insert the Pins from the outside to the inside. Secure with (1) 5/8" Washer P#(K0058) and (1) 5/32" x 2-5/8" Hair Pin Clip P#(K0088) per Pivot Pin (Figure B). Reattach the bottom ends of the door opening linkages to the Main Frame by using (1) Rue-Ring Cotter Pin P#(K1437) per side. To test the functionality of the dump mechanism, pull the Lift Handle away from the unit, and lift upward. The Door of the Box Assembly should open and the Box should pivot clockwise towards the ground.

Figure B

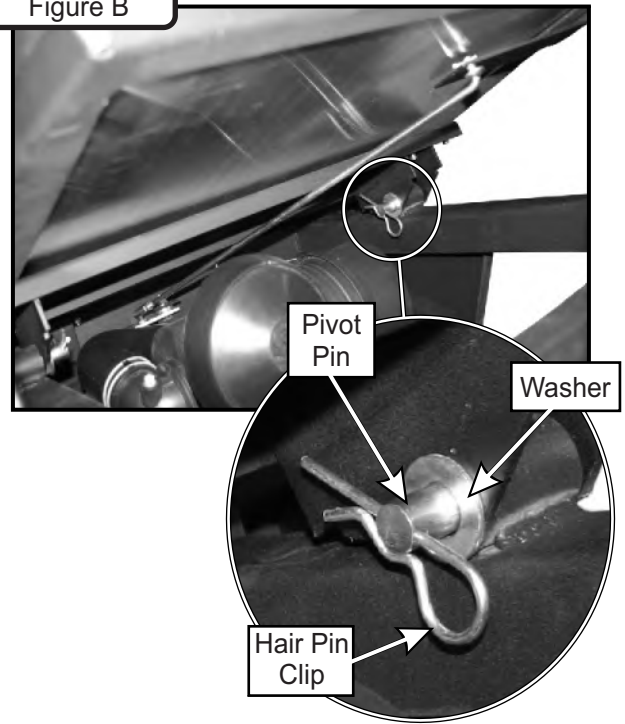
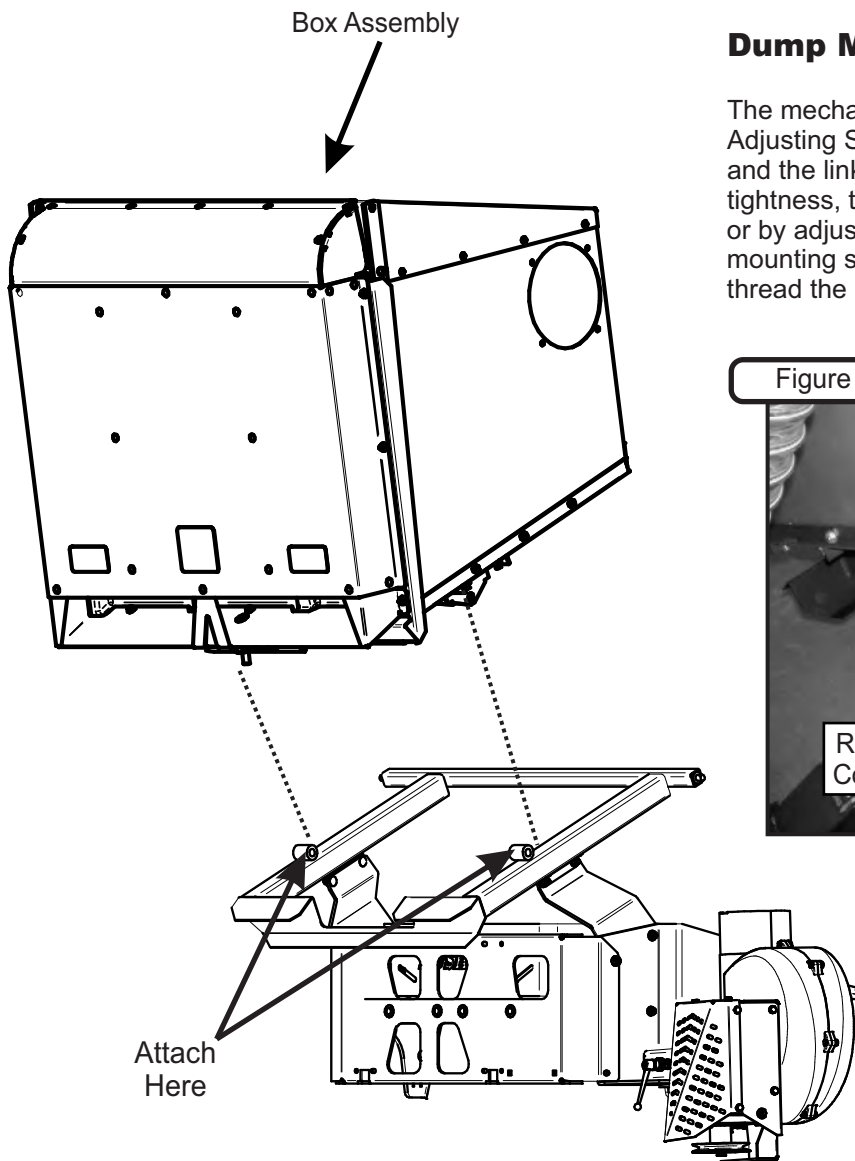

Figure A



Dump Mechanism Adjustment

The mechanism may be adjusted in three places, at the Adjusting Screw P#(K1435), at the Latch Hook Pivot Bolt and the linkage Ball Joint. To change the door closure tightness, thread the Adjusting Screw (Figure C) in or out or by adjusting the Latch Hook Pivot Bolt within its' mounting slot. To adjust the Latch Hook closure angle, thread the Linkage Ball Joint in or out.

Figure C

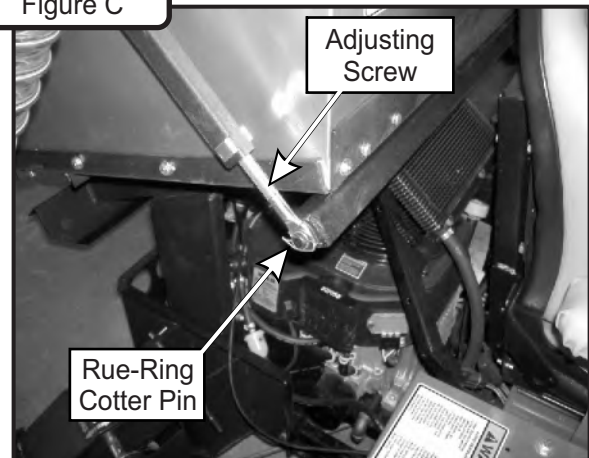

Inlet, Inlet Ring & Debris Deflector Installation

Open box door. From inside box, slide Inlet (Item #3) halfway into inlet hole (See Figure A). Take each half of the Inlet Ring (Item #1) and attach around matching groove in Inlet (Item #3). Slide Inlet (Item #3) & Inlet Ring (Item #1) against inlet hole and align four holes. Fasten Inlet Ring (Item #1) bottom holes using (2) 5/16" IT Tooth Lock Washers (Item #4) & (2) 5/16"-18 x 1/2" HHCS (Item #6) (See Figure B). Fasten Inlet Ring (Item #1) top holes using (2) 5/16" IT Tooth Lock Washers (Item #4) & (2) 5/16"-18 x 1-1/4" HHCS (Item #5). Slide Debris Deflector (Item #2) over inside top bolt threads (Item #5). Fasten Debris Deflector (Item #2) using (2) 5/16"-18 Ny-Flange Lock Nuts (Item #7). Final assembly should resemble Figure C.

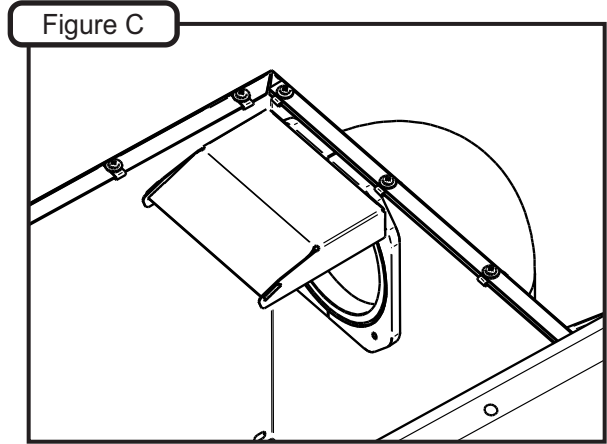
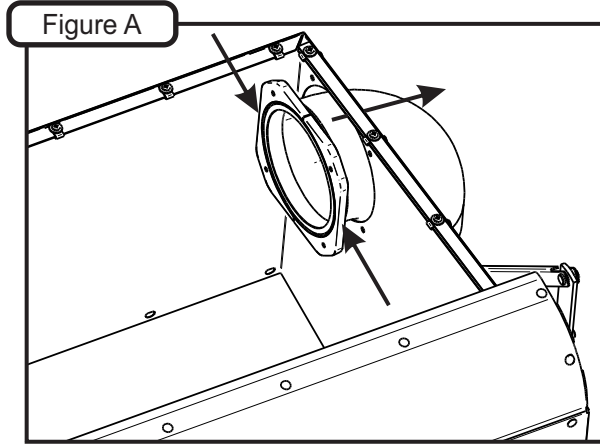
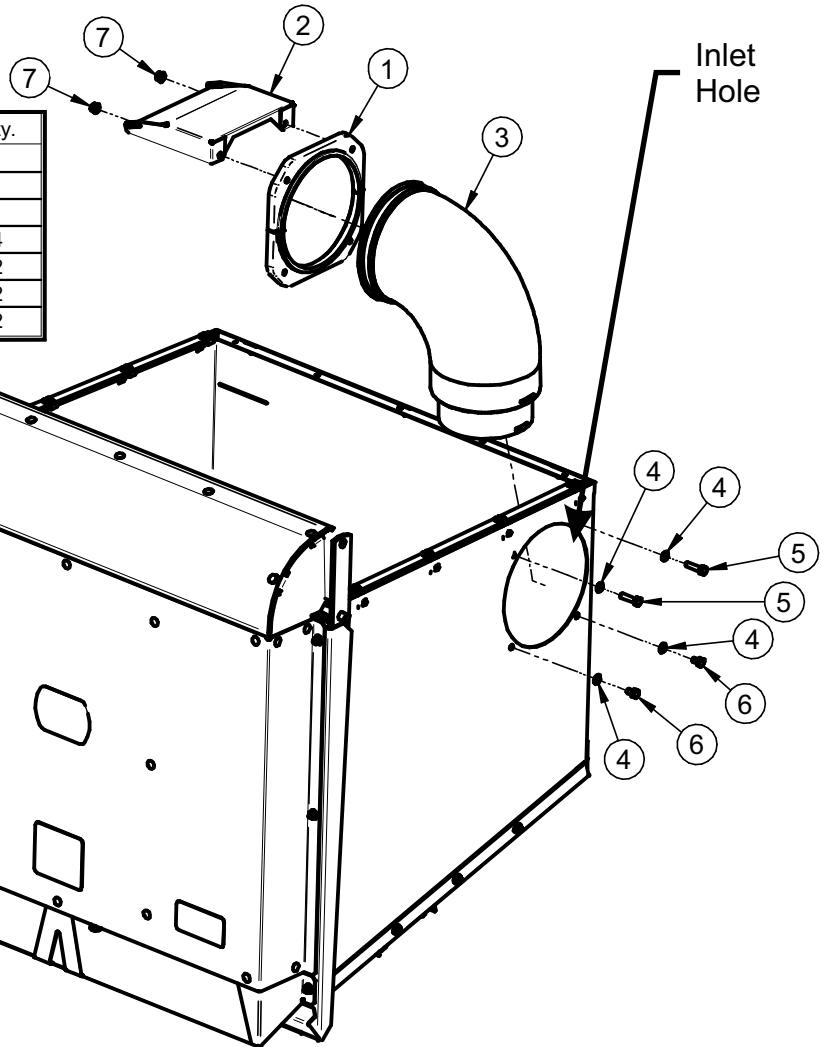

Figure B

Item #	Part #	Desc.	Qty.
1	C0074	Inlet Ring	1
2	C0088	Debris Deflector	1
3	V0025	Universal Inlet / 6" & 7"	1
4	K0044	I/T Tooth Lock Washer 5/16"	4
5	K1156	5/16"-18 x 1-1/4" HHCS	2
6	K1152	HHCS 5/16"-18 x 1/2"	2
7	K2516	Ny-Flange Lock Nut 5/16"-18	2



Open Box Door
To Assemble Inlet,
Inlet Ring & Debris
Deflector

Note: Box Top & Screen Removed
In Figure Above For Visual Clarity.

Blower Cone Installation

Thread (1) 5/16"-18 Jam Nut P#(K0120) onto each end of (2) 5/16"-18 x 2-1/2" HHCS P#(K0125) as shown in Figure A.

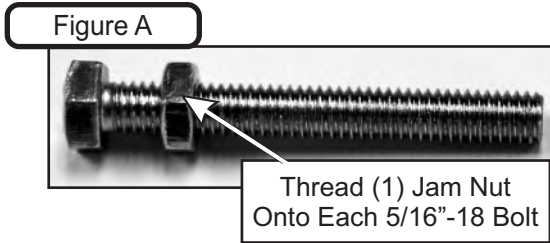

Now partially thread (1) bolt into each of the two threaded bosses located on the Blower Housing. Place 8" Blower Cone P#(E6009) so the two tabs line up with the bolts and tighten completely as shown in Figure B.

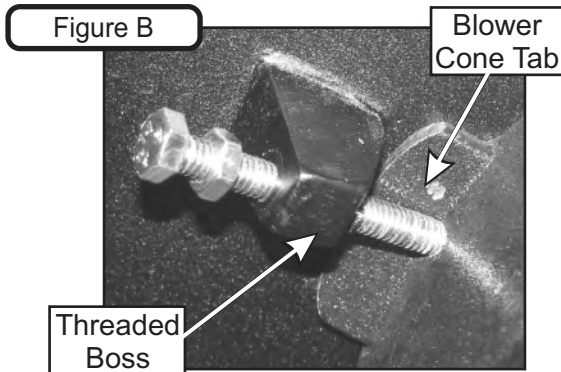

Once the (2) bolts are tight, tighten the Jam Nuts against the threaded boss as shown in Figure C.

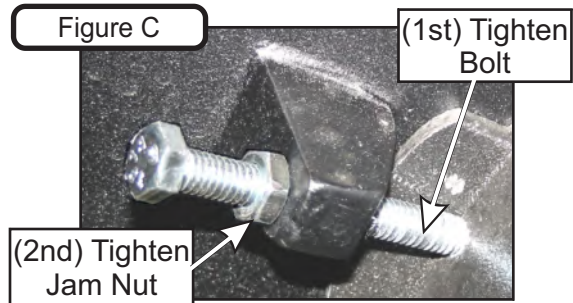

Refer to Figure D for proper Blower Cone installation reference.

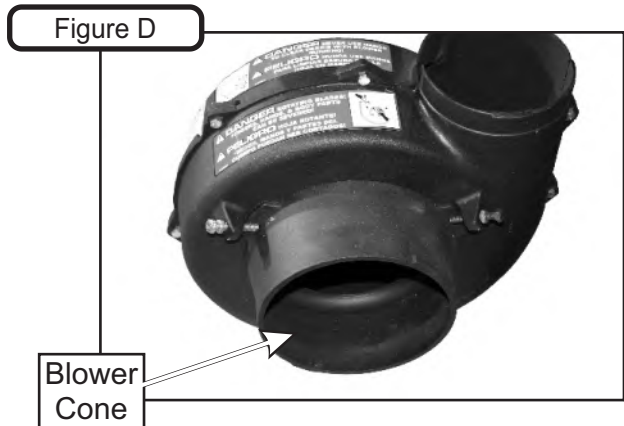

Boot Kit Installation

The Boot Plate has designated slots based on the mower's deck size. If your mower has a 52" deck size, use the slots designated with a "5". If your mower has a 61" deck size, use the slots designated with a "6". Refer to Figure A.

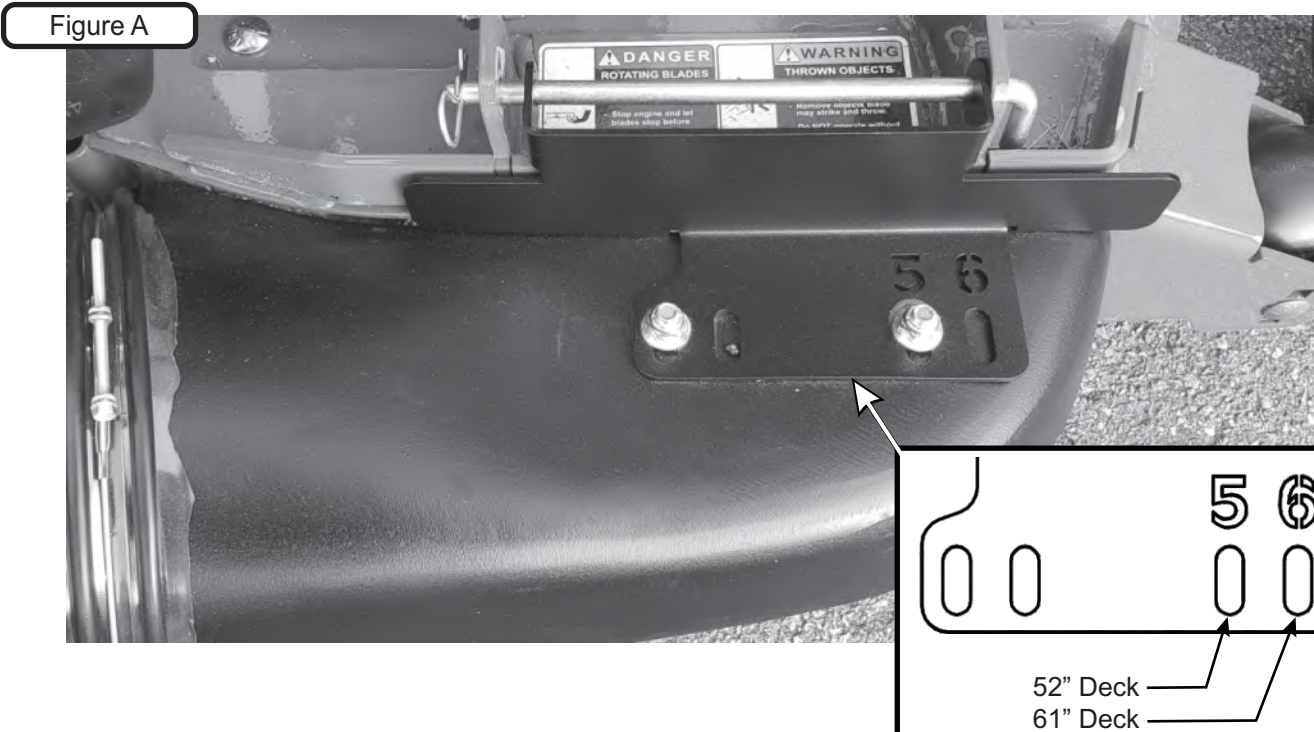

Boot Kit Installation (Continued)

First, loosely secure the Boot Plate (Item #2) to the Aluminum Boot (Item #1) using (2) 3/8"-16 x 1" Carriage Bolts (Item #3) and (2) 3/8"-16 Ny-Flange Lock Nuts (Item #4). Insert the Carriage Bolts from the inside of the Boot so the threads are on the top of the Boot. This will prevent grass clippings from collecting on the threads. Refer to Figure B.

Figure B

Item #	Part #	Desc.	Qty.
1	E1030	BOOT	1
2	B1062	Boot Plate	1
3	K1182	Carriage Bolt 3/8"-16 x 1"	2
4	K2038	Ny-Flange Lock Nut 3/8"-16	2
5	B0288	Boot Rod	1
6	K0099	Hair Pin Clip 3/32"	1

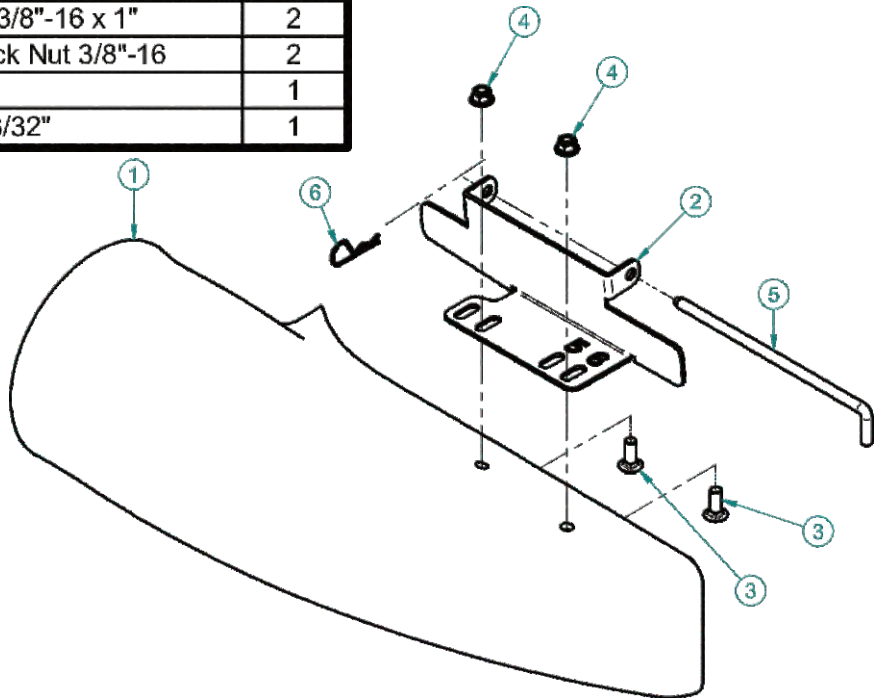

Next, position the Boot Plate to the deck edge rotated at 45° (#1) (refer to Figure C) aligning the Boot Plate to the deck's discharge chute mount bracket (#2). Secure the Boot Plate (#3) to the mower's discharge chute mount bracket by using (1) Boot Rod (Item #3) and (1) Hair Pin Clip (Item #4). Refer to Figure C.

With the Carriage Bolts still loose, adjust the position of the boot so that there is no gap between the mower's discharge edge and the Boot. Once the boot is correctly positioned, tighten all hardware.

Figure C

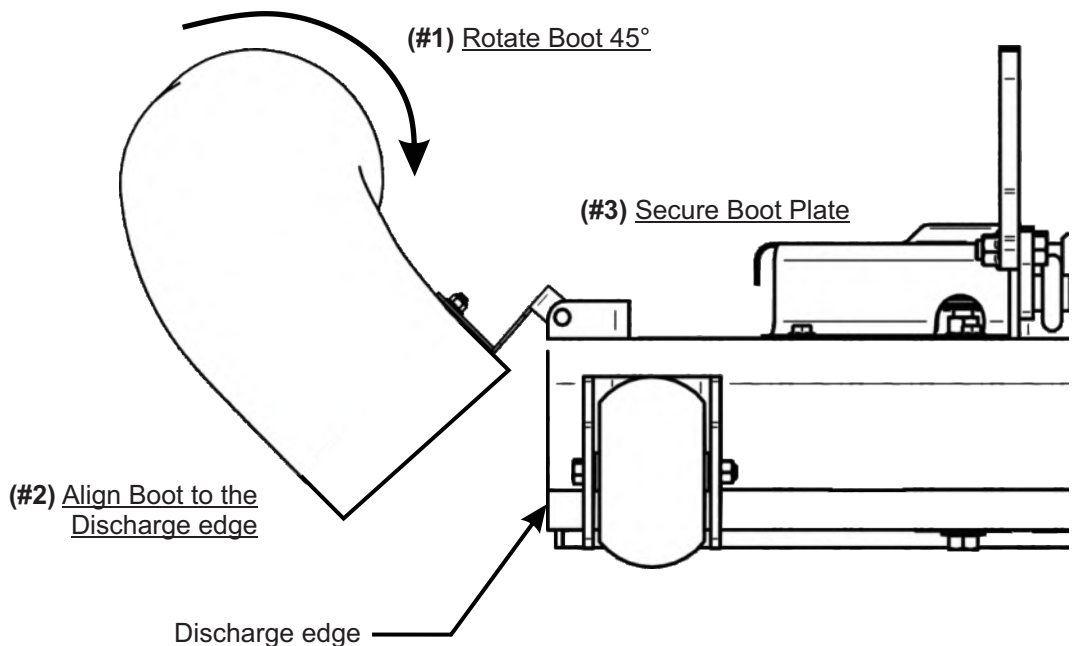

Length Of Hose Adjustment

The hoses in the following steps must be cut to fit your machine. Do not cut the hoses until you have tried to fit them on your machine. Remember that the hoses need to be long enough to allow for the opening and closing of the collection system as well as allowing ample clamping surface between each component.

Upper Hose Installation

Slide a Hose Clamp P#(J0060) over one end of the 6" Upper Hose. Secure this end of the 6" Upper Hose to the Blower Outlet. See Figure below for details. Secure opposite end of the 6" Upper Hose to the Inlet. Make sure both ends are securely fastened by tightening the Hose Clamp and rotating the Inlet Snap Fastener towards the hose to lock in place.

Lower Hose To Blower Cone Installation

Slide a Hose Clamp P#(J0080) over both ends of the Lower Hose. Secure one end of the Lower Hose to the Blower Cone and fasten by tightening the Hose Clamp.

Lower Hose To Boot Installation

Take the unattached end of the Lower Hose and secure it to the circular end of the Boot and fasten by tightening the Hose Clamp.

Tip: Before securing Hose Clamp fully, rotate Lower Hose counter-clockwise (away from yourself) approximately 1" to aid in retaining Boot to mower deck.

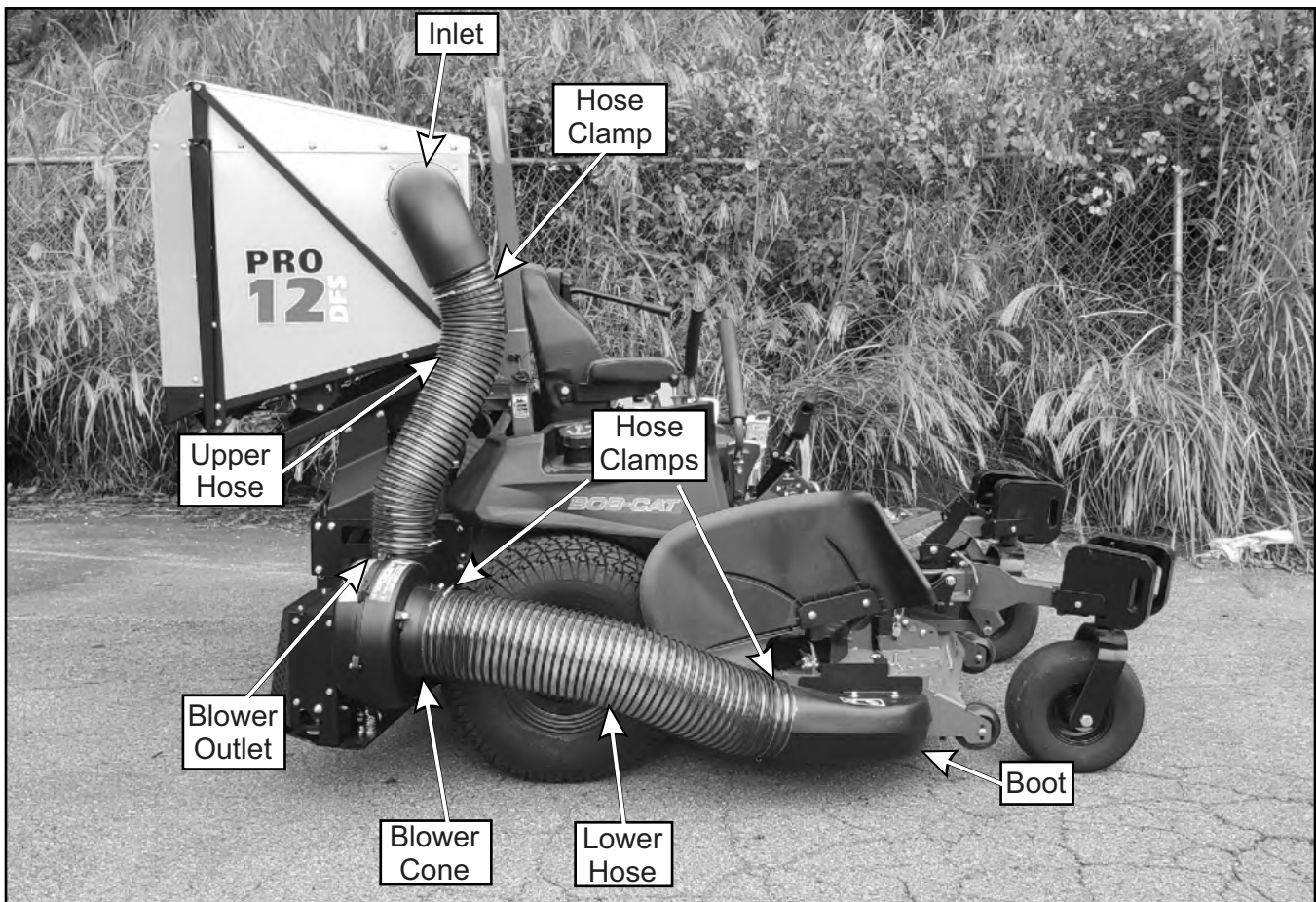

Wire Harness Installation



WARNING

**To Prevent Serious Injury-
Proper Installation Of Safety Interlock Harness
Is Mandatory. Please Check That All Interlock
Points Work Correctly Once Installed.**

Route the Wiring Harnesses' Female Quick Connector around the engine, between the ROPS and the engine through the opening in the rear bumper. Connect the Quick Connector to the Male Quick Connect Plug (#1) located on the PTO Drive. Refer to Figure A.

Disconnect the mower's clutch from the mower's harness and connect the Wiring Harnesses' Engine Connector (#2) to the clutch wiring and to the mower's harness.

Route the Positive Lead w/ Fuse Block to the positive terminal of the battery (#3) using the Ring Terminal of the Positive Lead to secure the attachment. Route the Negative Lead to the Negative Terminal of the mower's battery (#4) using the Ring Terminal of the Negative Lead to secure the attachment. Refer to Figure A.

Refer to the next page for the installation of the PTO Engagement Rocker Switch (P#P0293).

Refer to Figure D on page 24 for the wire diagram.

Figure A



(#1) Wire Harness Quick Connector

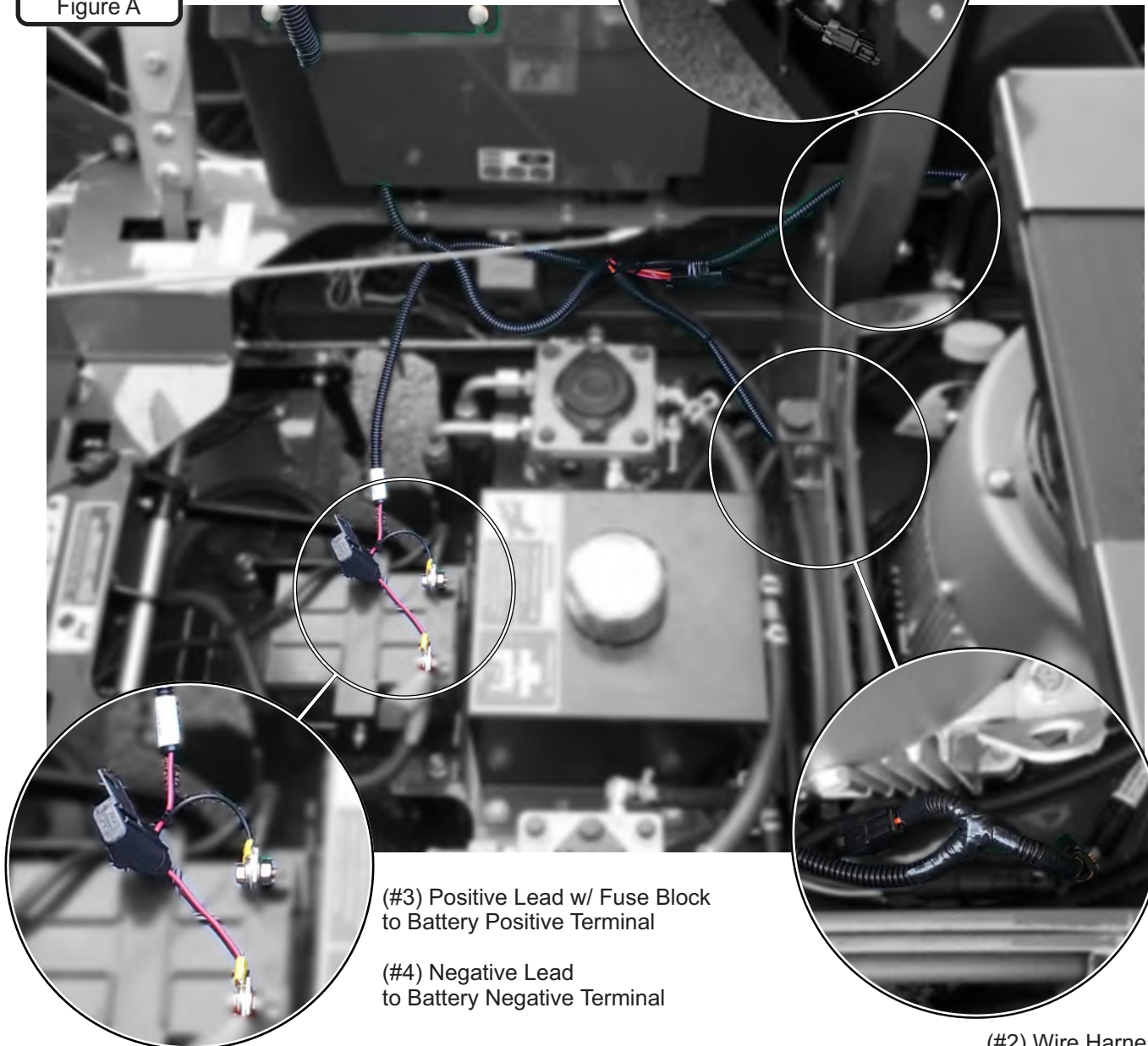

(#3) Positive Lead w/ Fuse Block to Battery Positive Terminal

(#4) Negative Lead to Battery Negative Terminal

(#2) Wire Harness Engine Connector

Wire Harness Installation (Continued)

Loosen the (2) bolts located on the mower's side panel below the mower's controls. Align and position the Switch Mount Bracket's P#(B1955) slots behind the (2) bolts. Tighten the (2) bolts to secure Switch Mount Bracket. Refer to Figure B.

Place the PTO Engagement Rocker Switch P#(P0293) into the Switch Mount Bracket. Route the Wiring Harness' (2) Switch Connectors up through the bottom of the side panel and connect them to the PTO Engagement Rocker Switch. To protect the Switch Connectors, wrap the 4.6" Poly Loom P#(P0297) around the Switch Connectors and secure using (2) Zip Ties P#(J0245). Refer to Figure B.

Figure B



Use the Zip Ties (P#J0245) that are provided to secure the Wiring Harness in place. Refer to Figure C for the recommended zip tie points.

Figure C

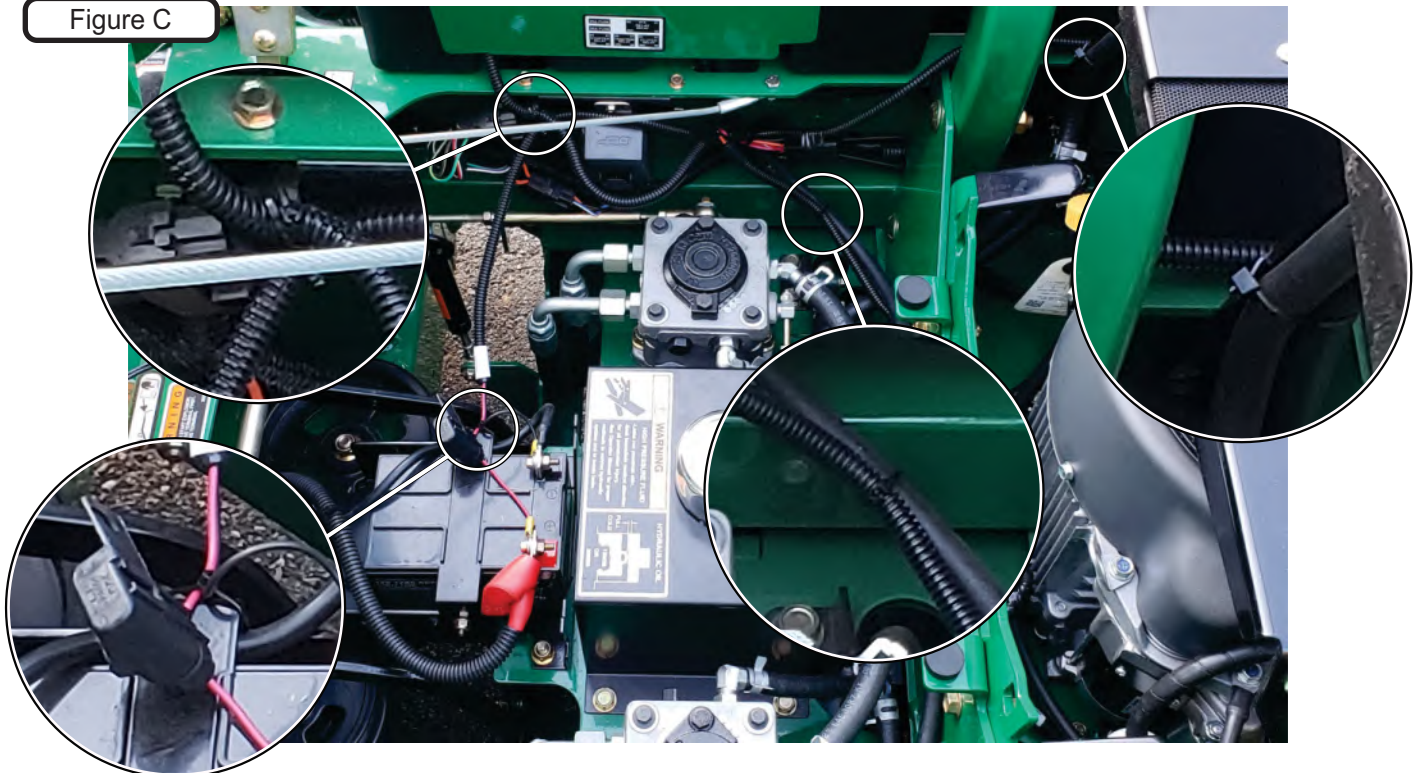

Wire Harness Installation (Continued)

Figure D

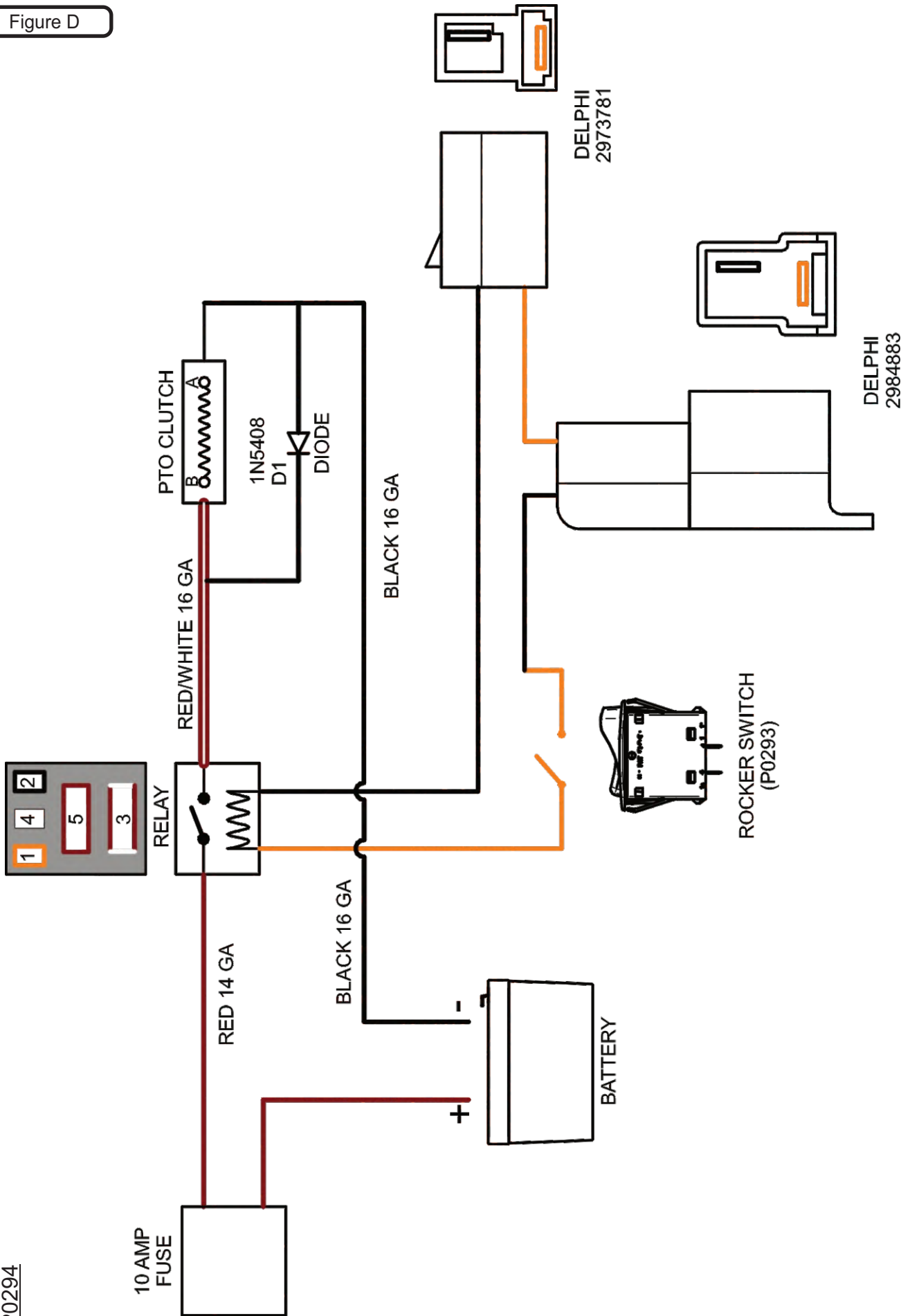

WIRE HARNESS
P0294

Impeller Blade Removal/Replacement

To Remove: First remove the 5/16"-24 x 1" HHCS P#(K0428) (#1), Taper Lock Bushing Washer P#(K0284) (#3), (2) 5/16 Flat Wahers P#(K0042) and Spacer Bushing P#(S0159) (#4) from the Taper-Lock Bushing P#(S0157) (#5). Next remove the (2) 1/4"-20 x 1" HHCS (#2) and place them into the threaded holes of the Taper-Lock Bushing (#5). Gradually thread each bolt evenly into the Taper-Lock Bushing, forcing the blade to break-away from the Taper-Lock Bushing. If the Impeller will not move, carefully hit the base of the Impeller, between each vein, with a hammer, then try again.

To Replace: Place Impeller Blade over the engine shaft. Slide the Taper-Lock Bushing (#5) on to the engine shaft and into the Impeller Blade, aligning the **non-threaded** holes of the Taper-Lock Bushing to the threaded holes of the Impeller Blade. Fasten by using (2) 1/4"-20 x 1" HHCS (#2), (1) Spacer Bushing (#4) (1) Taper-Lock Bushing Washer (#3), and (1) 5/16"-24 x 1" HHCS (#1). Torque to the proper specifications in the torque chart on the back of this manual. Next, rotate the Impeller Blade to ensure that the blade is clear of contact on all sides of the blower housing.

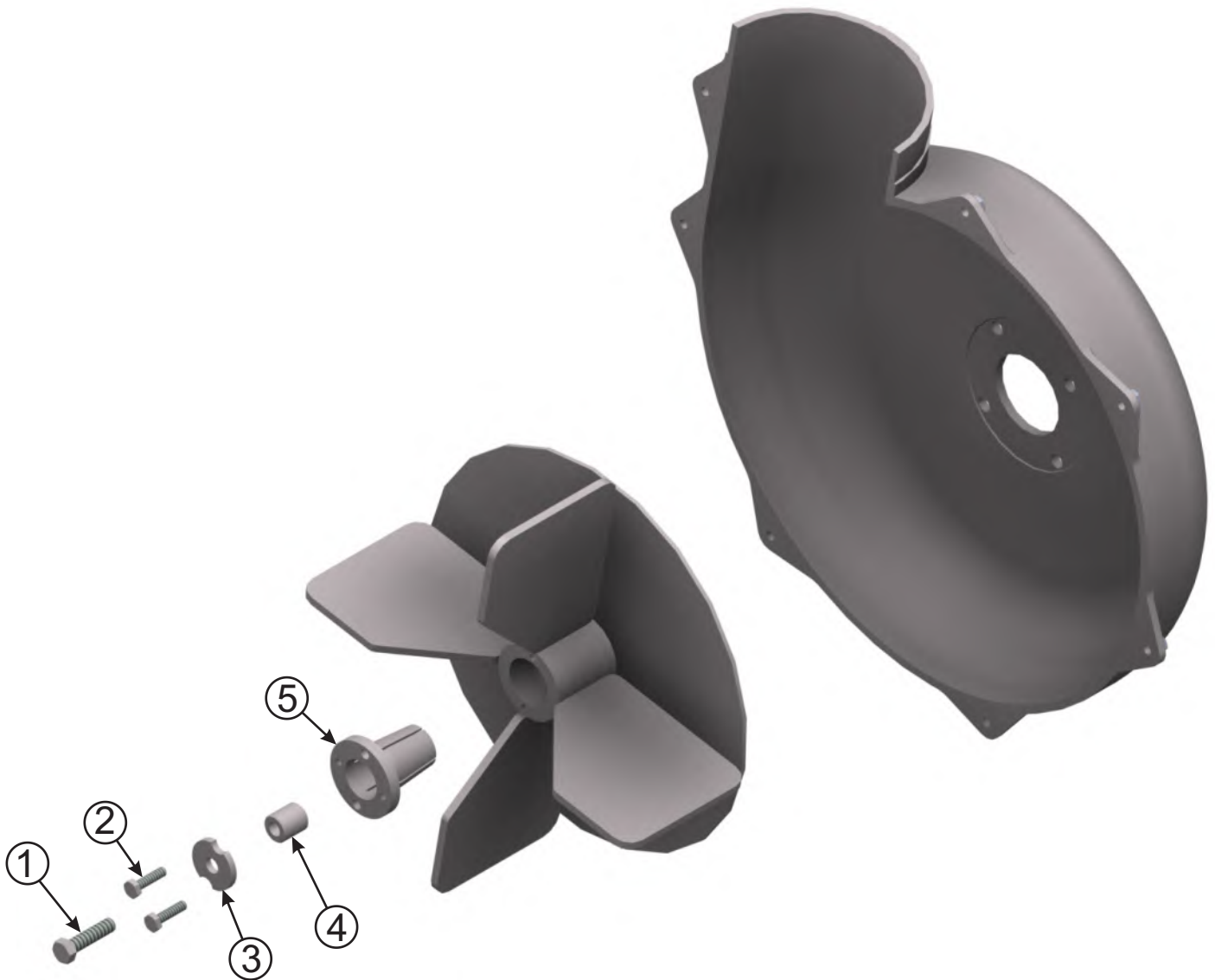

Weight Kit Installation

Position the Dual Weight Bracket Base (Item #2) under the caster tubing w/ opening towards caster fork. Next, position the Weight Bracket Clamp (Item #3) on top of caster tubing w/ opening towards caster fork.

Align the (4) holes of the Weight Bracket Clamp (Item #3) to the holes in the Dual Weight Bracket Base (Item #2). Loosely fasten the Weight Bracket Clamp (Item #3) to the Weight Bracket Base (Item #2) using (4) 5/16"-18 x 3" Bolts (Item #4.1) & (4) 5/16"-18 Ny-Flange Lock Nuts (Item #4.2).

Position the Weight Bracket Base and the Weight Bracket Clamp assembly along the caster tubing to prevent interference from caster forks or any other objects. Tighten the fasteners in an 'X' pattern until assembly is firmly clamped to caster tubing. Do not over tighten, over tightening may result in the bending of the Weight Bracket Clamps (Item #3).

Insert (1) Weight (Item #1) Into the Weight Bracket Base (Item #2) & align the holes of the Weight w/ the holes of the Weight Bracket Base (Item #2). Fasten the Weight (Item #1) to the Weight Bracket Base Using (1) Clevis Pin (Item #4.3) & (1) Hair Pin Clip (Item #4.4) per weight. Repeat for additional weight. Refer to the Figure Below.

Figure A

Item #	Part #	Desc.	Qty.
1	Y0025	28 lb. Suitcase Weight	2
2	B1014	Dual Weight Bracket / Base	1
3	B1015	Weight Bracket / Clamp	1
4	HB0687	Dual Weight Kit Hardware Bag	1
4.1	K1472	HHCS 5/16"-18 x 3" GR5	4
4.2	K2516	Ny-Flange Lock Nut 5/16"-18	4
4.3	K1473	Clevis Pin 1/2" x 3"	2
4.4	K1478	Hair Pin Cotter / Double Loop	2

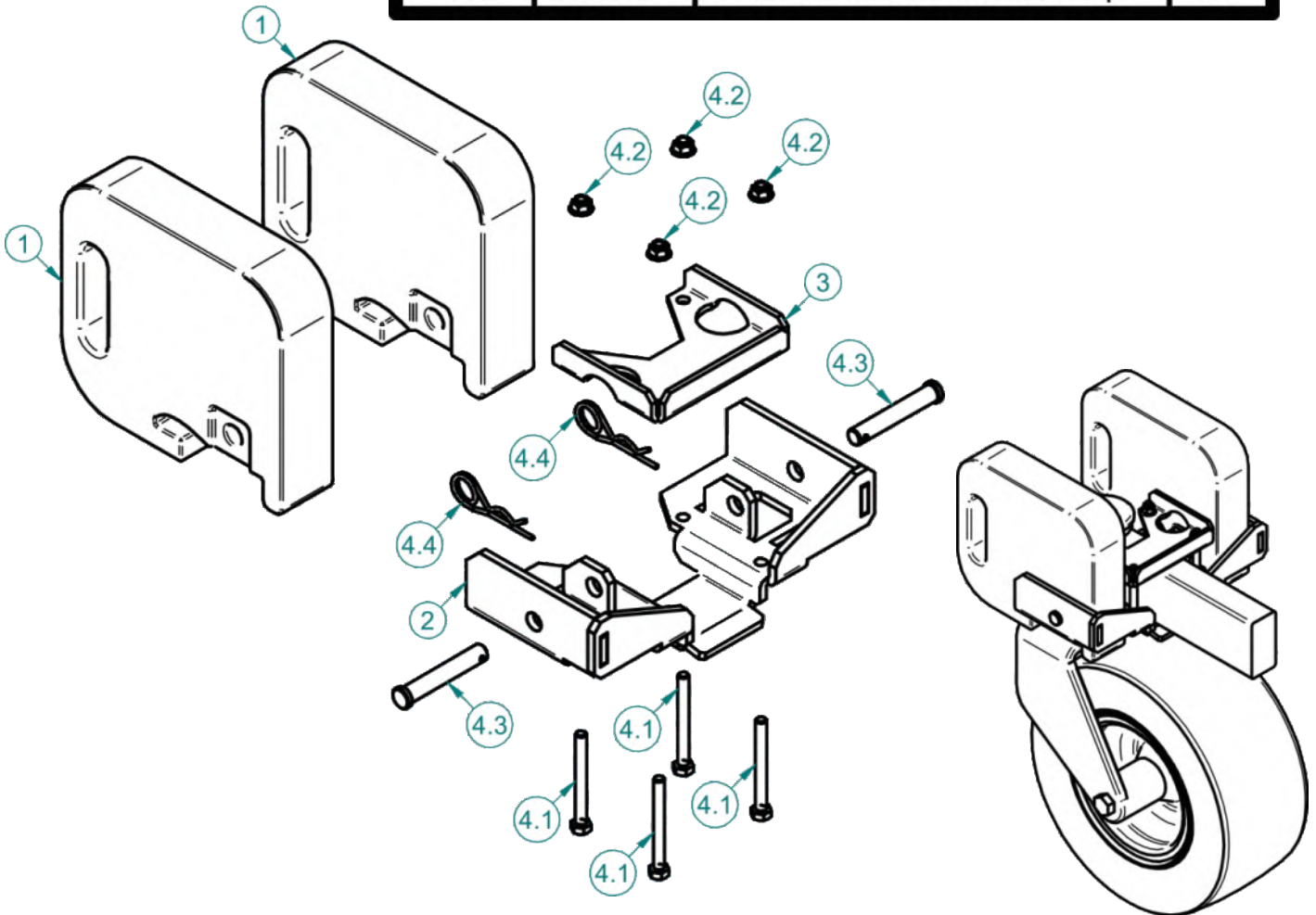

A2207 Mount Arm / Tube Assembly

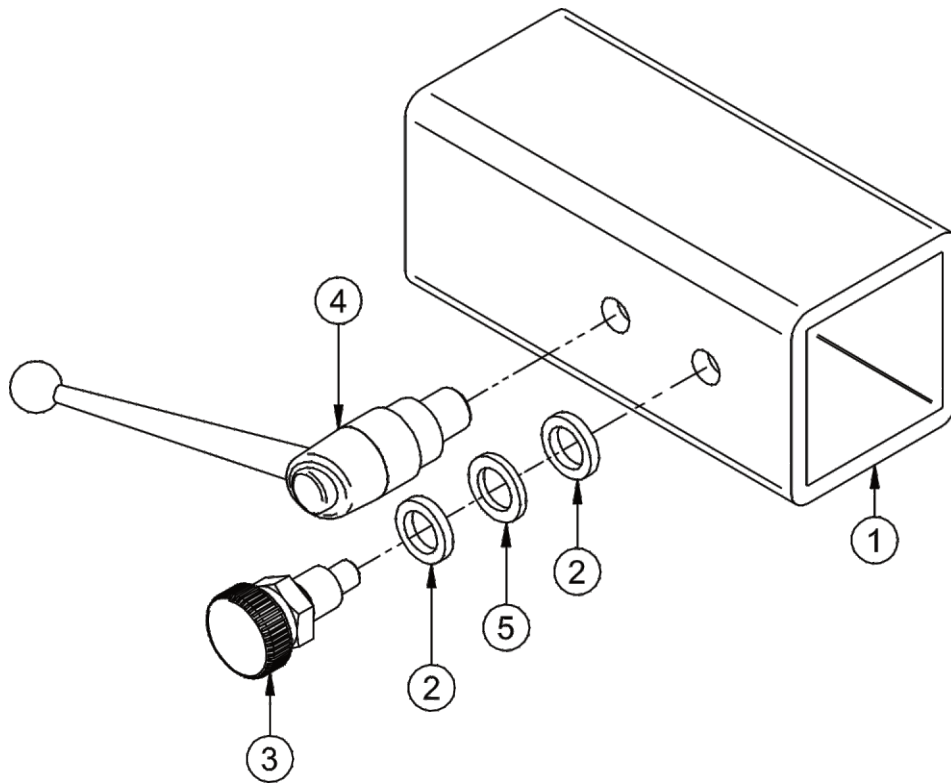

Item #	Part #	Desc.	Qty.
1	B0931	Tube / Mount Arm	1
2	J0013	Nylon Flat Washer 1/2" x .750" OD Grade 6/6	2
3	J0020	Knob Plunger Pin 1/2"-13	1
4	J0009	Adjustable Handle 1/2"-13 x .59 Male	1
5	K0027	Flat Washer 1/2" / .787 OD x .512 ID x .090 T	1

A2092 Idler Arm Assembly

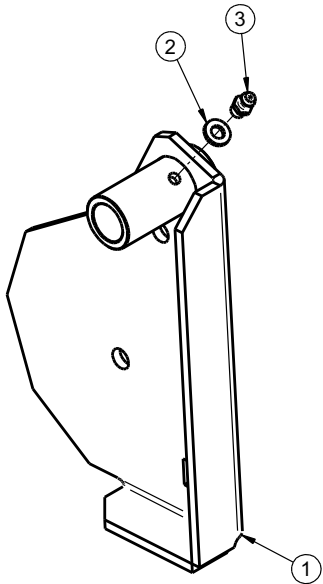

Item #	Part #	Desc.	Qty.
1	A2070_01	Idler Arm Weldment	1
2	K1467	Flat Washer M6 x 12mm OD	1
3	J0801	1/4"-28 Zirc Fitting	1

A2067_02 Idler Mount Assembly

Item #	Part #	Desc.	Qty.
1	B0958_02	Idler Mnt Pl	1
2	K2038	Ny-Flange Lock Nut 3/8"-16	2
3	K1463	Flat Washer .720 ID x 1.500 OD x .250 T	2
4	K1219	Jam Nut 3/8"-16	1
5	K1192	HHCS 3/8"-16 x 1-1/4" GR5	1
6	K0329	Nylock Nut 7/16"-14 GR8	1
7	M0003	Idler Pulley	1
8	K1462	HHCS 3/8"-16 x 1-3/4" GR8	1
9	K1464	Shoulder Bolt 7/16"-14 / Idler	1
10	J0024	Torsion Spring	1
11	A2092	Idler Arm Assy	1
12	B0974	Idler Base Plate	1

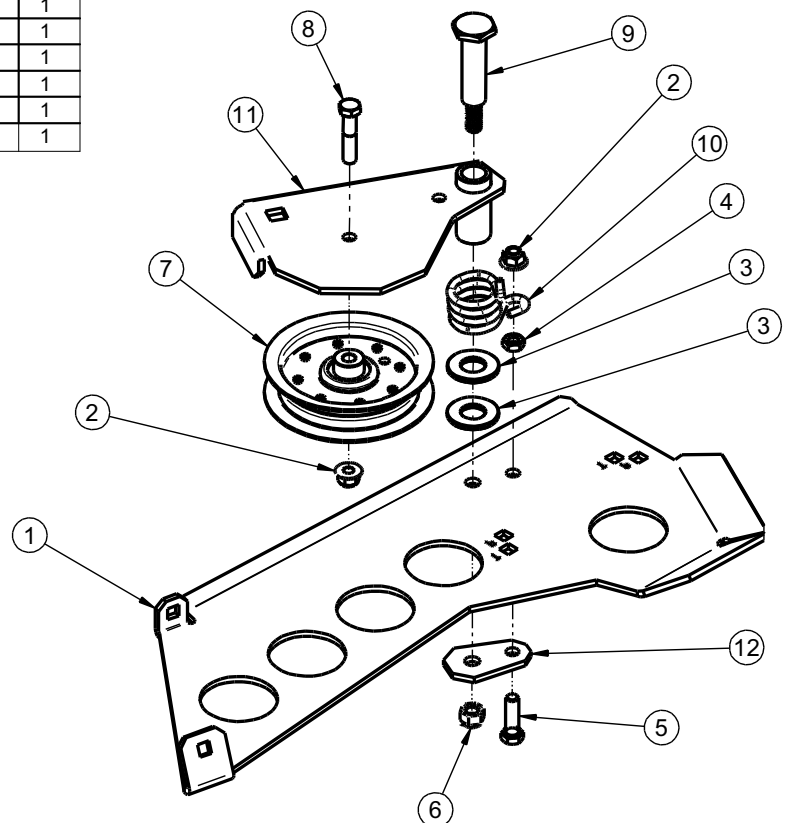

A2058 Gearbox Sub-Assembly

Item #	Part #	Desc.	Qty.
1	M0002	Gearbox	1
2	K0428	HHCS 5/16"-24 x 1" GR8	1
3	K0043	Lock Washer 5/16"	1
4	N0002	Pillow Block Bearing 7/8"	1
5	K0035	Set Screw 5/16"-18 x 1/4" Cup Point	1
6	J0272	Woodruff Key #9	1
7	A2048	Clutch Flange	1

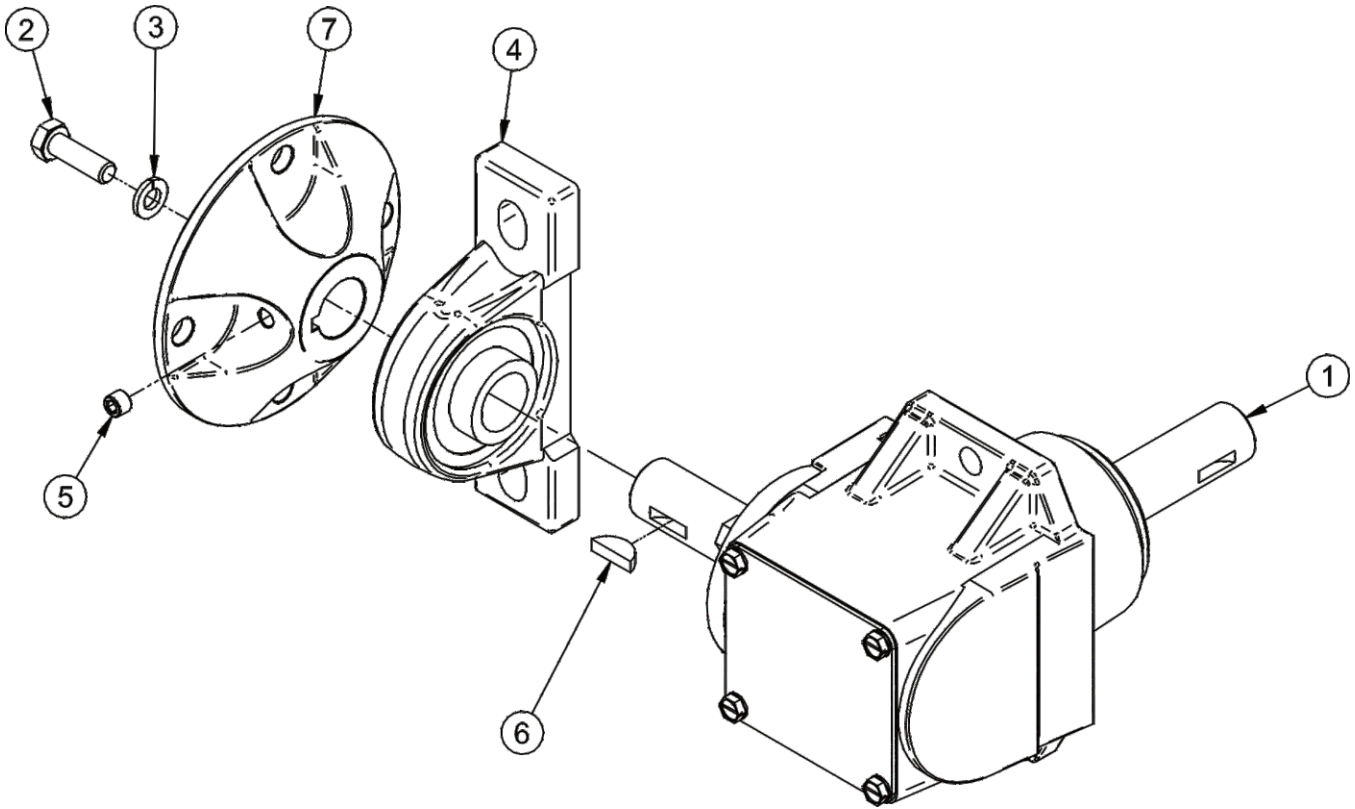

A2059_01 Clutch Sub-Assembly

Item #	Part #	Desc.	Qty.
1	M0001	Electric Clutch	1
2	S0007	Clutch Shaft	1
3	K0278	Double Indented Washer 7/16" / 1.375 OD x .440 ID x .179 T	1
4	K0140	Lock Washer 7/16" / High-Collar Helical Spring	1
5	K0359	HHCS / 7/16"-20 x 3.50" w/ Patch	1
6	M0309	A-Section Pulley / 4.75 OD (PTO-X)	1
7	S0221	Eng. Pulley Bushing #27	1
8	K0076	Key 1/4" x 3/4" Long	1

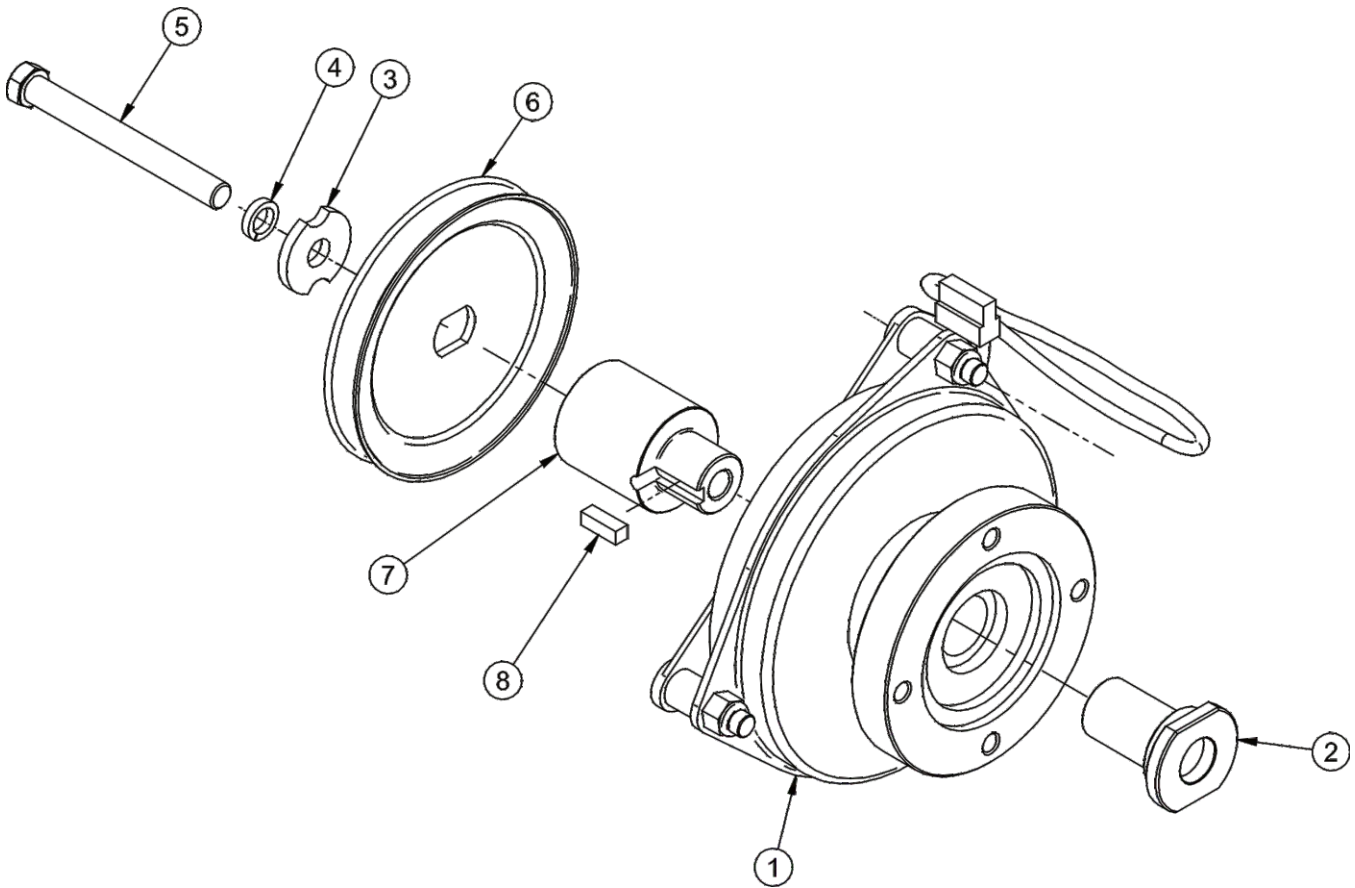

A2057_01 Drive Assembly Exploded Parts View

Item #	Part #	Desc.	Qty.
1	K0048	Lock Washer 3/8"	4
2	K0343	HHCS 3/8"-16 x 7/8" GR8	4
3	A2059_01	Clutch Sub-Assy	1
4	A2058	Gearbox Sub-Assy	1

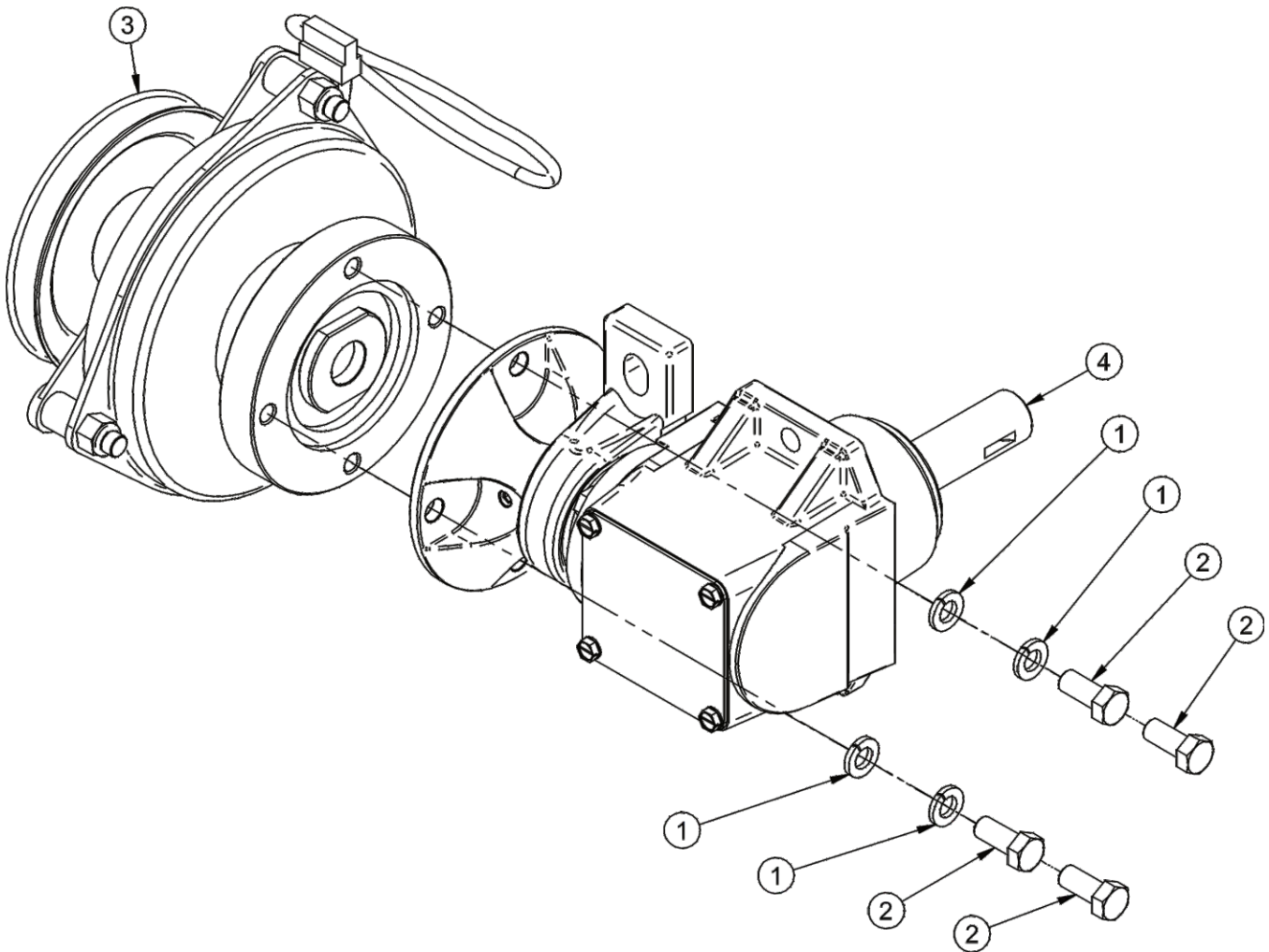

A2060_01 Mounted Drive Assembly

Item #	Part #	Desc.	Qty.
1	B0940	Spacer Plate	1
2	A2034	Drive Mnt Assy	1
3	K0309	3/8"-16 x 1-1/4" SHCS	2
4	K0048	Lock Washer 3/8"	2
5	K0055	Flat Washer 1/2" / 1.383 OD x .560 ID x .120 T	2
6	K0056	Lock Washer 1/2"	2
7	K1234	HHCS 1/2"-13 x 2"	2
8	A2057_01	Drive Assy	1

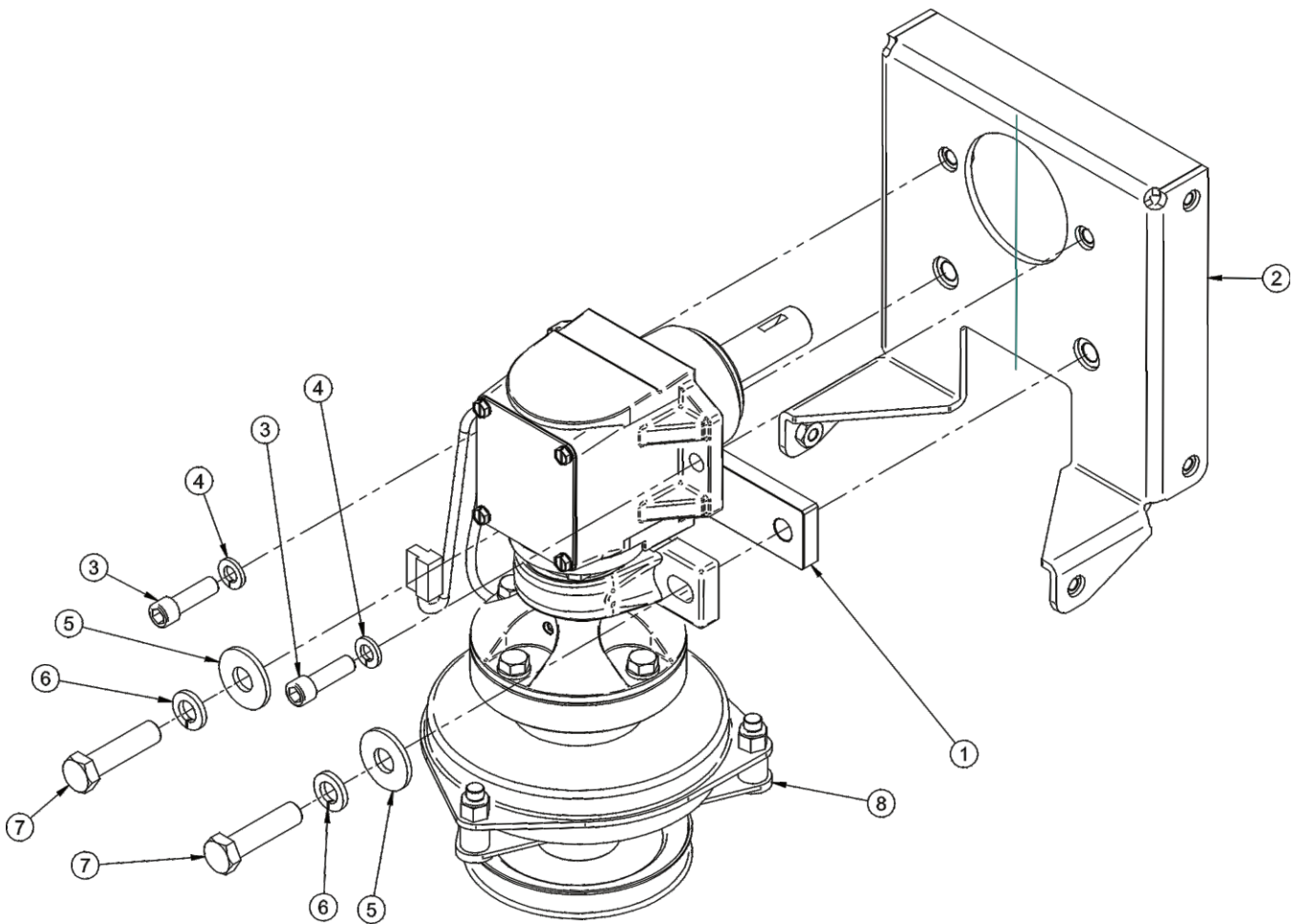

A2039_01 Base Drive Assembly

Item #	Part #	Desc.	Qty.
1	B0938_01	Drive Guard	1
2	A2032	Drive Arm Assy	1
3	A2035_02	Housing Mnt Assy	1
4	B0942_02	Anti-Rotation Brkt	1
5	K1153	HHCS 5/16"-18 x 3/4"	4
6	K0043	Lock Washer 5/16"	8
7	K0353	HWHTCS 1/4"-20 x 1/2"	2
8	K1154	HHCS 5/16"-18 x 1"	4
9	K2516	Ny-Flange Lock Nut 5/16"-18	4
10	A2060_01	Mounted Drive Assy	1
11	P0271	Quick Connect Wire Harness	1
12	K1142	5/16"-18 x 3/4" Carriage Bolt	4
13	K0343	HHCS 3/8"-16 x 7/8" GR8	1
14	K1477	Flat Washer / 3/8" / .406 ID x .812 OD x .125 Thk	1
15	K1476	Reverse Lock Nut / 3/8"-16 Grade C	1
16	B1100	Idler Assy Mount Plate	1

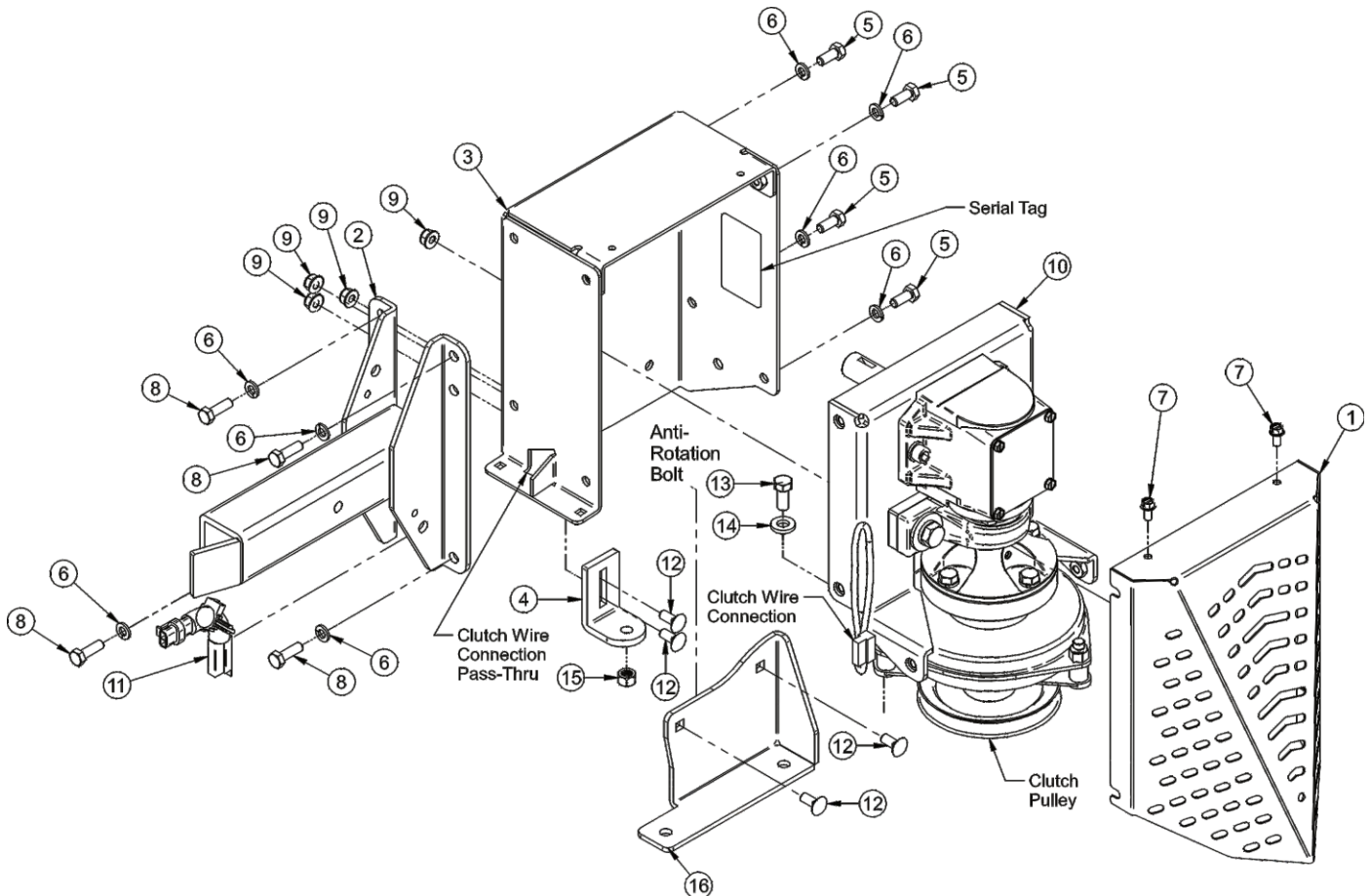

A2061_02 Drive Assembly / 4-Blade Impeller

Item #	Part #	Desc.	Qty.
1	A0645	4-Blade Impeller Weldment	1
2	K0284	Double Indented Washer 3/8" / 1.375 OD x .380 ID x .179 T	1
3	K1465	HHCS 5/16"-24 x 1-1/2" GR8	1
4	K1225	HHCS 1/4"-20 X 1" GR8	2
5	S0159	Spacer Bushing .938 OD x .325 ID x .375 T	1
6	K0044	I/T Tooth Lock Washer 5/16"	4
7	K1154	HHCS 5/16"-18 x 1"	4
8	A2039_02	Drive Assy / Base	1
9	S0157	Taperlock Bushing 7/8"	1
10	K0042	Flat Washer 5/16" / .875 OD x .380 ID x .075 T	2
11	E4052A	Blower Hsg Assy	1
11.1	E4052F	Blower Hsg Front	1
11.2	E4052B	Blower Hsg Back	1
11.3	HB0462	HW Bag / E4004A & E4052A Housings	1
11.3.1	K1401	1/4"-20 x 1" SHCS / Zinc / GR8	7
11.3.2	K1126	Flange Nut 1/4"-20	7

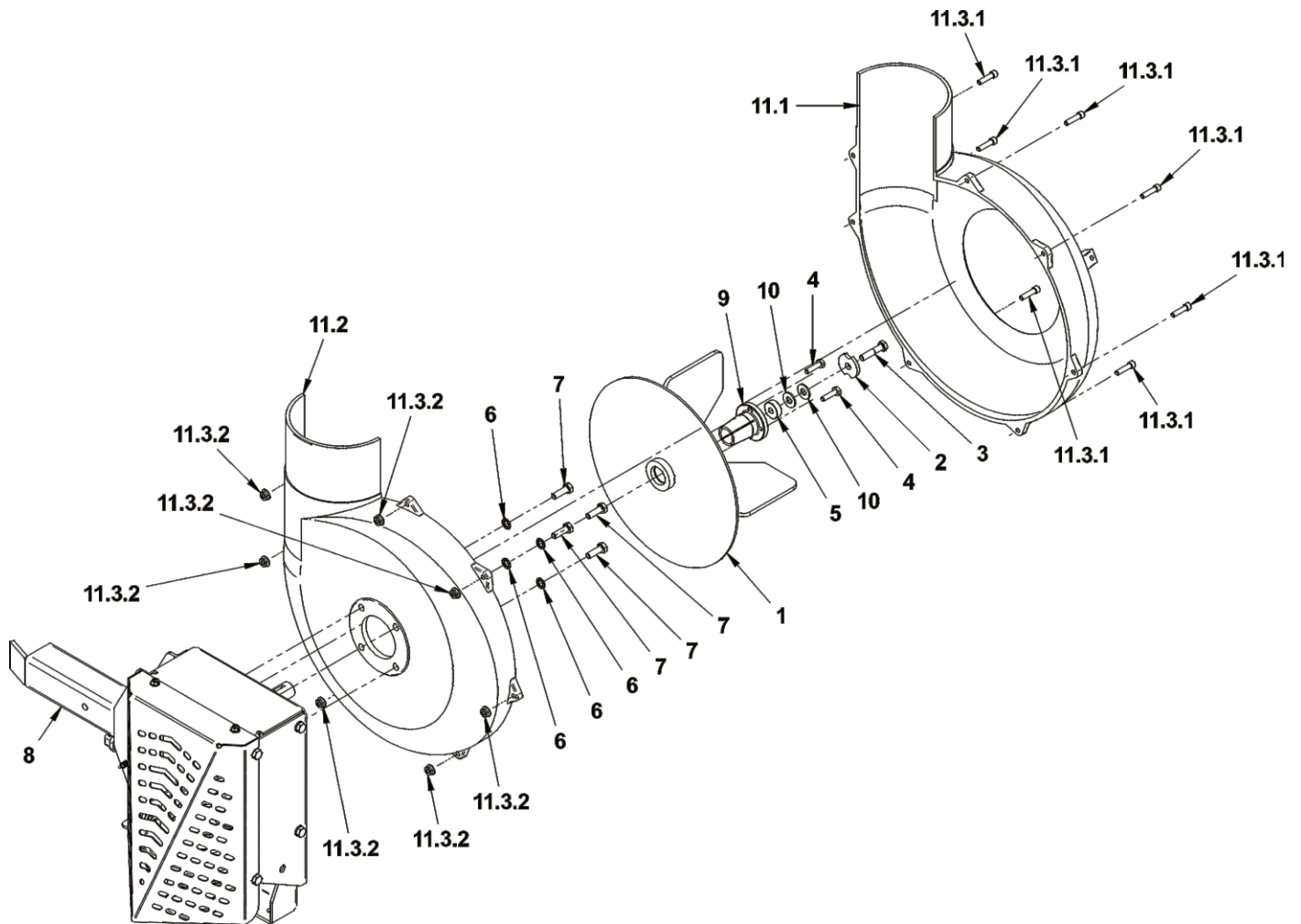

A2107 Latch Rod Assembly Exploded Parts View

Item #	Part #	Desc.	Qty.
1	B1000	Latch Rod / Hook Side	1
2	K0400	1/2" Flat Washer 1.084 OD x .528 ID x .120 T	2
3	J0303	Spring	1
4	K0086	Hair Pin Clip .125 OD x 2.50	1
5	A2106	Latch Rod Weldment	1

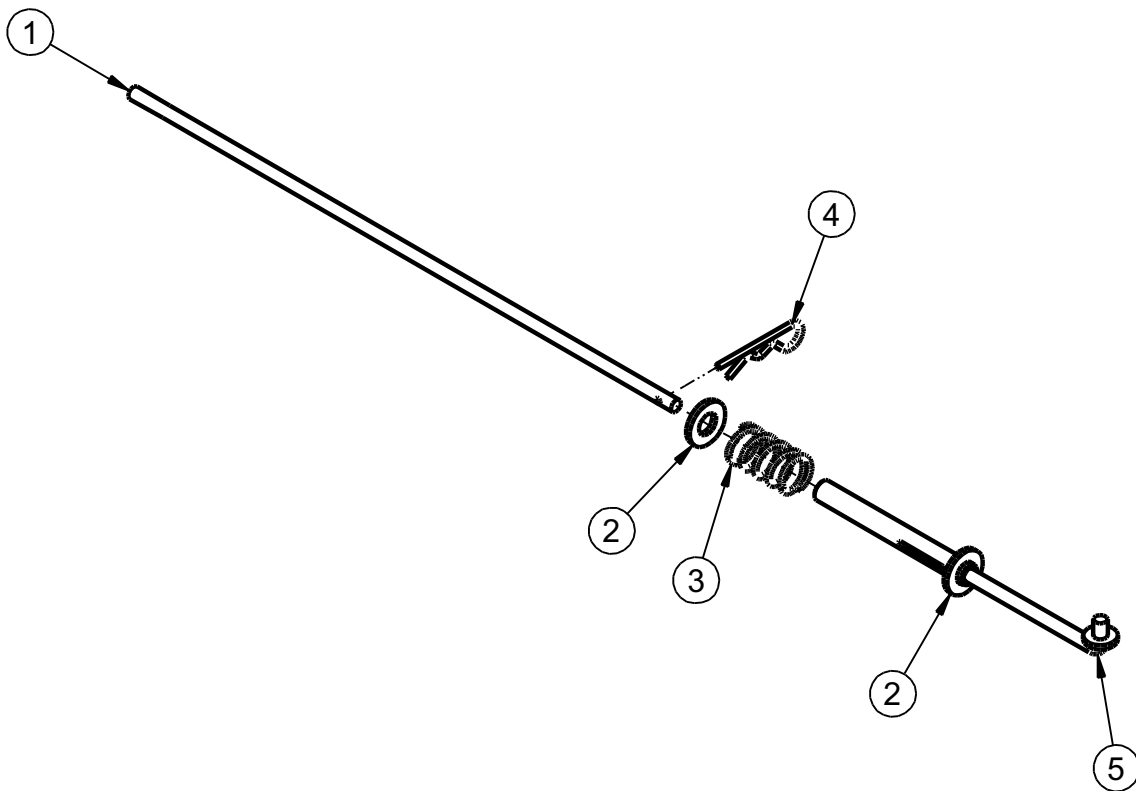



Unit Model #: 23651201

Mower & Type: Bob-Cat ProCat, ProCat MX & Predator Pro

Owner's Manual: Q0548

Mower Model: 6000 Series, 6000MX Series, 7001 & 7002

Deck Size: 52" - 61"

Vac Type: P12

Deck Type: AirFX

Drive Type: PTO-X

Revision #: 0

Fits Year(s): 2019-Newer

<p><input type="checkbox"/> A2274 Vac Kit</p> <p>(1) HB0799 Vac Kit Hardware Bag (1) F0080-38 8" x 38" Lower Hose (1) C0088 Debris Deflector (1) C0074 Inlet Ring (Split Cut) (1) V0025 6" & 7" Plastic Inlet (1) F0060-34 6" x 34" Upper Hose (1) B1943 Right Main Frame Leg (1) A0897 Box Handle Assy. (2) J0080 8" Hose Clamp (2) J0060 6" Hose Clamp (1) B1942 Left Main Frame Leg</p>	<p><input type="checkbox"/> A2273 Mount Kit</p> <p>(1) HB0798 Mount Kit Hardware Bag (1) B1938 Top Bracket/ Mount Arm (1) B1939 Bottom Bracket/ Mount Arm (1) HB0802 Wiring Harness Hardware Bag (1) A2069_02 Belt Guard Assy. (1) A2067_02 Idler Mount Assy. (1) E6009 8" Blower Cone (1) HB0801 Engine Pulley Hardware Bag (1) A2061_02 Drive Assy. w/ 4-Blade Impeller (1) M0322 AK80 Belt</p>	<p><input type="checkbox"/> A2174 Boot Kit</p> <p>(1) B1062 Boot Plate (1) E1030 Boot (1) B0288 Boot Rod (1) HB0393 Hardware Hardware Bag</p> <p><input type="checkbox"/> A2121 Dual Weight Kit / Single Caster</p> <p>(1) HB0687 Hardware Hardware Bag (2) Y0025 28 lb. Weight (1) B1015 Weight Bracket Clamp (1) B1014 Dual Weight Bracket Base</p> <p><input type="checkbox"/> A2121 Dual Weight Kit / Single Caster</p> <p>(1) HB0687 Hardware Hardware Bag (2) Y0025 28 lb. Weight (1) B1015 Weight Bracket Clamp (1) B1014 Dual Weight Bracket Base</p>
---	---	---

SAFETY DECALS

To promote safe operation, New PECO, Inc. supplies safety decals on all products manufactured. Damage can occur to safety decals either through shipment, use or reconditioning. Contact your local Service Center for replacement decals.



Part# R1070
PECO Logo



Part# R0022
Designed & Built
In The USA



Part #: R2007
Danger - Never Use Hands



Part #: R2008
Danger - Rotating Blades

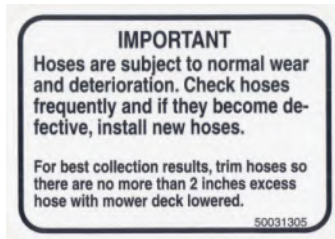

Part #: R1054
Important - Hose Wear

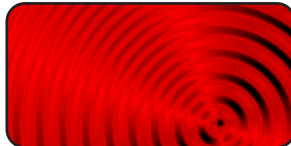
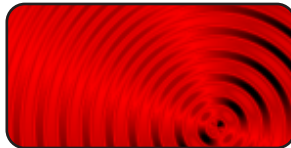

Part #: R1057 - (2)
Red Reflectors



Part #: R1069
Warning - Turn Off Blower



Part # R0024
Danger - Keep Hands
Clear



Part #: R1051
Warning - Hearing Protection



Part # R0025
Danger - Rotating
Blades

SECTION III OPERATING INSTRUCTIONS

General Safety

Only qualified people familiar with this operator's manual and the mower's operator's manual should operate this machine.

Operation And Tips On Mowing

- A. Perform BEFORE EACH USE the maintenance list referenced in Section IV.
- B. Start mower.
- C. With the mower at high idle speed, engage the mower deck.
- D. While seated in the operator's seat, move Bagger PTO switch to the on position. With the PTO assembly engaged, you can proceed to operate the control levers of the mower.

NOTE: If the collection system does not appear to be collecting the grass clippings, disengage the deck and PTO assembly, then, engage the parking brake and turn the mower off. Check upper and lower hoses for any clogs.

To obtain the maximum effectiveness from your collection system, the tips listed below should be followed:

- * Watch your speed- Normal conditions will allow a speed of up to approximately 4 mph, but thick, heavy damp conditions will require reduced ground speed.
- * Mow with sharp blades- A sharp blade cuts cleaner.
- * Wet grass and leaves will decrease effectiveness and will increase horsepower requirements.
- * Mow at higher cutting heights- Remove and mulch no more than 2" of grass length with each mowing. (Experts recommend not cutting off more than 1/3 of the grass blade length at any given time.)
- * Mow twice, at different height settings, (high, then low), if grass is extra tall.
- * Remember that horsepower requirements will vary with the mowing conditions such as type and height of turf grass, moisture content, amount of leaves, whether the terrain is flat or hilly, etc.

Disengagement Of The PTO Assembly

- A. To disengage the PTO assembly, move Bagger PTO switch to the off position.

WARNING: DO NOT TOUCH the PTO assembly, pulleys, or the belt until the tractor is turned off.

Unloading The Collection System

- A. Stop the forward movement of the mower, engage the parking brake.
- B. Disengage the mower deck.
- C. Disengage the blower.
- D. Verify that the dump area is clear.
- E. Push the dump handle, on the left of the operator, away from the unit. While holding the handle pushed away, move the handle upward. The container door will swing upward and the container will rotate downward. The container will release its contents.
- F. Once the contents of the container have fallen out, the container is ready to move back into its normal operating position. Pull the handle downward until positive latching is achieved.

NOTE: Do not allow collection system to become over-filled as potential damage may occur to your equipment. Also, be sure to clean the screen as needed.

SECTION IV MAINTENANCE

Maintenance Checklist

Before each use:

1. Check blades and spindles to be sure that no foreign objects, such as wire or steel strapping bands, are wrapped around them.
2. Inspect blades for wear. Replace if necessary. If it is necessary to sharpen the blades, remove the blades from the spindles before sharpening. DO NOT sharpen blades while still attached to the mower.

3. Make sure all shields are in place and in good condition. Repair or replace any missing or damaged shields.
4. Perform lubrication per instructions.
5. Listen for abnormal sounds, which might indicate loose parts, damaged bearings, or other damage. Correct any deficiency before continuing operation.
6. With the engine off, engage the blower assembly. Check the belt tension and inspect the pulley belt for cracks or tears.
7. Check for wear or deterioration of the upper or lower hoses. If there are any portions of the hose that have been torn or worn through, replace immediately.

After Each Use:

1. Clean all debris from machine especially from the container, underneath the belt shields, and safety decals. Replace any missing or illegible decals.
2. Under normal usage, the collection unit is subject to deterioration and wear. Inspect the unit for worn or damaged components. Repair or replace before the next use. Any replacement component installed during repair shall include the component's current safety decal specified by the manufacturers to be affixed to the component.
3. Check belt for proper tension.

Lubrication

Gearbox:

NOTE: The gearbox is filled with 6.0 oz. of Mobilube HD Plus 80W-90 oil and permanently sealed. There is no need for scheduled lubrication. The oil level should only be checked if a leak is observed or if a change in gearbox noise is noticed.

Operators are recommended to check for leaks weekly. If a leak is observed, both the gasket and the seals are recommended to be replaced.

Replace the oil using 5.5 oz. of the recommended Mobilube HD Plus 80W-90 oil. Be sure to not overfill.

Blower Assembly:

NOTE: The following is for older PTO models that contain a greaseable zirc fitting. Newer models contain maintenance-free bearings and are without a greasable fitting.

1. On initial use: Grease the fitting on the blower shaft.
2. Every 25 hours of use: Re-grease the grease fitting.

NOTE: Use only white lithium based grease for lubrication of the shaft on the blower assembly.

SECTION V - PARTS & SERVICE

Parts And Service Information

Collection system owners should record the name and telephone number of their Service Center. Your Service Center will be happy to supply replacement parts, accessories, and do any service or repairs to your collection system. If for any reason your Service Center is unable to service your collection system or supply replacement parts, contact New PECO, Inc. and include the following information on the chart below.

DOCUMENT THE FOLLOWING INFORMATION FOR FUTURE REFERENCE

Unit Model Number: _____

Unit Engine Size: _____

Unit Serial Number: _____

Date of purchase: _____ / _____ / _____

Dealer/Distributor Name: _____

Address: _____ **State:** _____ **Zip:** _____

Phone Number: _____

New PECO, Inc.

10 Walden Dr | Arden, North Carolina 28704

Phone: 1-800-438-5823 | 828-684-1234

Fax: 828-684-0858

Email: peco@lawnvac.com

Website: www.lawnvac.com

TORQUE SPECIFICATIONS

Proper torque for American fasteners used on Peco equipment.
Recommended Torque in Foot Pounds (Newton Meters).*

AMERICAN Bolt Head Markings

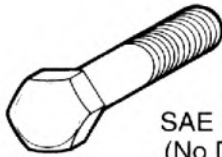

SAE Grade 2
(No Dashes)

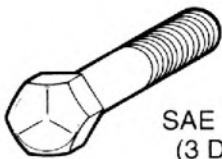

SAE Grade 5
(3 Dashes)

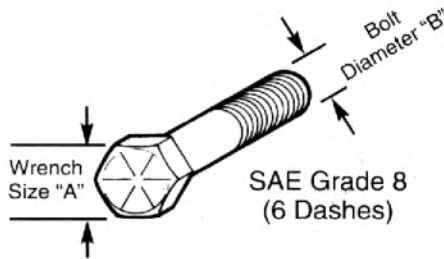

SAE Grade 8
(6 Dashes)

WRENCH SIZE (IN.) "A"	BOLT DIAMETER (IN.) "B" AND THREAD SIZE	SAE GRADE 2	SAE GRADE 5	SAE GRADE 8
7/16	1/4 - 20 UNC	6 (7)	8 (11)	12 (16)
7/16	1/4 - 28 UNF	6 (8)	10 (13)	14 (18)
1/2	5/16 - 18 UNC	11 (15)	17 (23)	25 (33)
1/2	5/16 - 24 UNF	13 (17)	19 (26)	27 (37)
9/16	3/8 - 16 UNC	20 (27)	31 (42)	44 (60)
9/16	3/8 - 24 UNF	23 (31)	35 (47)	49 (66)
5/8	7/16 - 14 UNC	32 (43)	49 (66)	70 (95)
5/8	7/16 - 20 UNF	36 (49)	55 (75)	78 (106)
3/4	1/2 - 13 UNC	49 (66)	76 (103)	106 (144)
3/4	1/2 - 20 UNF	55 (75)	85 (115)	120 (163)
7/8	9/16 - 12 UNC	70 (95)	109 (148)	153 (207)
7/8	9/16 - 18 UNF	79 (107)	122 (165)	172 (233)
15/16	5/8 - 11 UNC	97 (131)	150 (203)	212 (287)
15/16	5/8 - 18 UNF	110 (149)	170 (230)	240 (325)
1-1/8	3/4 - 10 UNC	144 (195)	266 (360)	376 (509)
1-1/8	3/4 - 16 UNF	192 (260)	297 (402)	420 (569)
1-5/16	7/8 - 9 UNC	166 (225)	430 (583)	606 (821)
1-5/16	7/8 - 14 UNF	184 (249)	474 (642)	668 (905)
1-1/2	1 - 8 UNC	250 (339)	644 (873)	909 (1232)
1-1/2	1 - 12 UNF	274 (371)	705 (955)	995 (1348)
1-1/2	1 - 14 UNF	280 (379)	721 (977)	1019 (1381)
1-11/16	1-1/8 - 7 UNC	354 (480)	795 (1077)	1288(1745)
1-11/16	1-1/8 - 12 UNF	397 (538)	890 (1206)	1444 (1957)
1-7/8	1-1/4 - 7 UNC	500 (678)	1120 (1518)	1817 (2462)
1-7/8	1-1/4 - 12 UNF	553 (749)	1241 (1682)	2013 (2728)
2-1/16	1-3/8 - 6 UNC	655 (887)	1470 (1992)	2382 (3228)
2-1/16	1-3/8 - 12 UNF	746 (1011)	1672 (2266)	2712 (3675)
2-1/4	1-1/2 - 6 UNC	870 (1179)	1950 (2642)	3161 (4283)
2-1/4	1-1/2 - 12 UNF	979 (1327)	2194 (2973)	3557 (4820)

METRIC

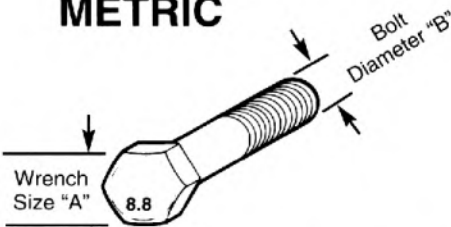

Numbers appearing on bolt heads indicate ASTM class.

Proper torque for metric fasteners used on Peco equipment.
Recommended torque in foot pounds (newton Meters).*

WRENCH SIZE (mm) "A"	BOLT DIA. (mm) "B"	ASTM 4.6	ASTM 8.8	ASTM 9.8	ASTM 10.9
8	5	1.8 (2.4)		5.1 (6.9)	6.5 (8.8)
10	6	3 (4)		8.7 (12)	11.1 (15)
13	8	7.3 (10)		21.1 (29)	27 (37)
16	10	14.5 (20)		42 (57)	53 (72)
18	12	25 (34)	74 (100)	73 (99)	93 (126)
21	14	40 (54)	118 (160)	116 (157)	148 (201)
24	16	62 (84)	167 (226)	181 (245)	230 (312)
30	20	122 (165)	325 (440)		449 (608)
33	22		443 (600)		611 (828)
36	24	211 (286)	563 (763)		778 (1054)
41	27		821 (1112)		1138 (1542)
46	30	418 (566)	1119 (1516)		1547 (2096)

*Use 75% of the specified torque value for plated fasteners. Use 85% of the specified torque values for lubricated fasteners.

Troubleshooting

2017 (v1.0)

Collection System Performance

Problem	Possible Cause	Corrective Action
Abnormal Vibration	<ul style="list-style-type: none"> • Cutting blades are bent or unbalanced • Loose blower pulley or pulley assembly • Impeller blade out of balance 	<ul style="list-style-type: none"> • Install new cutting blade • Tighten the pulley • Contact dealer to replace
Reduced collection system performance	<ul style="list-style-type: none"> • Low engine speed • Plugged screen • Loose belt • Full collection bags 	<ul style="list-style-type: none"> • Always operate collection system at full throttle • Remove debris, leaves, or grass clippings from the screen • Replace/tighten belt • Empty the collection bags
Blower and hoses plugging too frequently	<ul style="list-style-type: none"> • Collection bags are too full • Low engine speed • Grass is too wet • Grass is too long • Ground speed is too fast • Worn belt • Loose belt 	<ul style="list-style-type: none"> • Dump more frequently • Always operate collection system at full throttle • Cut grass when it is dry • Cut the grass several times • Drive slower at full throttle • Replace belt • Adjust the pulley and tighten belts
Debris blowout	<ul style="list-style-type: none"> • Collection bags are too full • Plug/clog in the collection system • Ground speed is too fast 	<ul style="list-style-type: none"> • Dump more frequently • Clean the collection system • Drive more slowly at full throttle
Impeller doesn't rotate freely	<ul style="list-style-type: none"> • Plug in the blower housing • Worn impeller blade • Shaft bearings bad/failing 	<ul style="list-style-type: none"> • Clean the blower housing • Contact dealer to replace • Contact dealer to replace

Notes



New PECO, Inc.
10 Walden Dr | Arden, North Carolina 28704
Phone: 1-800-438-5823 | 828-684-1234
Fax: 828-684-0858
Email: peco@lawnvac.com
Website: www.lawnvac.com