



PTO-X DRIVEN - GRASS COLLECTION SYSTEM

Model# 49651202

COUNTRY
CLIPPER
ZERO TURN MOWER

Charger 8000 & Boss XL 9000
Mower Year: 2021

Charger 8005 & Boss XL 9005
Mower Year: 2022-Newer



Deck Size: 60"

OPERATOR'S MANUAL

ASSEMBLY • OPERATION • MAINTENANCE

GRASS COLLECTION SYSTEM

TABLE OF CONTENTS

SECTION	PAGE	SECTION	PAGE
Safety	2	Inlet, Inlet Ring & Debris Deflector Installation	28
Safety Alert Symbols	3	Boot Kit Assy & Installation	29
Warranty	4	Blower Cone Installation	30
I INTRODUCTION AND DESCRIPTION	5	Length of Hose Adjustment	31
Introduction	5	Upper Hose Installation	31
Description	5	Lower Hose to Blower Cone Installation	31
II INSTALLATION FOR USE	5	Lower Hose to Boot Installation	31
Preparation Of Mower	6-7	Wire Harness Installation	32-35
Rear Frame Bracket Installation	8-9	Weight Kit Installation	36
Side Frame Spacer Installation	10	Impeller Blade Removal/Replacement	37
Right & Left Frame Bracket Installation	11-12	Exploded Views & Parts List	38-49
Frame Gusset Installation	13-14	Overall Parts List	50
Mount Arm / Top Bracket Installation	15	Safety Decals	51
Mount Arm / Bottom Bracket Installation	15	III OPERATING INSTRUCTIONS	52
Mount Arm / Gusset Installation	16	General Safety	52
Mount Arm / Tube Assembly Installation	17	Operation & Tips On Mowing	52
Lower Mount Tube Installation	18	Disengagement Of The PTO Assembly	52
Upper Frame Assy Installation	19	Unloading The Collection System	52
PTO Drive Assembly	20-21	IV MAINTENANCE	52-53
Drive Assy & Belt Installation	22	Maintenance Checklist	53
Belt Tension Adjustment	23-25	Lubrication	53
Lift Handle Installation	26	V PARTS AND SERVICE	53
Aluminum Box Assy Installation	27	Parts And Service Information	53
Dump Mechanism Adjustment	27	Torque Specifications	54
		Troubleshooting	55

SAFETY

1. Read the operator's manual carefully and familiarize yourself with the proper use of your attachment. Do not allow anyone who is not acquainted with the Safety Instructions to use your attachment.
2. Know the controls and how to stop them quickly. **READ THE OPERATOR'S MANUAL!**
3. Do not allow children to operate the machine. Do not allow adults to operate it without proper instruction.
4. Be especially watchful of children and pets entering into the area while operating.
5. Keep your eyes and mind on your machine while mowing or operating your attachment. Don't let others distract you.
6. Do not attempt to operate your machine when not in the driver's seat.
7. Always shut off blades and engine when emptying the container.
8. Stop machine, shut off deck attachment, set parking brake, shut off engine and remove ignition key before removing clogs, removing or replacing hose, boot, blower cone, or performing any maintenance.
9. Mow across the face of slopes (not more than 10 degrees); never up and down the face.
10. It is recommended that the container be emptied when half full while operating on slopes. Start mowing on slopes when the container is empty.
11. Inspect your lawn and remove any foreign objects before mowing. Never deliberately run the mower across any foreign object.
12. Wear hearing protection.
13. Wear eye protection to prevent debris from getting into your eyes.

SAFETY

WARNING! NEVER operate the mower unless the discharge guard and either the deflector assembly or the vacuum collector adapter are fastened securely in place.

WARNING! Do not work around the mower deck boot or the blower area until you are certain that the mower blades and the blower impeller have stopped rotating.

WARNING! To avoid serious injury, perform maintenance on the vacuum collector; **ONLY AFTER STOPPING THE MOWER'S ENGINE AND WAITING FOR ALL MOVING PARTS TO COME TO A COMPLETE STOP.** Set the parking brake. Always remove the ignition key before beginning maintenance.

WARNING! For your own personal safety, **ALWAYS mow ACROSS the face of slopes and NEVER UP and DOWN the face. NEVER attempt to mow excessively steep slopes, and use caution when turning on any slope.**

Safety Alert Symbol



This Safety Alert Symbol means: **“ATTENTION! BECOME ALERT! YOUR SAFETY IS INVOLVED!”**

This symbol is used to call attention to safety precautions that should be followed by the operator to avoid accidents. When you see this symbol, carefully read the message that follows and heed its advice. Failure to comply with safety precautions could result in death or serious bodily injury.

Safety Signs

The signal words **DANGER**, **WARNING**, and **CAUTION** are used on the equipment safety signs. These words



White letters on **RED**

This signal word indicates a potentially hazardous situation which, if not avoided, will result in death or serious injury.



Black letters on **ORANGE**

This signal word indicates a potentially hazardous situation which, if not avoided, could result in death or serious injury.

It may also be used to alert against unsafe practices.



Black letters on **YELLOW**

This signal word indicates a potentially hazardous situation which, if not avoided, will result in minor or moderate injury.

It may also be used to alert against unsafe practices.

PECO LIMITED WARRANTY FOR NEW PRODUCTS

New PECO, Inc. extends the following warranties to the ORIGINAL PURCHASER of each New PECO, Inc. consumer product purchased from one of our Dealers or directly from New PECO, Inc., subject to the following limitations:

A. ITEMS COVERED UNDER WARRANTY

1. **PRODUCT WARRANTY** – Any part or parts which are deemed defective in material or workmanship, as delivered to the original purchaser, will either be repaired or replaced, as New PECO, Inc. elects, without charge for parts or labor, if the defect appears within 12 months from the date of purchase of the product to the Original Purchaser.
2. **PARTS REPLACED DURING WARRANTY** – Any New PECO, Inc. part which is furnished in performance of this warranty and is defective in material or workmanship as delivered to the purchaser will be repaired or replaced, as New PECO, Inc. elects, before the expiration of the original warranty period.

B. WARRANTY DISTINCTIONS

1. **RESIDENTIAL** - Products put to a personal use around a single household or residence are considered Residential. Products designated as “Residential” are warranted for 12 months from the date of purchase of the product, to the ORIGINAL PURCHASER with proof of purchase, when used for or in residential applications.
2. **COMMERCIAL** – Products put to any business use (agricultural, commercial or industrial) or used at multiple locations are considered Commercial. Products designated as “Commercial” are warranted for 12 months from the date of purchase of the product, to the ORIGINAL PURCHASER with proof of purchase, when used for or in commercial applications. Products designated as “Residential” are warranted for 90 days from the date of purchase of the product, to the ORIGINAL PURCHASER with proof of purchase, when used for or in Commercial applications.
3. **RENTAL** – Products used for Rental or Lease Purposes are warranted for 45 days from date of purchase of the product, to the ORIGINAL PURCHASER with proof of purchase, when used for or in a rental business.

C. ITEMS NOT COVERED BY NEW PECO WARRANTY

1. **ENGINES & BATTERIES:** Engines and Batteries attached to New PECO, Inc. products are covered under their respective separate manufacturer warranties and those companies must be contacted directly to file a warranty claim. Briggs & Stratton: https://www.briggsandstratton.com/na/en_us/support/warranty.html
2. **UNAPPROVED ALTERATION OR MODIFICATION:** All obligations of New PECO, Inc. under this warranty shall be terminated if products are altered or modified in any way not approved by New PECO, Inc.
3. **ACCIDENTS & NORMAL MAINTENANCE:** This warranty covers ONLY manufacturers defective material and workmanship. It does not cover depreciation or damage caused by normal wear & tear, accident, improper maintenance, misuse or abuse of products. New PECO, Inc. products must be operated and maintained in accordance with the instructions furnished in the manuals. The cost of normal maintenance and normal replacement of service items such as belts, cutting blades, hoses, bags, etc., which are not defective shall be paid for by the purchaser.
4. **NO SERVICE CENTER WARRANTY:** The selling Service Center/Dealer makes no warranty on his own on any item warranted by New PECO, Inc. unless he delivers to purchaser a separate written warranty certificate specifically warranting the item. The Service Center or Dealer has no authority to make any representation or promise on behalf of New PECO, Inc. or to modify the terms of the original warranty in any way.
5. **NO REPRESENTATIONS ADDITIONAL WARRANTIES, DISCLAIMER:** Neither New PECO, Inc. nor any company affiliated with New PECO, Inc. makes any warranties, representations or promises as to the quality of performance of its products other than those set forth herein. Except as described above, New PECO, Inc. makes no other warranties **AND SPECIFICALLY DISCLAIMS ANY AND ALL IMPLIED WARRANTIES OF FITNESS AND MERCHANTABILITY.**
6. **REMEDIED EXCLUSIVE:** The only remedies the purchaser has in connection with the breach or performance of any warranty on New PECO, Inc. consumer products are set forth above. In no event will New PECO, Inc. be liable for special incidental or consequential damages.

Warranty service is available through your local authorized service dealer or distributor. If you do not know the dealer or distributor in your area, search by your zip code on www.lawnvac.com or contact our Sales Department at New PECO, Inc. 800-438-5823 or email Sales@lawnvac.com.

Section I - INTRODUCTION AND DESCRIPTION

Introduction

We are pleased to have you as a customer. Your collection system has been designed to give you a low maintenance, simple, and effective way to collect the grass clippings from your mower. This manual is provided to give you the necessary instructions to properly mount, operate and maintain the collection system on your mower. Please read this manual thoroughly. Understand what each control is for and how to use it. Observe all safety decal precautions on the machine and noted throughout the manual.

NOTE: All references made to right, left, front, rear, top or bottom are as viewed from the normal operator's position on the mower.

Description

The grass collection system is designed for turf maintenance where there is a need to collect the grass clippings as the mower cuts the turf. It is also used for picking up leaves in pre-season and post-season clean-up. The blower, mounted on the right side of the unit, uses a belt and gearbox system from the engine PTO shaft. Drive train protection comes through belt slippage. The blower draws grass clippings from the discharge area of the cutting deck back to the collection unit at the rear portion of the mower frame. The operator can engage the blower with a toggle Switch mounted on the right side of the operator. Once the collection unit is full with clippings, it can be easily released for dumping.

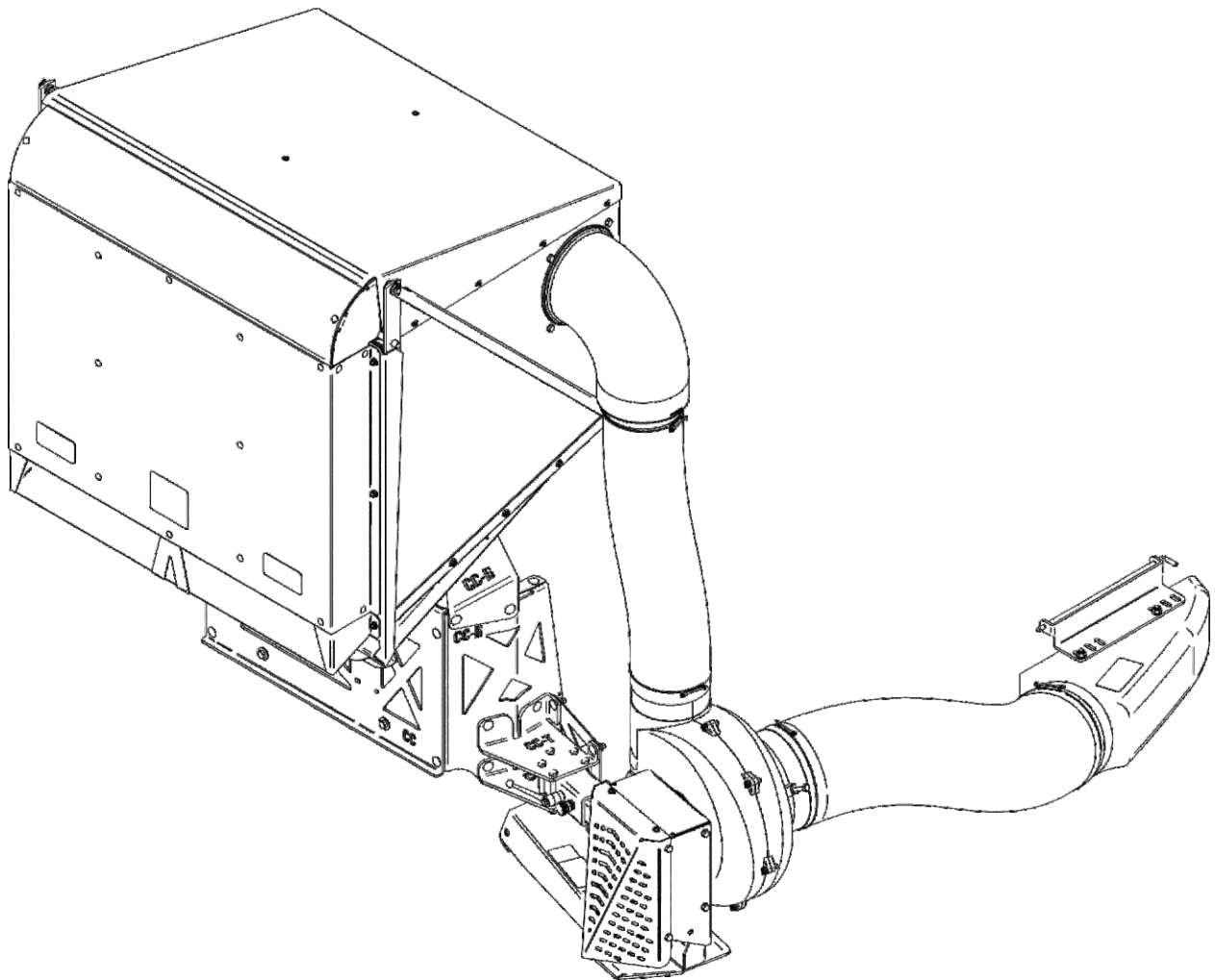

Note: There are different installation instructions between the model years. Installations for specific units will be specified under the current section heading or where needed as:

MY2021

or

MY2022

MY2021 & MY2022 will also share similar installation instructions. These instructions will not have any specification under the section heading.

Section II - INSTALLATION FOR USE

Preparation Of Mower

NOTE: The mower deck PTO belt must be removed from the electric clutch before continuing with the installation. Refer to your mower's owner's manual for instructions on PTO belt removal.

From the underside of the engine, disconnect the wiring harness attached to the electric clutch. Remove the bolt and electric clutch from the mower. Refer to Figure A.

Figure A

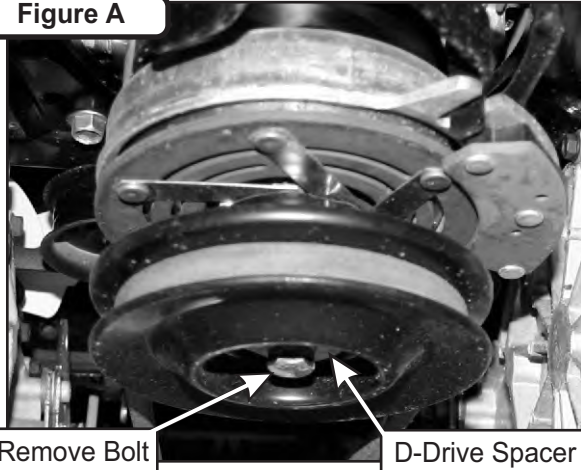

Upon removal of clutch determine if your mower is equipped with a D-drive spacer. If so, then proceed to Figure B. If your mower is equipped with bolt, fender and lock washer without D-drive spacer proceed to Figure C. Remove the D-drive spacer using an arbor press or equivalent. On removal, adjacent bearing OUTER race must be supported or bearing damage may occur. Refer to Figure B.

Figure B

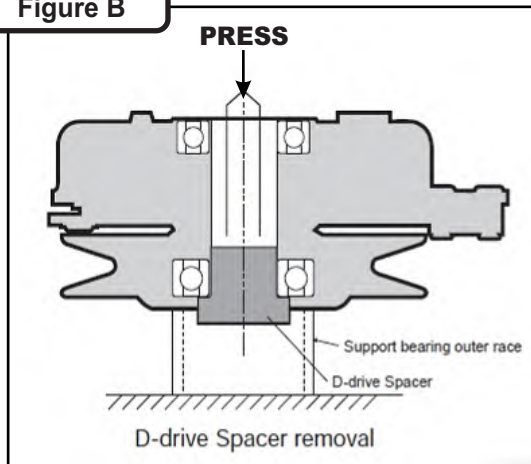
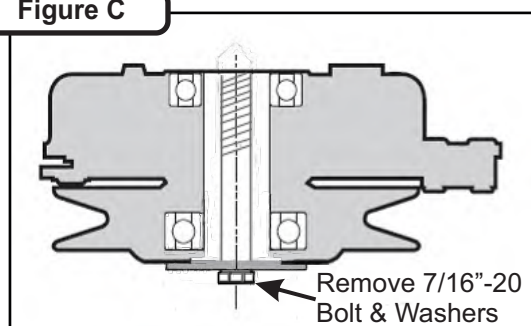
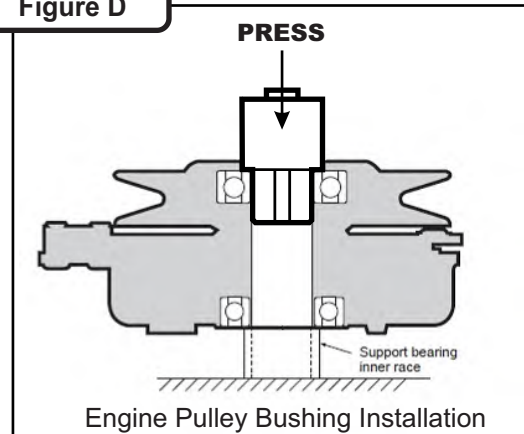

Figure C



The engine pulley assembly must be installed using an arbor press or equivalent. During installation, opposite bearing inner race must be supported or bearing damage may occur. Refer to Figure D.

Figure D



Once the Engine Pulley Bushing is installed, reattach the clutch assembly & deck PTO belt to the mower and then review Figure E.

Figure E

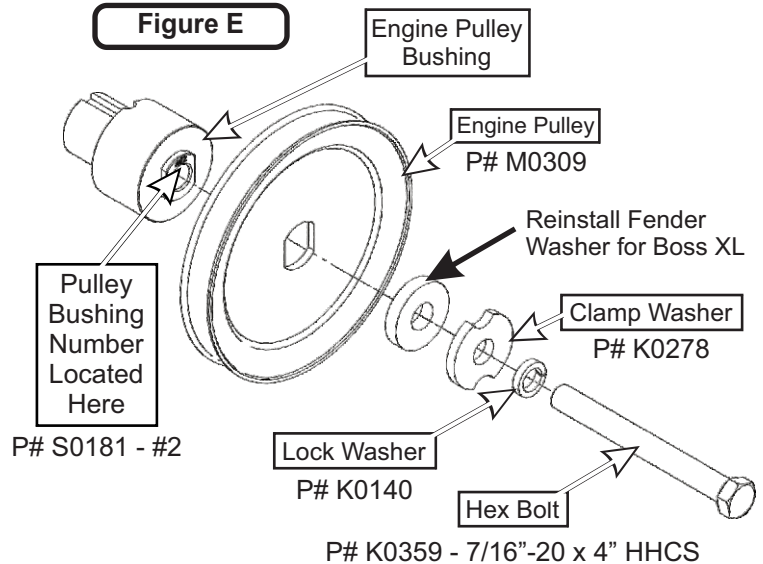

To assemble and fasten the Engine Pulley, align the Engine Pulley Bushing to the mower's clutch pulley and fasten using (1) Clamp Washer, (1) Lock Washer, and (1) Hex Bolt. Torque the bolt to 55 ft./lbs. For **Boss XL** units, reinstall the Fender Washer that was removed during the initial process. The added pulley will power the collection system and should resemble Figure F when installed.

Figure F

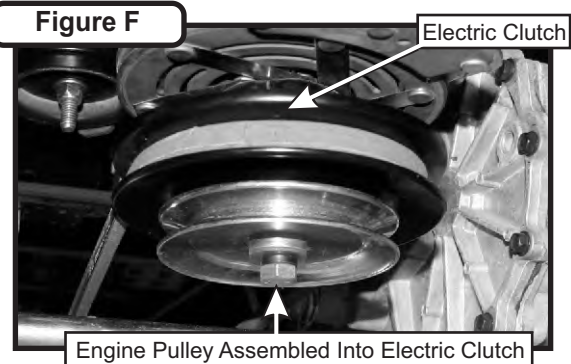

Preparation of Mower (Continued)

Before the installation of your unit, you will need to remove your mower's rear bracket along with the hardware holding it in place, see Figure G. Set the top set of hardware aside, see Figure H.

Note: Some parts and part features have been hidden from view for visual clarity.

Figure G

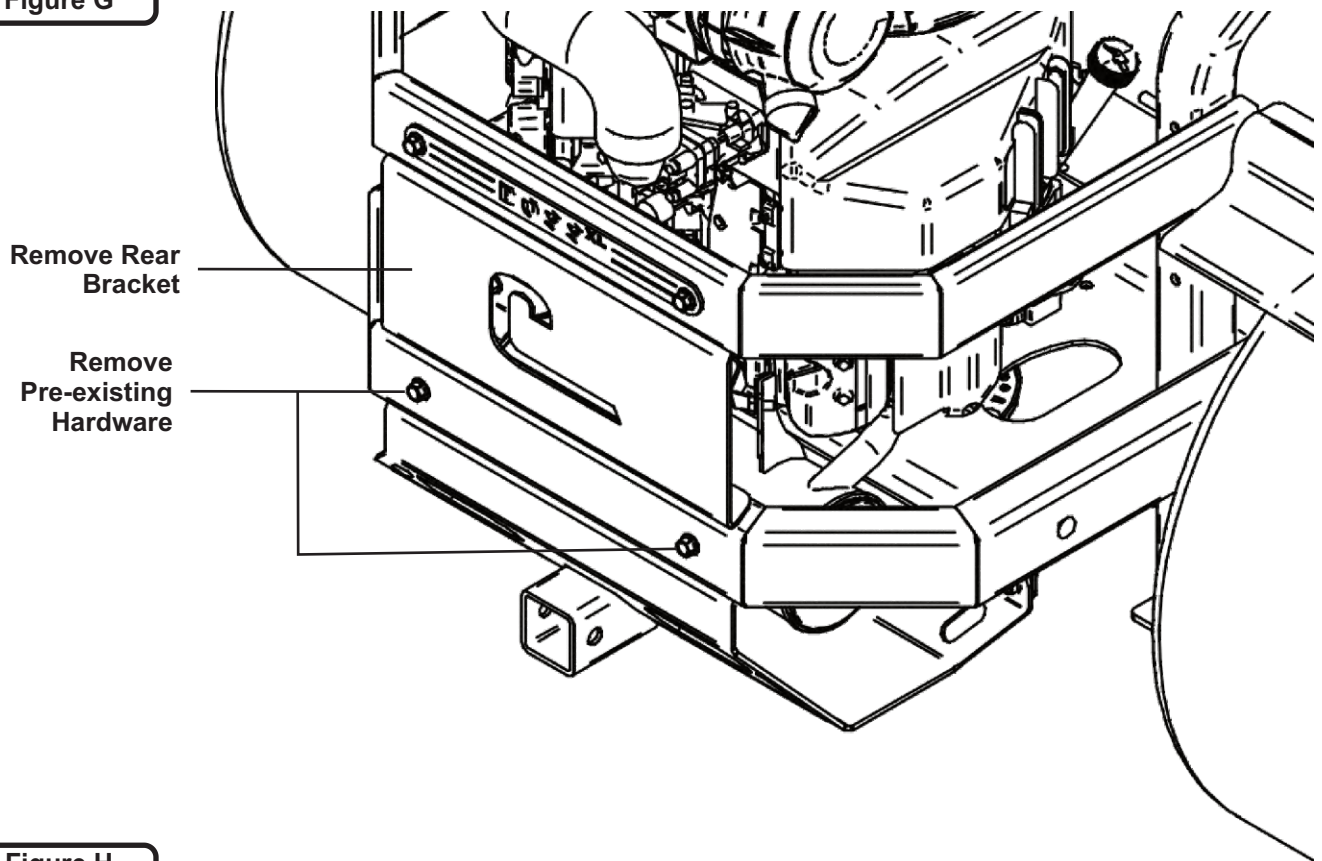
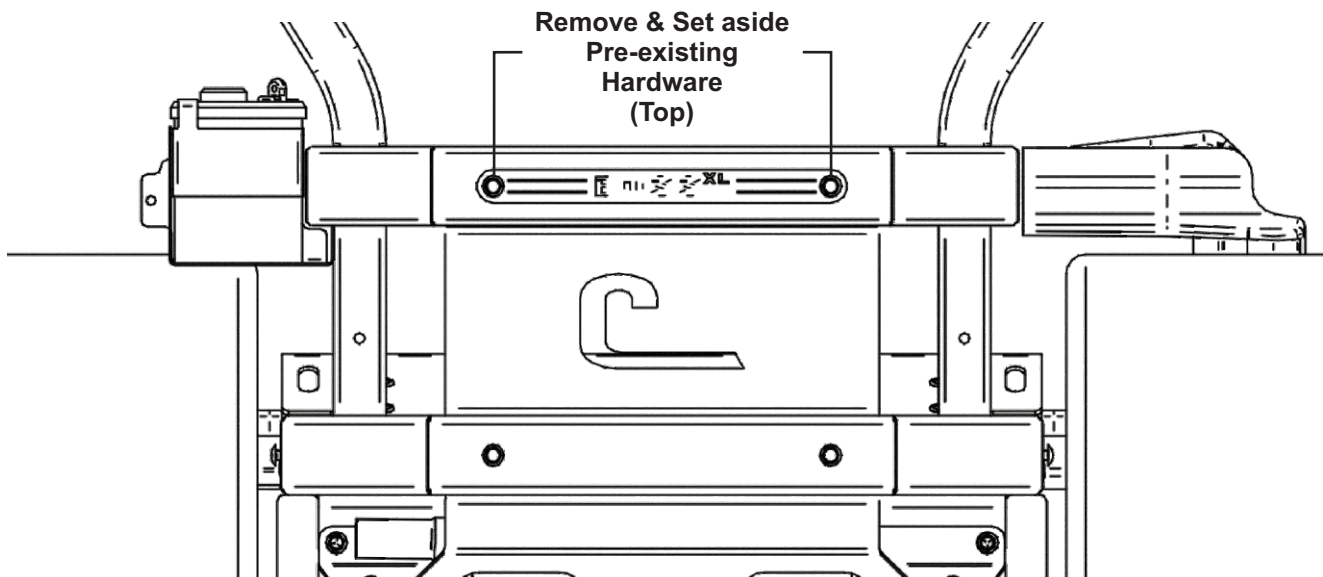

Figure H

Mower Rear View



Rear Frame Bracket Installation

MY2021

To install the Rear Frame Bracket (Item #1) align the mount holes of the Rear Frame Bracket to those on the Mower's rear frame, see the figure below.

Secure the Rear Frame Bracket by using the (2) previously removed hardware along the top of the Rear Frame Bracket, (2) 3/8"-16 x 2-3/4" HHCS (Item #2), (2) 3/8" Flat Washers (Item #3) and (2) 3/8"-16 Ny-Flange Lock Nuts (Item #4) along the bottom of the Rear Frame Bracket. See the Figure below.

Note: Some parts and part features have been hidden from view for visual clarity.

Figure A

Item #	Part #	Desc.	Qty.
1	B2073	Rear Frame Brkt.	1
2	K1021	3/8"-16 X 2-3/4" HHCS	2
3	K0047	Flat Washer 3/8" / 1.00 OD x .446 ID x .075 T	2
4	K2038	Ny-Flange Lock Nut 3/8"-16	2

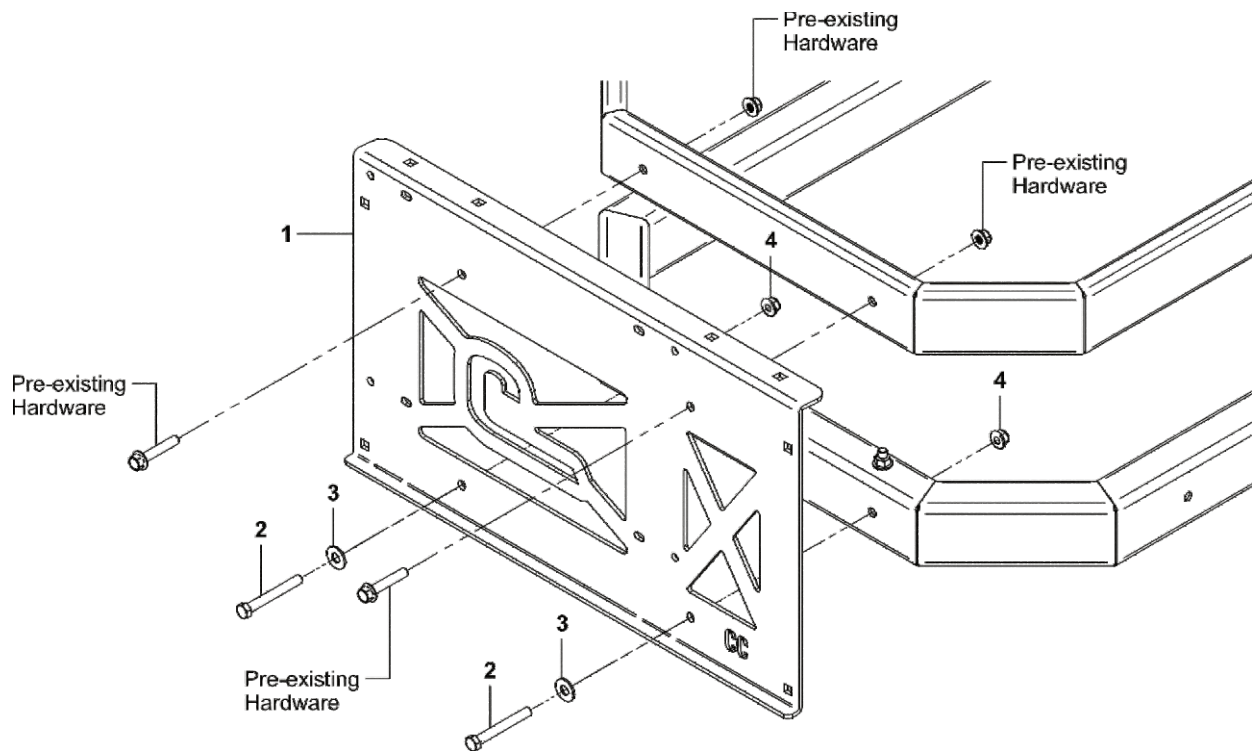

Rear Frame Bracket Installation (Cont.)

Before installing the Rear Frame Bracket (Item #2) for the MY2022 unit, a Frame Spacer (Item #1) would need to first be installed.

Position the Frame Spacer's (Item #1) mount holes to those on the Mower's rear frame, see Figure A below. Secure the Frame Spacer by using (2) 3/8"-16 x 2-3/4" HHCS (Item #3), (2) 3/8" Flat Washers (Item #4) and (2) 3/8"-16 Ny-Flange Lock Nuts (Item #5).

Once the Frame Spacer has been installed, align the mount holes of the Rear Frame Bracket (Item #2) to those on the Mower's rear frame, see Figure A below. Secure the Rear Frame Bracket by using the (2) sets of previously removed hardware along the top of the Rear Frame Bracket, (2) 3/8"-16 x 1" HHCS (Item #6), and (2) 3/8"-16 Ny-Flange Lock Nuts (Item #5) along the bottom of the Rear Frame Bracket.

Note: Some parts and part features have been hidden from view for visual clarity.

Figure A

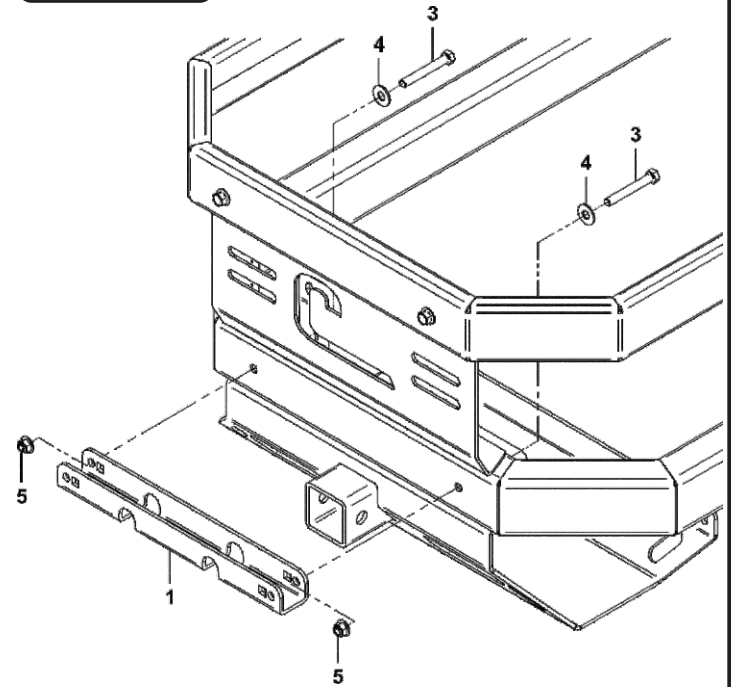

Item #	Part #	Desc.	Qty.
1	B2205	Frame Spacer / Boss XL 2020	1
2	B2073	Rear Frame Brkt.	1
3	K1021	3/8"-16 X 2-3/4" HHCS	2
4	K0047	Flat Washer 3/8" / 1.00 OD x .446 ID x .075 T	4
5	K2038	Ny-Flange Lock Nut 3/8"-16	4
6	K1191	HHCS 3/8"-16 x 1" GR5	2

Figure B

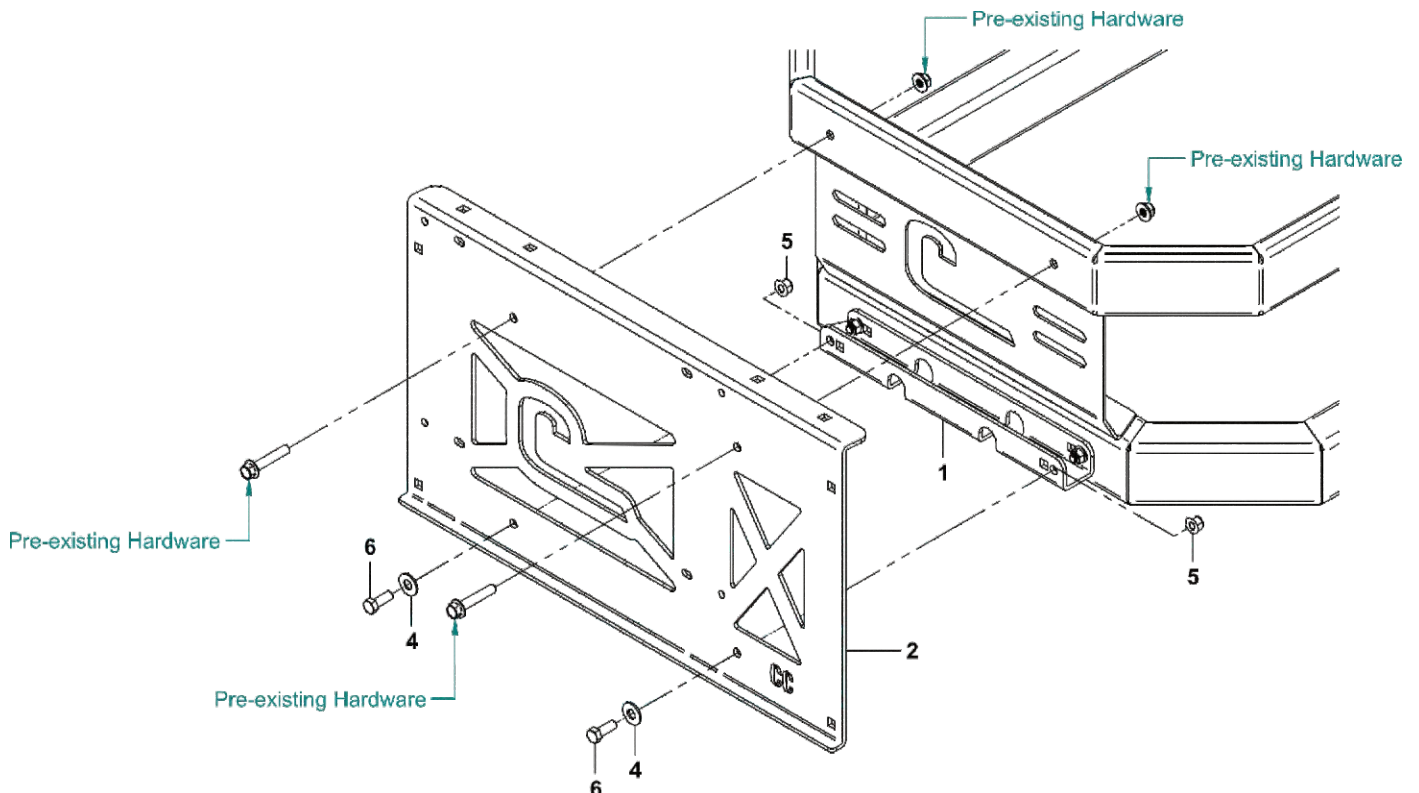

Side Frame Spacer Installation

MY2022

Before the Installation of the Left Frame Bracket P#(B2074) & Right Frame Bracket P#(B2075), pre install (1) Frame Spacer (Item #1) to each Bracket as shown in the Figures below.

To install the Frame Spacer (Item #1), align the bolt holes of the Frame Spacer to the side bolt holes of the Right Frame Bracket (Item #2) as shown in Figure A. Secure the Frame Spacer by using (2) 3/8"-16 x 1" Carriage Bolts (Item #3) and (2) 3/8"-16 Ny-Flange Lock Nuts (Item #4).

Repeat the steps for the Left Frame Bracket, see Figure B.

Note: Some parts and part features have been hidden from view for visual clarity.

Figure A

Item #	Part #	Desc.	Qty.
1	B2205	Frame Spacer / Boss XL 2020	1
2	B2075	Rt. Frame Brkt.	1
3	K1182	Carriage Bolt 3/8"-16 x 1"	2
4	K2038	Ny-Flange Lock Nut 3/8"-16	2

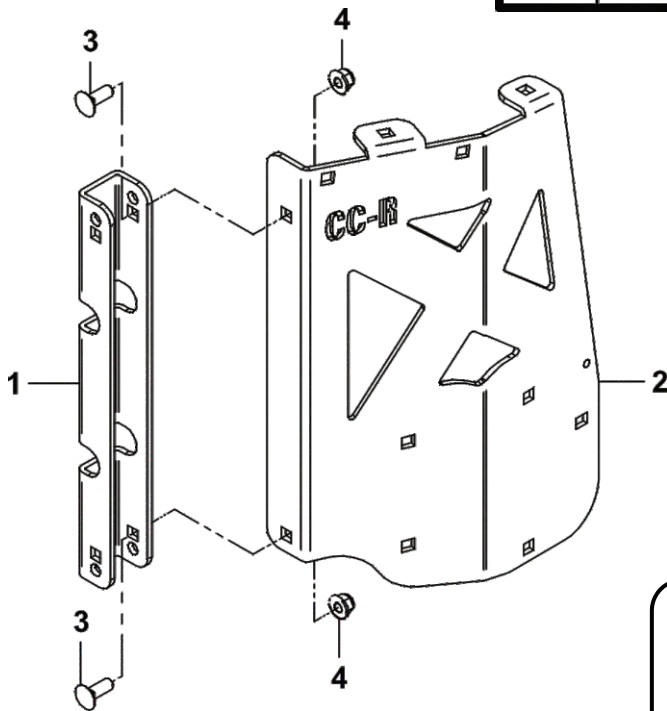
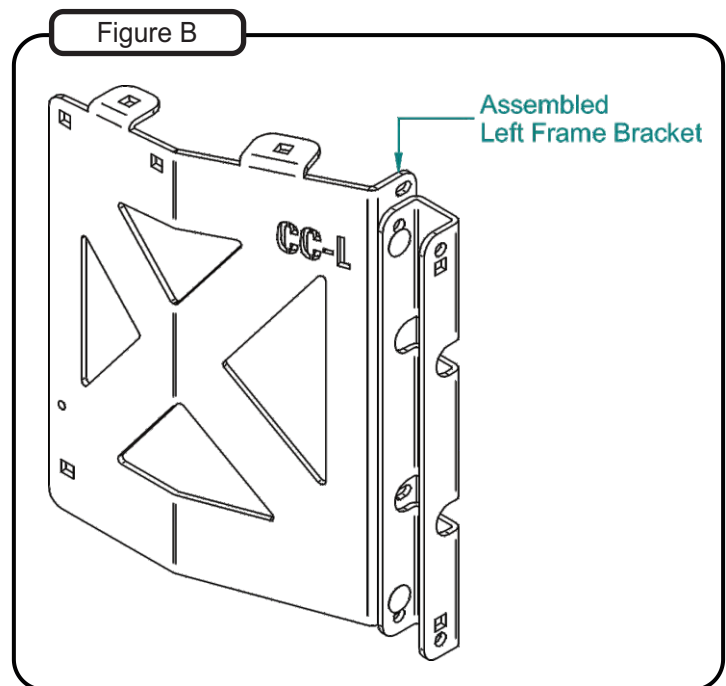

Figure B



Right & Left Frame Bracket Installation

MY2021

To install the Right Frame Bracket (Item #1) align and position the (2) mount holes located on the upright tab of the Right Frame Bracket (Item #1) to those located on the right side of the Rear Frame Bracket (Item #3). Secure the Right Frame Bracket, relatively loosely, by using (2) 3/8"-16 x 1" Carriage Bolt (Item #4) and (2) 3/8"-16 Ny-Flange Lock Nuts (Item #6). Refer to Figure A.

Once secured to the Rear Frame Bracket (Item #3), secure the Right Frame Bracket (Item #1) to the Mower by using (1) 3/8"-16 x 3" Carriage Bolt (Item #5) and (1) 3/8"-16 Ny-Flange Lock Nut (Item #6). See Figure B. Tighten All hardware at this time.

Repeat the same procedures for the installation of the Left Frame Bracket (Item #2), see Figure A.

Note: Some parts and part features have been hidden from view for visual clarity.

Figure A

Item #	Part #	Desc.	Qty.
1	B2075	Rt. Frame Brkt.	1
2	B2074	Lt. Frame Brkt.	1
3	B2073	Rear Frame Brkt.	2
4	K1182	Carriage Bolt 3/8"-16 x 1"	4
5	K1187	3/8"-16 x 3" Carriage Bolt	2
6	K2038	Ny-Flange Lock Nut 3/8"-16	6

Right Side View

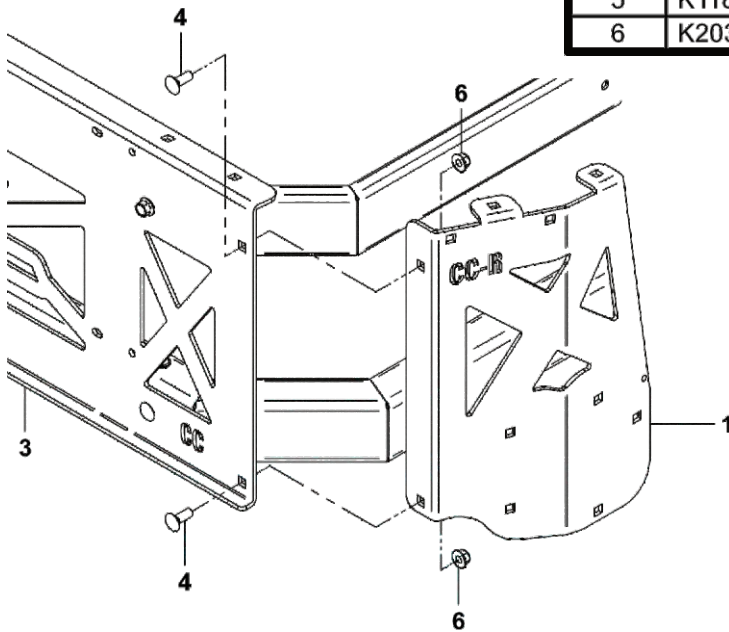
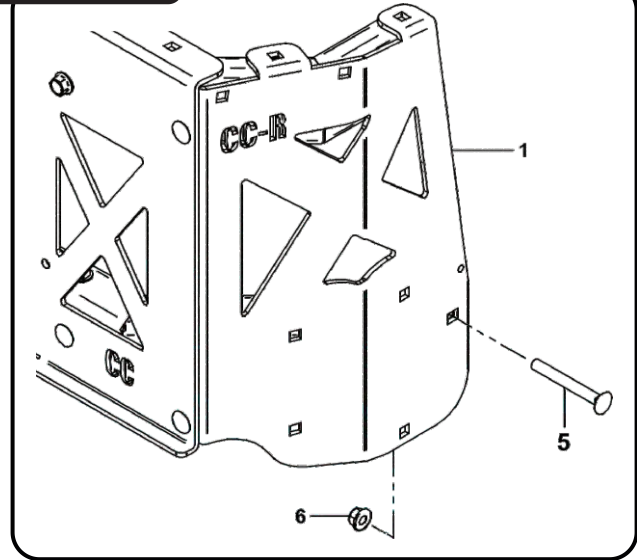
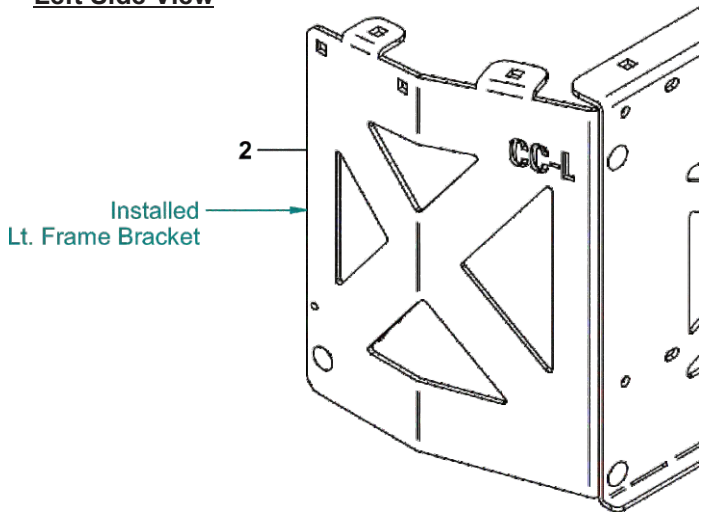

Figure B



Left Side View



Right & Left Frame Bracket Installation (Cont.)

MY2022

To install the pre-installed Right Frame Bracket (Item #1) from the previous step, align and position the (2) mount holes located on the Frame Spacer (Item #3) of the pre-installed Right Frame Bracket to those located on the right of the Rear Frame Bracket. Secure the Frame Spacer, relatively loosely, by using (2) 3/8"-16 x 1" Carriage Bolt (Item #4) and (2) 3/8"-16 Ny-Flange Lock Nuts (Item #6). Refer to Figure A.

Once secured to the Rear Frame Bracket, secure the Right Frame Bracket to the Mower by using (1) 3/8"-16 x 3" Carriage Bolt (Item #5) and (1) 3/8"-16 Ny-Flange Lock Nut (Item #6). See Figure B. Tighten All hardware at this time.

Repeat the same procedures for the installation of the pre-installed Left Frame Bracket (Item #2). See Figure A.

Note: Some parts and part features have been hidden from view for visual clarity.

Figure A

Item #	Part #	Desc.	Qty.
1	B2075	Rt. Frame Brkt.	1
2	B2074	Lt. Frame Brkt.	1
3	B2205	Frame Spacer / Boss XL 2020	1
4	K1182	Carriage Bolt 3/8"-16 x 1"	2
5	K1187	3/8"-16 x 3" Carriage Bolt	1
6	K2038	Ny-Flange Lock Nut 3/8"-16	3

Right Side View

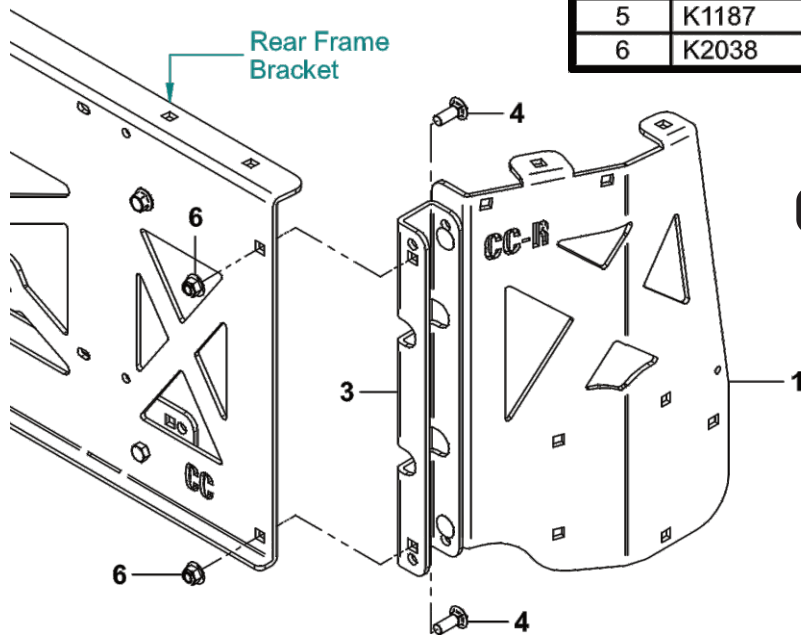
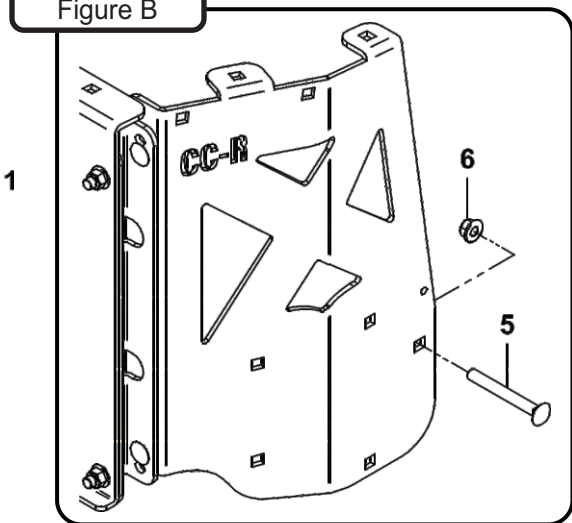
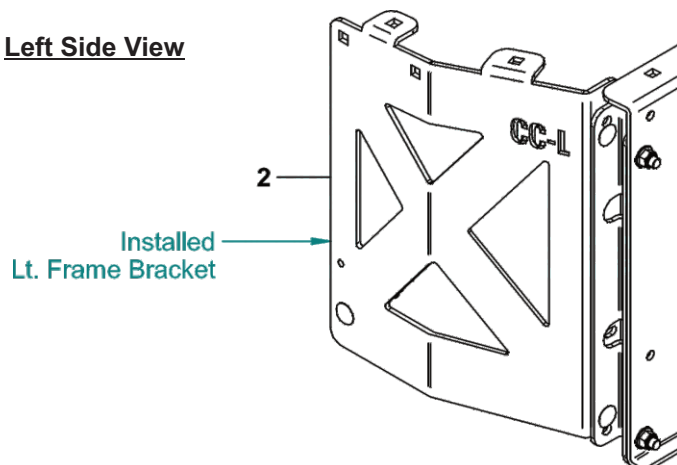

Figure B



Left Side View



Frame Gusset Installation

MY2021

Your Frame Gussets (Item #1) will have (2) different sets of bolt holes for your specific Mower model, see Figure B.

To install the Frame Gusset (Item #1) on the right side, align and position the mount holes of the Frame Gusset over the mount holes located on the top right of the Rear Frame Bracket and the top of the Right Frame Bracket. Secure the Frame Gusset, relatively loosely, by using (4) 3/8"-16 x 1" Carriage Bolt (Item #2) and (4) 3/8"-16 Ny-Flange Lock Nuts (Item #3). Refer Figure A below.

Repeat the same procedures to install the left side Frame Gusset. Once installed, tighten at this time.

Note: Some parts and part features have been hidden from view for visual clarity.

Figure A

Item #	Part #	Desc.	Qty.
1	B2081	Frame Gusset	1
2	K1182	Carriage Bolt 3/8"-16 x 1"	4
3	K2038	Ny-Flange Lock Nut 3/8"-16	4

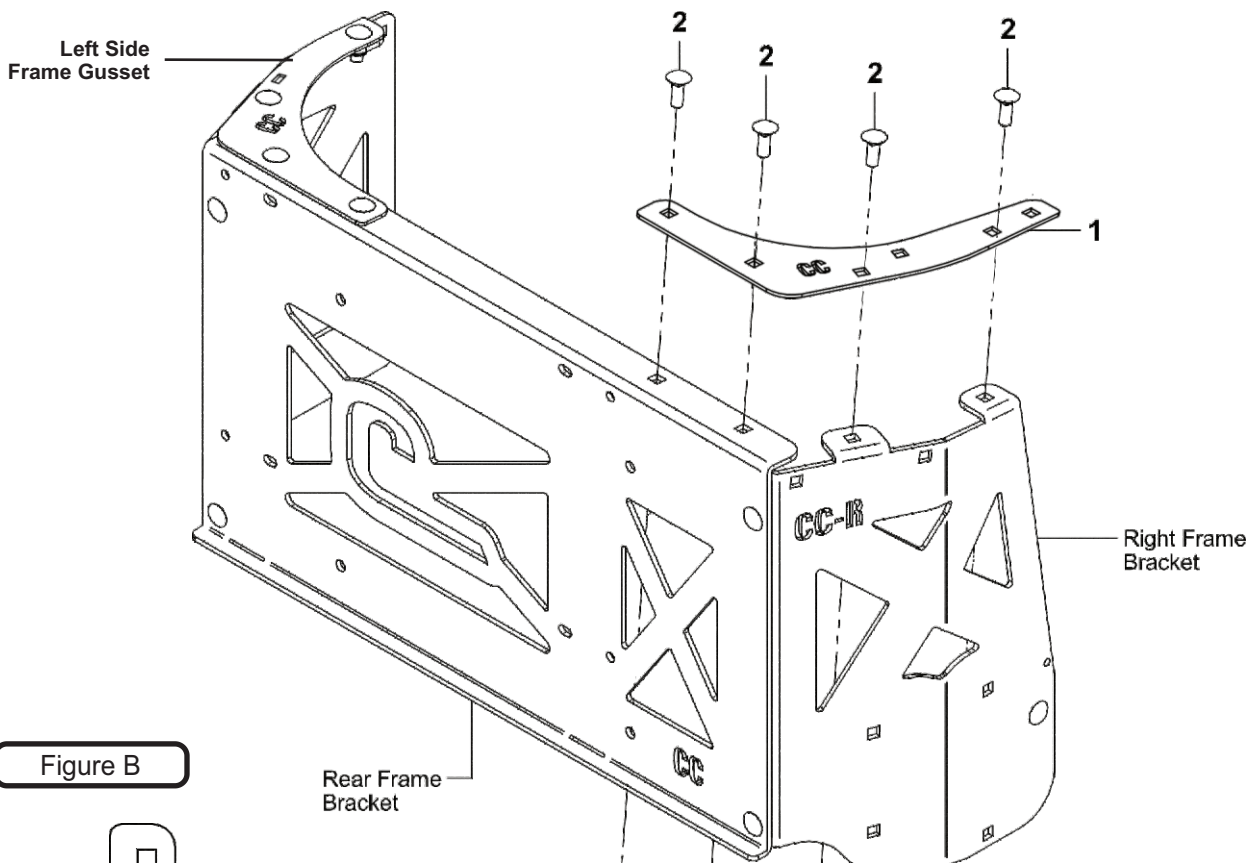
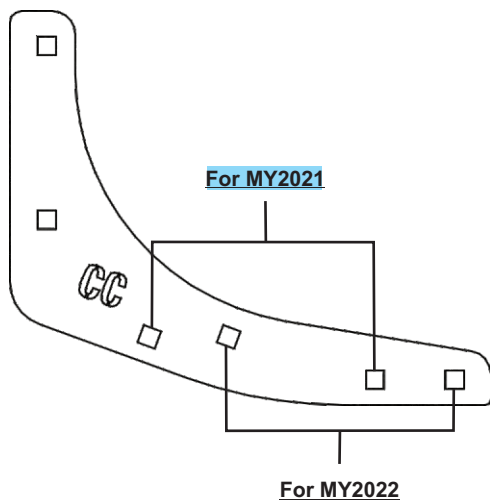

Figure B



Frame Gusset Installation (Cont.)

MY2022

Your Frame Gussets (Item #1) will have (2) different sets of bolt holes for your specific Mower model, see Figure B.

To install the Frame Gusset (Item #1) on the right side, align and position the mount holes of the Frame Gusset over the mount holes located on the top right of the Rear Frame Bracket and the top of the Right Frame Bracket. Secure the Frame Gusset, relatively loosely, by using (4) 3/8"-16 x 1" Carriage Bolt (Item #2), (2) 3/8" Flat Washers (Item #3) and (4) 3/8"-16 Ny-Flange Lock Nuts (Item #4). Refer Figure A below.

Repeat the same procedures to install the left side Frame Gusset. Once installed, tighten at this time.

Note: Some parts and part features have been hidden from view for visual clarity.

Figure A

Item #	Part #	Desc.	Qty.
1	B2081	Frame Gusset	2
2	K1182	Carriage Bolt 3/8"-16 x 1"	4
3	K1477	Flat Washer / 3/8" / .406 ID x .812 OD x .125 Thk	4
4	K2038	Ny-Flange Lock Nut 3/8"-16	4

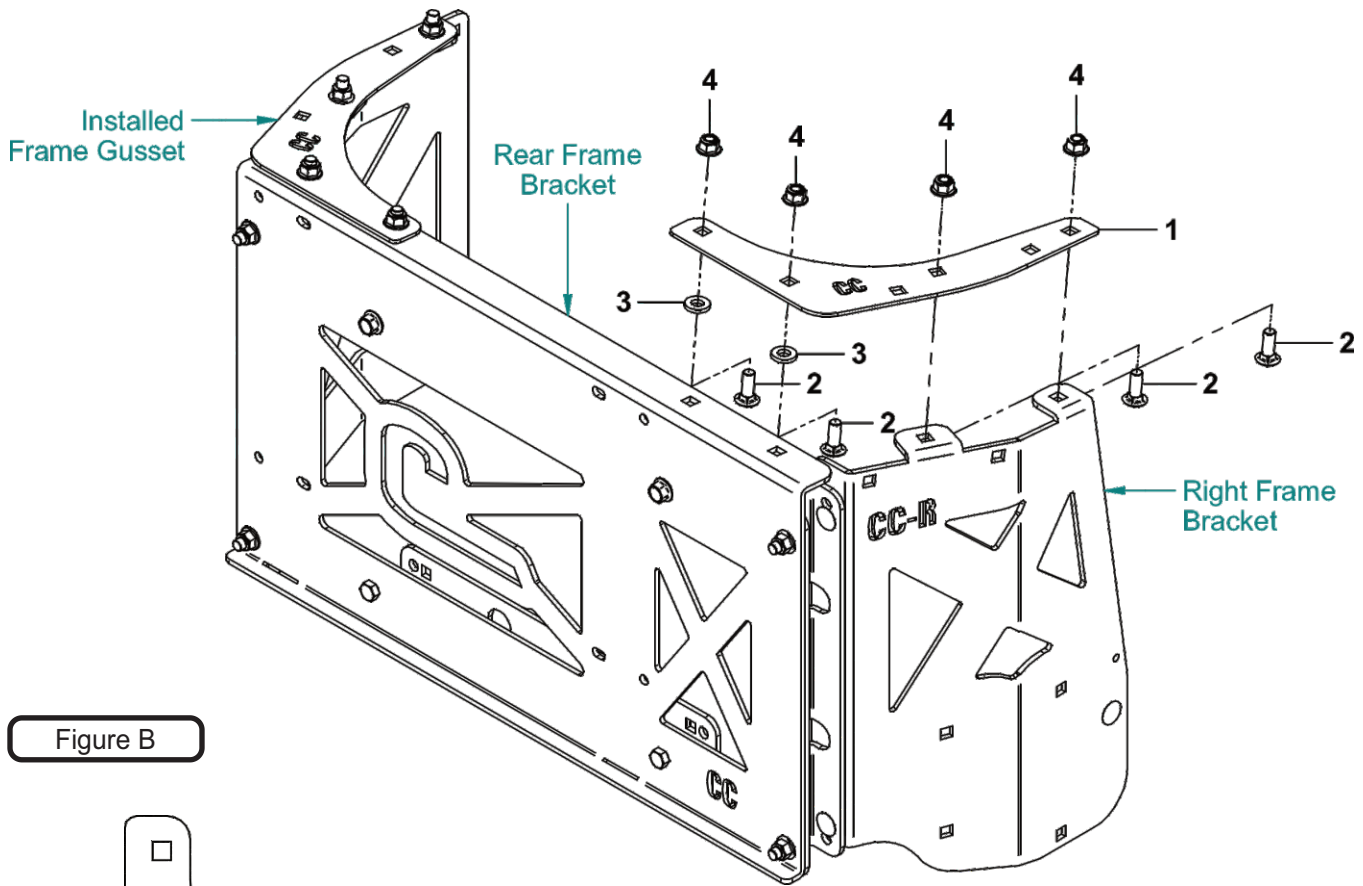
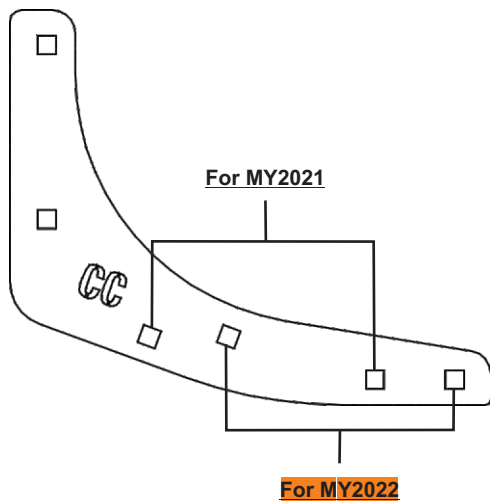

Figure B



Mount Arm / Top Bracket Installation

To install the Mount Arm / Top Bracket (Item #1) align the bolt holes to those on Right Frame Bracket. Secure the Mount Arm / Top Bracket, relatively loose, by using (2) 3/8"-16 x 1" Carriage Bolts (Item #2) and (2) 3/8"-16 Ny-Flange Lock Nuts (Item #3). Refer to Figure A.

Keep the hardware relatively loose until after the installation of the Mount Arm / Gusset.

Note: Some parts and part features have been hidden from view for visual clarity.

Figure A

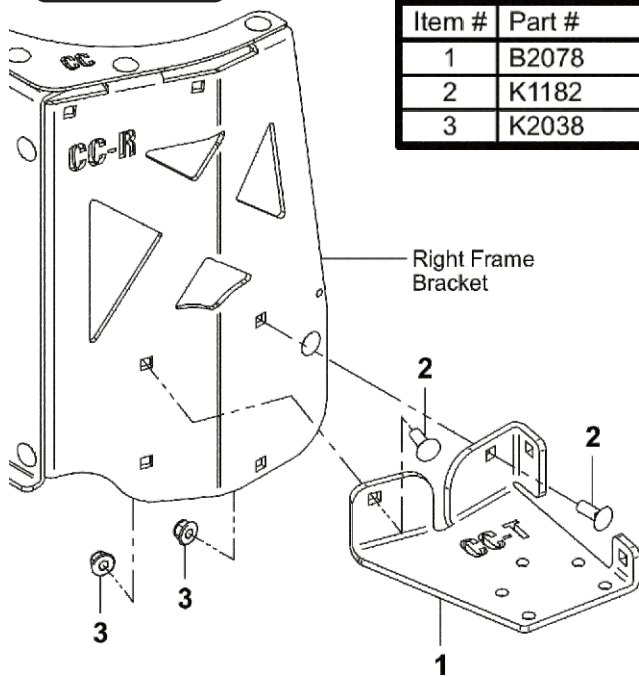

Item #	Part #	Desc.	Qty.
1	B2078	Mount Arm / Top Brkt.	1
2	K1182	Carriage Bolt 3/8"-16 x 1"	2
3	K2038	Ny-Flange Lock Nut 3/8"-16	2

Mount Arm / Bottom Bracket Installation

To install the Mount Arm / Bottom Bracket (Item #1) align the bolt holes to those on Right Frame Bracket. Secure the Mount Arm / Bottom Bracket, relatively loose, by using (2) 3/8"-16 x 1" Carriage Bolts (Item #2) and (2) 3/8"-16 Ny-Flange Lock Nuts (Item #3). Refer to Figure B.

Keep the hardware relatively loose until after the installation of the Mount Arm / Gusset.

Note: Some parts and part features have been hidden from view for visual clarity.

Figure B

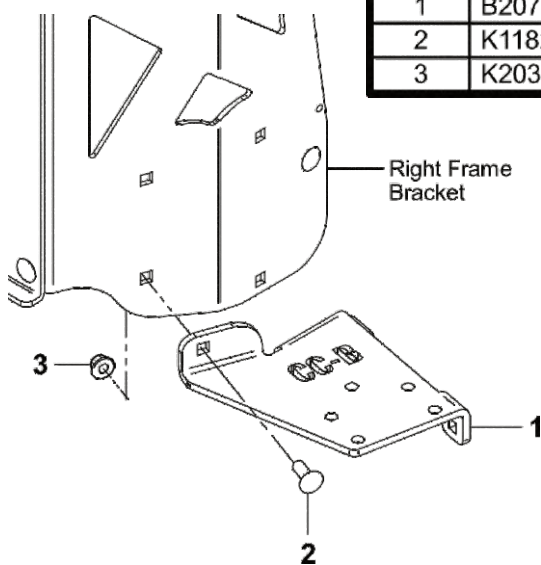

Item #	Part #	Desc.	Qty.
1	B2079	Mount Arm / Bottom Brkt.	1
2	K1182	Carriage Bolt 3/8"-16 x 1"	2
3	K2038	Ny-Flange Lock Nut 3/8"-16	2

Lower Side View

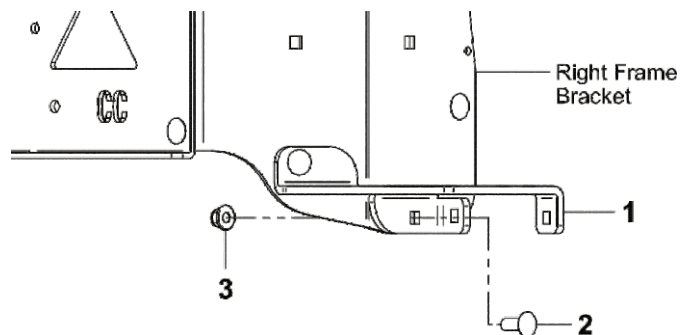

Mount Arm / Gusset Installation

After the installation of the Top (Item #4) and Bottom (Item #5) Mount Arm Brackets align the Mount Arm / Gusset (Item #1) mount holes to those located on the side of both Top and Bottom Mount Arm Brackets, refer to Figure B. Secure the Mount Arm / Gusset by using (4) 3/8"-16 x 1" Carriage Bolts (Item #2) and (4) 3/8"-16 Ny-Flange Lock Nuts (Item #3). Refer to Figure A.

Tighten all hardware at this time.

Note: Some parts and part features have been hidden from view for visual clarity.

Figure A

Item #	Part #	Desc.	Qty.
1	B2080	Mount Arm / Gusset	1
2	K1182	Carriage Bolt 3/8"-16 x 1"	4
3	K2038	Ny-Flange Lock Nut 3/8"-16	4
4	B2078	Mount Arm / Top Brkt.	1
5	B2079	Mount Arm / Bottom Brkt.	1

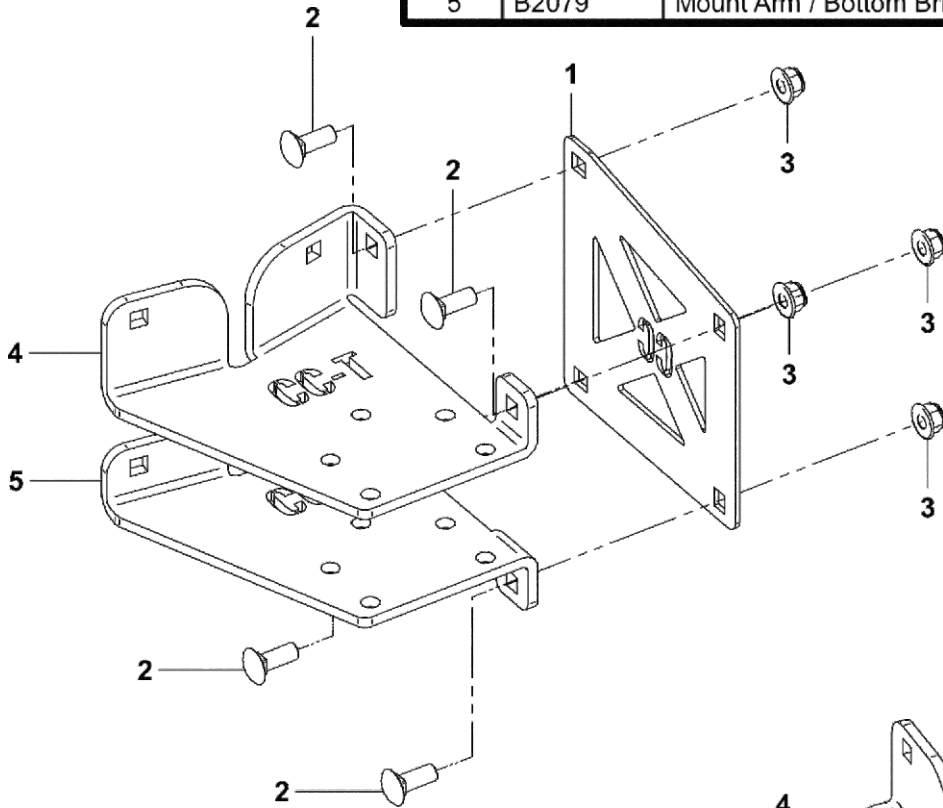
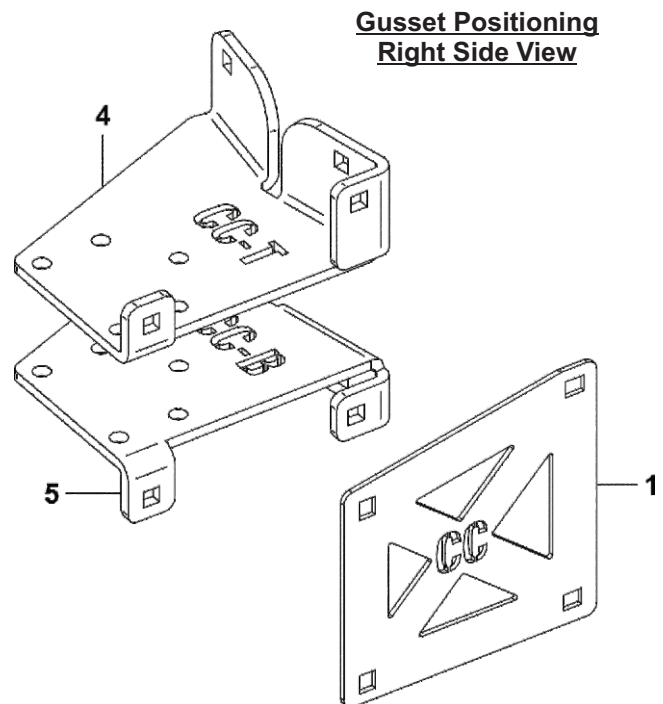

Figure B



Mount Arm / Tube Assembly Installation

First, use (1) 3/8"-16 x 3-1/2" HHCS (Item #2) and (1) 3/8"-16 Ny-Flange Lock Nut (Item #3) to install a stop bolt between both the Top / Mount Arm (Item #4) and Bottom / Mount Arm (Item #5). See Figure A. This will help with the installation of the Mount Arm / Receiver Tube Assy (Item #1).

Insert the Receiver Tube Assy (Item #1) in between the Top & Bottom Mount Arms using the Stop Bolt previously installed as a stopping point. Position the Receiver Tube between the (2) sets of bolt holes on the left and right side. Secure the Receiver Tube Assy by using (4) 3/8"-16 x 3-1/2" HHCS (Item #2) and (4) 3/8"-16 Ny-Flange Lock Nuts (Item #3), refer to Figure B.

Note: Some parts and part features have been hidden from view for visual clarity.

Figure A

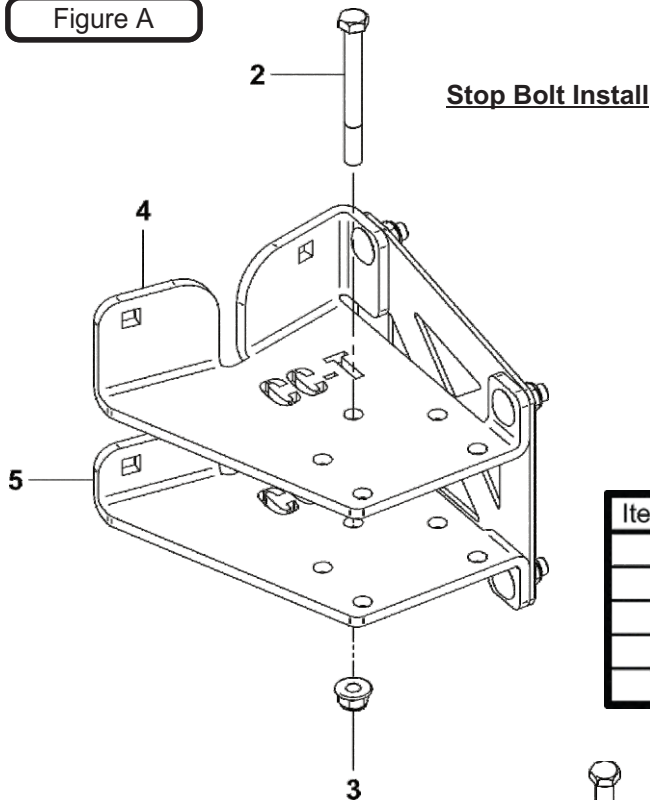

Item #	Part #	Desc.	Qty.
1	A2207	Receiver Tube Assy. / Mount Arm	1
2	K1200	3/8"-16 x 3.5" HHCS G5	4
3	K2038	Ny-Flange Lock Nut 3/8"-16	4
4	B2078	Mount Arm / Top Brkt.	1
5	B2079	Mount Arm / Bottom Brkt.	1

Figure B

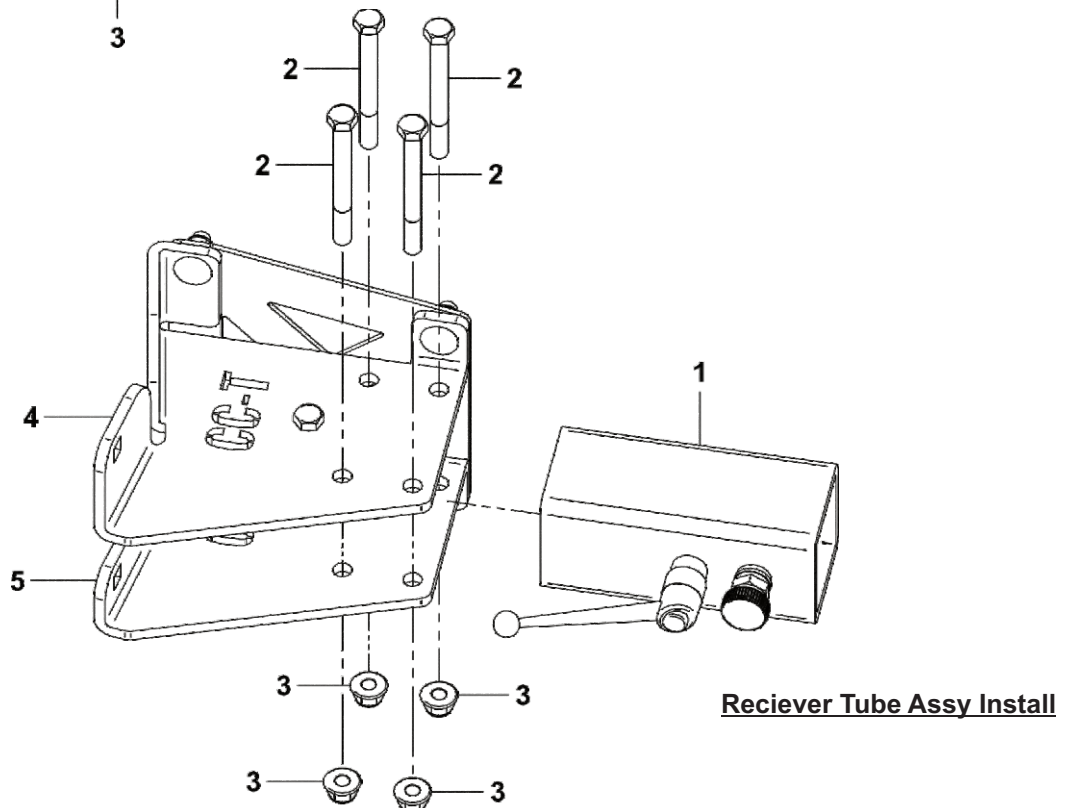

Main Frame Leg Installation

To Install the Right Main Frame Leg (Item #2), align the (2) lower bolt holes to those on the top Right Frame Bracket. Secure the Right Main Frame Leg by using (2) 3/8"-16 x 1" Carriage Bolts (Item #3) and (2) 3/8"-16 Ny-Flange Lock Nuts (Item #4). Leave the hardware relatively loose. Refer to Figure A.

Repeat the procedure to the Left Main Frame Leg (Item #1) onto the Left Frame Bracket.

Note: Some parts and part features have been hidden from view for visual clarity.

Figure A

Right Side View

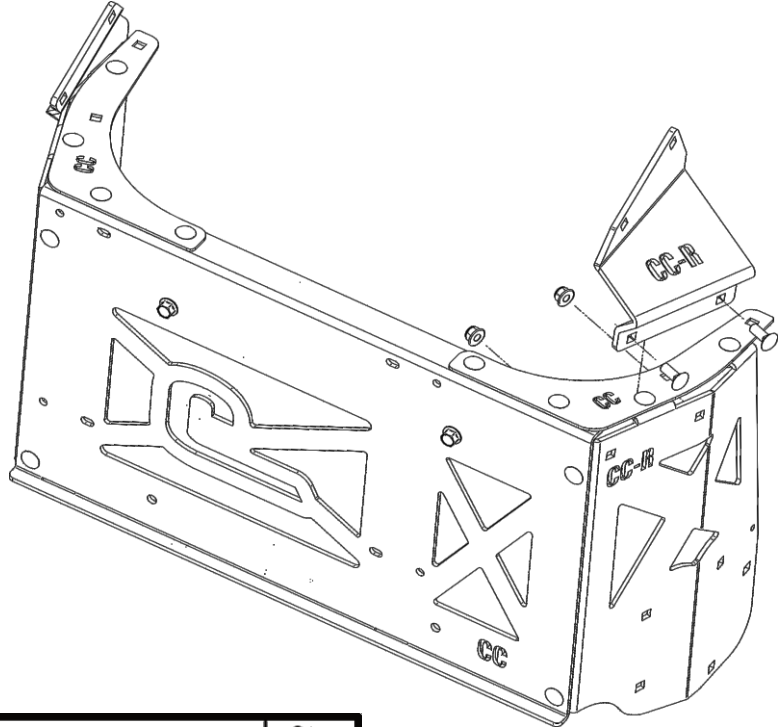

Item #	Part #	Desc.	Qty.
1	B2076	Lt. Main Frame Leg	1
2	B2077	Rt. Main Frame Leg	1
3	K1182	Carriage Bolt 3/8"-16 x 1"	2
4	K2038	Ny-Flange Lock Nut 3/8"-16	2

Figure B

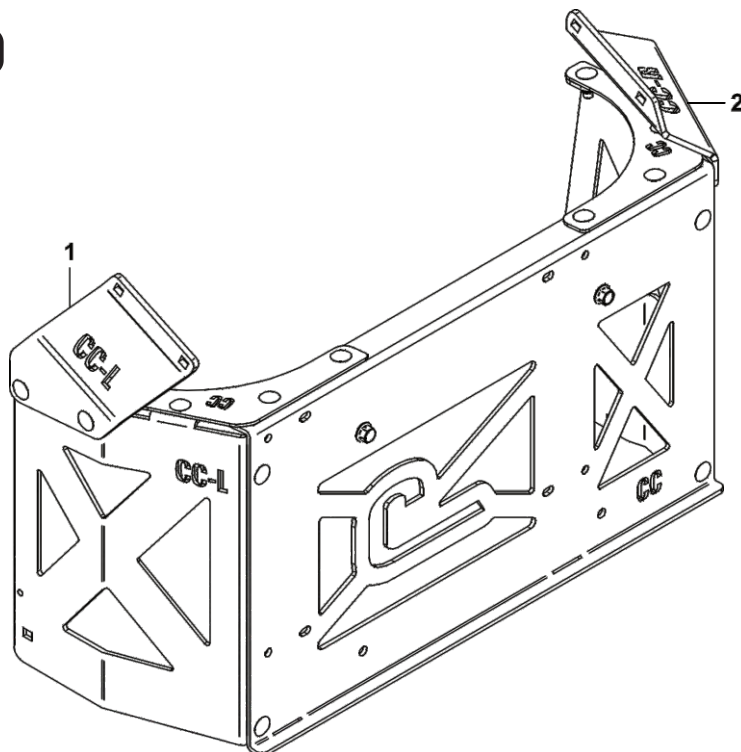

Left Side View

Main Frame Assembly Installation

It is recommended to have another person assist in the installation of the Main Frame Assembly (Item #1).

To install the Main Frame Assy (Item #1), position the Main Frame Assy so that both the Rt. Main Frame leg (Item #2) and the Lt. Main Frame leg (Item #3) is in between the Main Frame Assy, refer to Figure A.

Next, align the bolt holes of the Main Frame Assy to the Carriage Bolt holes of both the Main Frame Legs. Then secure the Main Frame Assy using (2) 3/8"-16 x 1" Carriage Bolts (Item #4) and (2) 3/8"-16 Ny-Flange Lock Nuts (Item #5) PER Leg. Refer to Figure B.

Note: Some parts and part features have been hidden from view for visual clarity.

Figure A

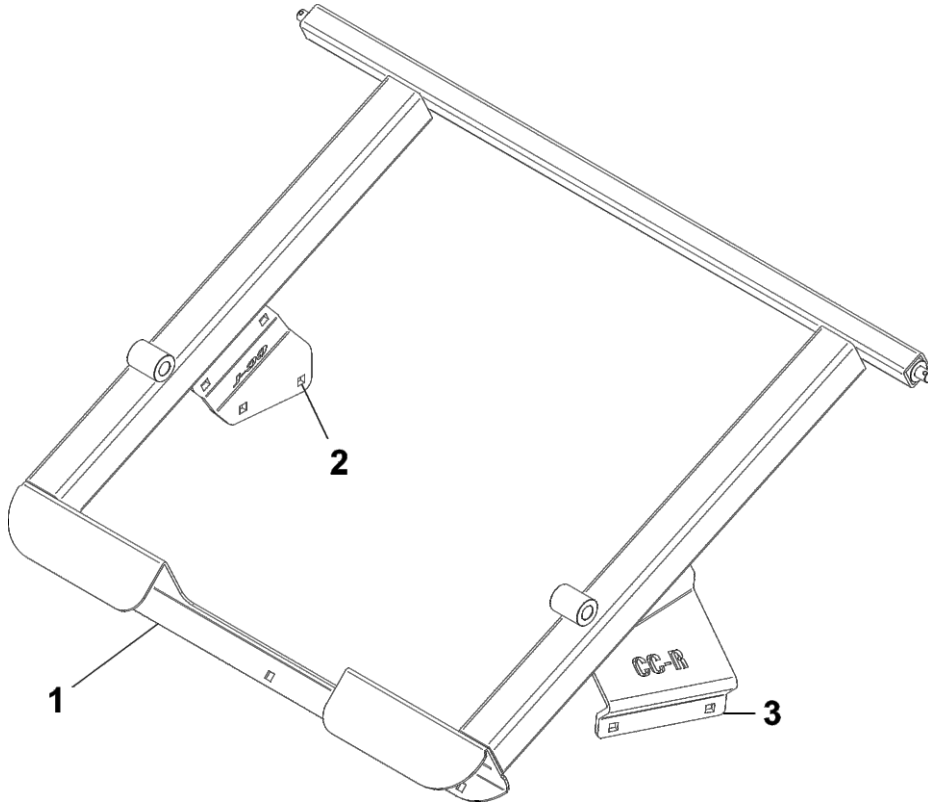
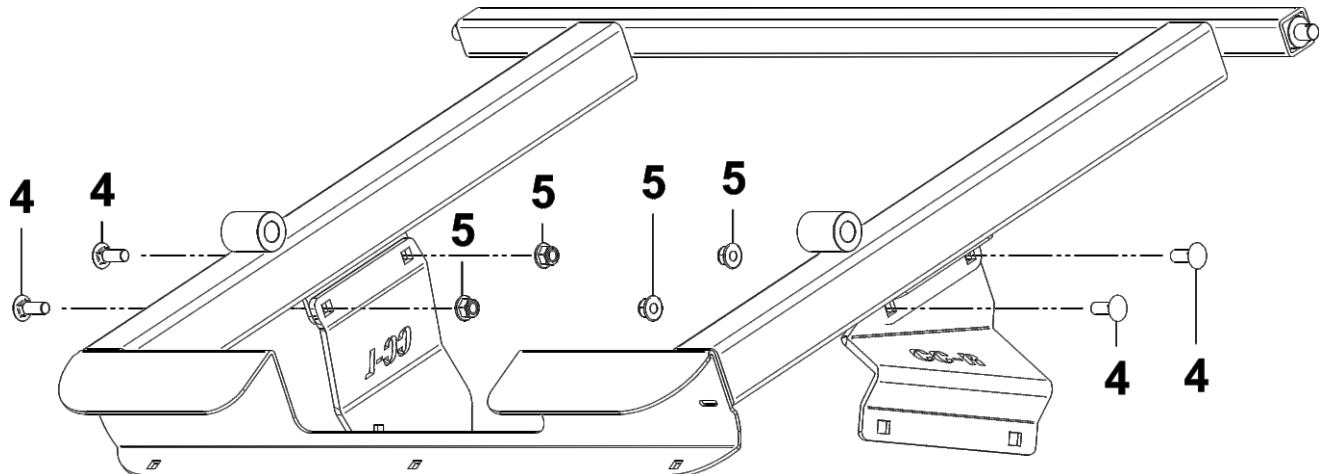

Figure B

Item #	Part #	Desc.	Qty.
1	A1192	Main Frame Assembly	1
2	B2077	Rt. Main Frame Leg	1
3	B2076	Lt. Main Frame Leg	1
4	K1182	Carriage Bolt 3/8"-16 x 1"	4
5	K2038	Ny-Flange Lock Nut 3/8"-16	4



PTO Drive Assembly

Once the Mount Arm Assembly is installed and secured to the mower, assemble the Drive Assembly P#(A2061_02), Belt Guard Assembly P#(A2069_02) & Idler Mount Assembly P#(A2067_02).

First, attach the Belt Guard Assembly P#(A2069_02) to the Drive Assembly P#(A2061_02) using (2) 1/4"-20 x 5/8" Carriage Bolts P#(K1010) and (2) 1/4"-20 Ny-Flange Lock Nuts P#(K2014). Refer to Figure A. **Leave Bolts Loose.**

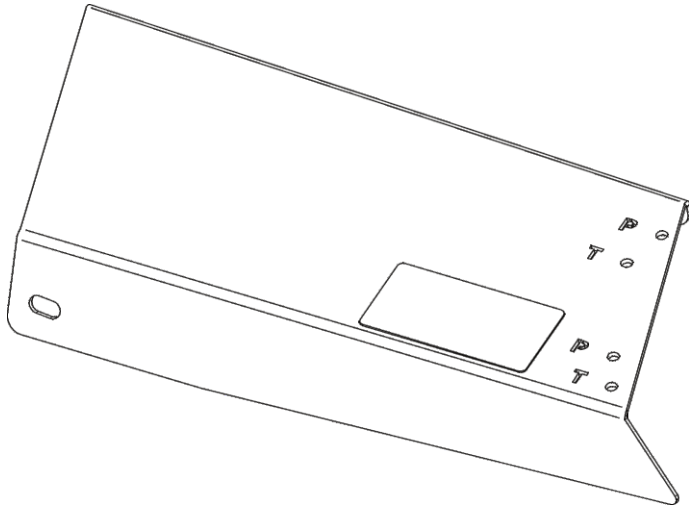

BELT GUARD ASSY. HOLES

Notice Marked Holes Below;
For This Installation, Use Holes
Marked With The Letter 'P'

Figure A

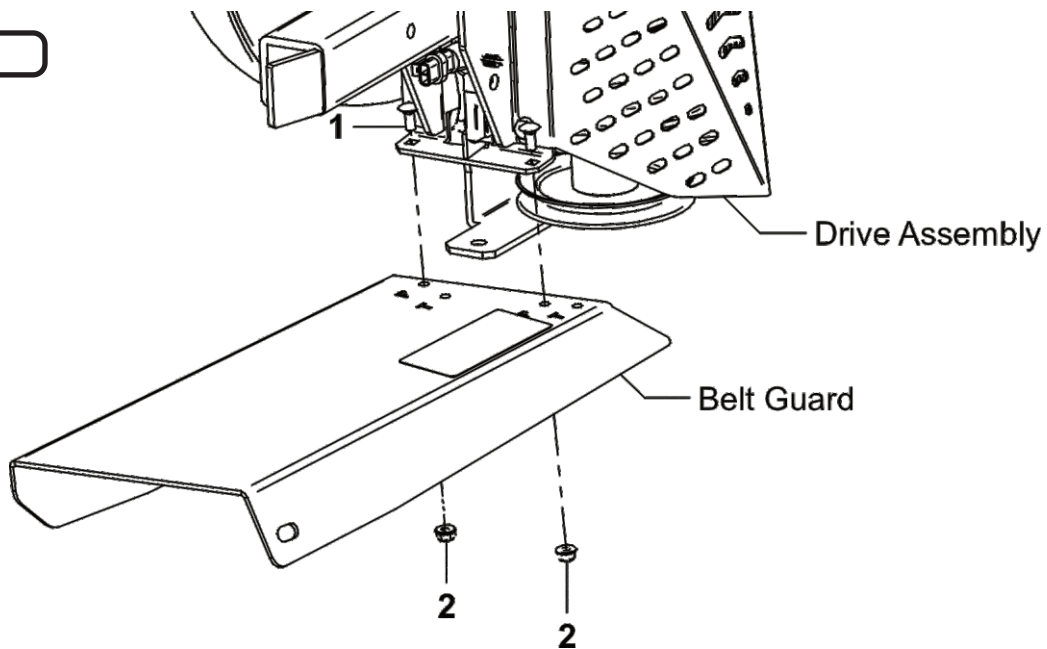

Item #	Part #	Desc.	Qty.
1	K1010	1/4"-20 x 5/8" Carriage Bolt	2
2	K2014	1/4"-20 Ny-Flange Lock Nut	2

PTO Drive Assembly (Continued)

Attach the Idler Mount Assembly P#(A2067_02) to the Drive Assembly using (1) 3/8"-16 x 1" HHCS (A) (Item #1), (1) 3/8"-16 x 1" Carriage Bolt (B) (Item #2) and (2) 3/8"-16 Ny-Flange Lock Nuts (Item #3). Refer to Figure B.

Leave Bolts Loose (Note: Orientation of bolts A & B.)

Next, secure the Idler Mount Assembly P#(A2067_02) to the Belt Guard Assembly P#(A2069_02) using (2) 3/8"-16 x 1" Carriage Bolts (Item #2) and (2) 3/8"-16 Ny-Flange Lock Nuts (Item #3). Refer to Figures C & D. Tighten All Bolts.

Figure B

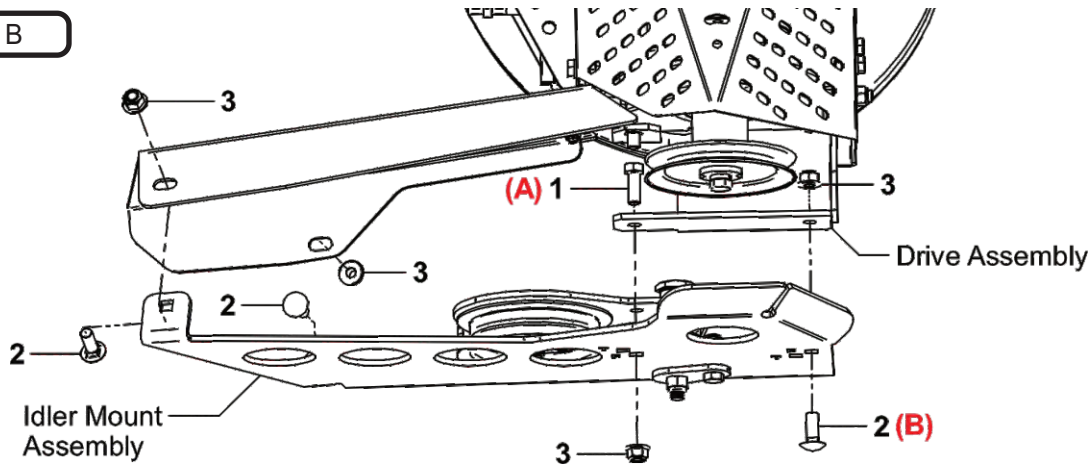

Item #	Part #	Desc.	Qty.
1	K1191	HHCS 3/8"-16 x 1" GR5	1
2	K1182	Carriage Bolt 3/8"-16 x 1"	3
3	K2038	Ny-Flange Lock Nut 3/8"-16	4

Figure C

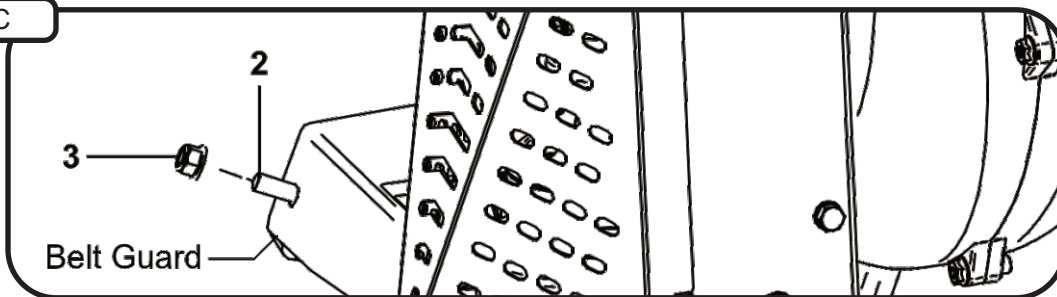
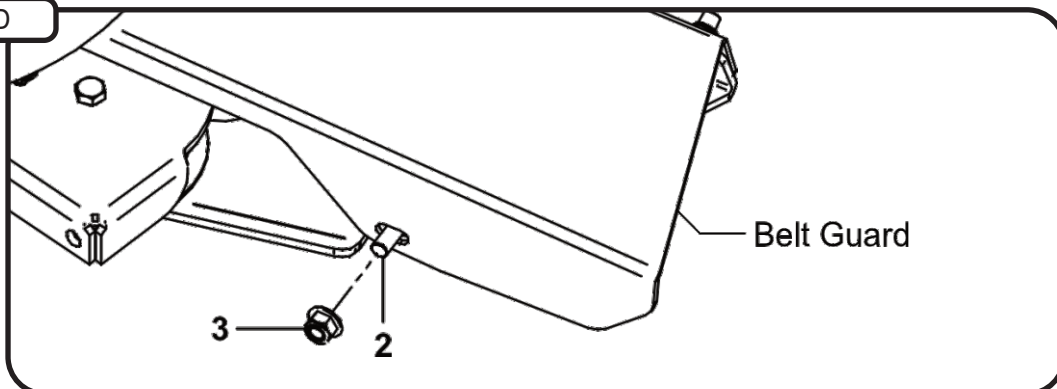

Figure D



Drive Assembly and Belt Installation

Note: It is recommended that someone assist during this step.

Insert the Drive Assembly into the receiver tube on the Mount Arm Assembly until the Knob Plunger Pin engages. Once in place, turn Lock Handle clockwise until tight. Next, feed the AK81 Belt P#(M0316) between the Belt Guard and the Idler Mount Assembly. Place belt around the Engine Drive Pulley on the underside of the mower. While one person inserts a screw driver (or similar tool) into the Idler Mount Assembly and rotates lever arm clockwise, enough to relieve all tension from belt, place belt around the Drive Assembly Pulley. Once the belt is in position, carefully release the tension to tighten belt.

Refer to the images below.

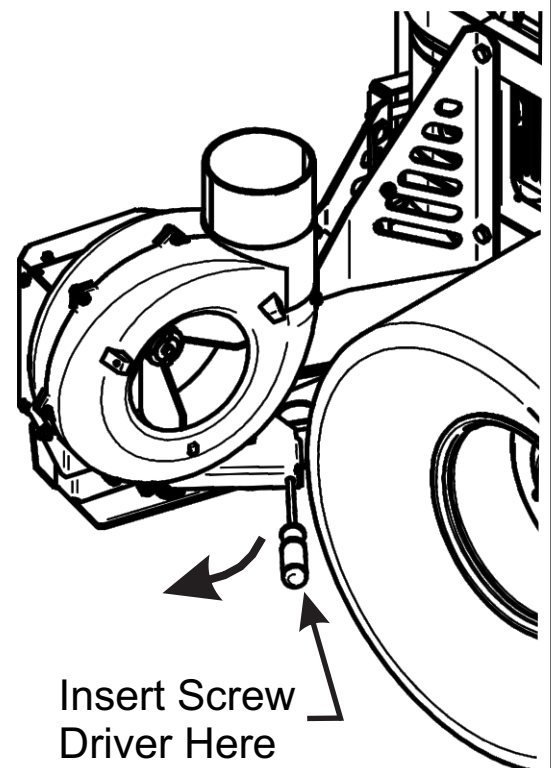
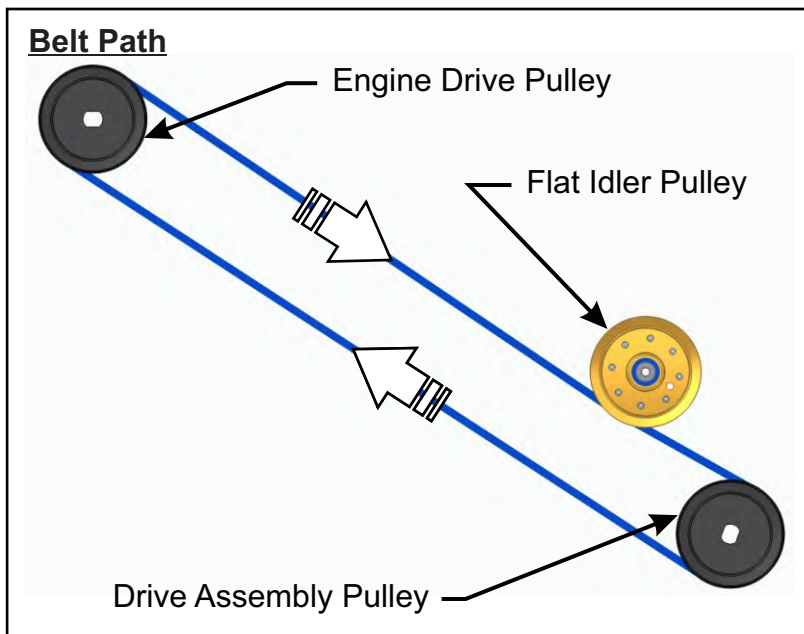
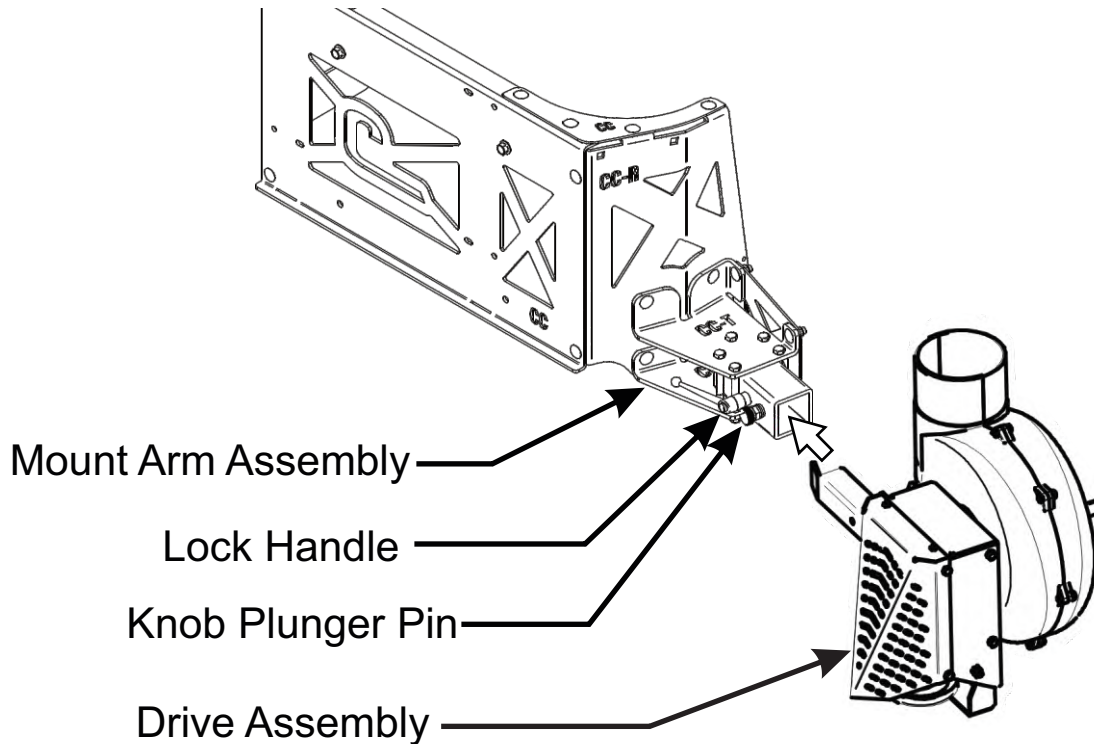

Belt Tension Adjustment

The following information provides you a step by step guide on how to position the PTO-X Drive to obtain proper belt tension before use. Failure to set proper belt tension can result in drive damage and frequent belt replacements.

In order to properly tension your belt you will need the following tools:

- Impact Wrench
- 9/16" Socket
- 9/16" Open-End Wrench
- 7/16" Open-End Wrench
- Gates Tension Gauge (See Figure A)
- Tape Measure
- Marking Pen

Figure A

Gates Tension Gauge



Step 1 - Remove the top belt guard from the drive assembly. See Figure B.

Figure B

Top Belt Guard

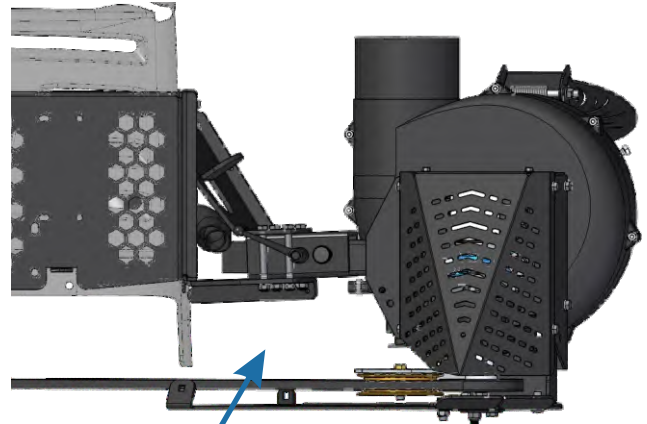
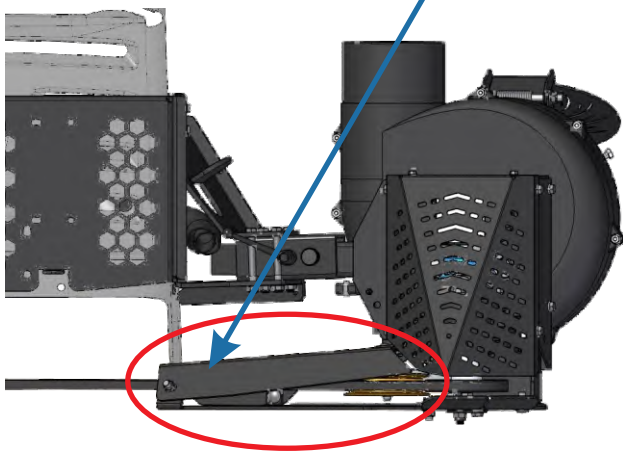

Belt Guard Removed

Step 2 - Using a measuring tape, measure from the pulley center to approximately 16" and lightly mark a line on the belt using a marking pen. See Figure C.

Figure C

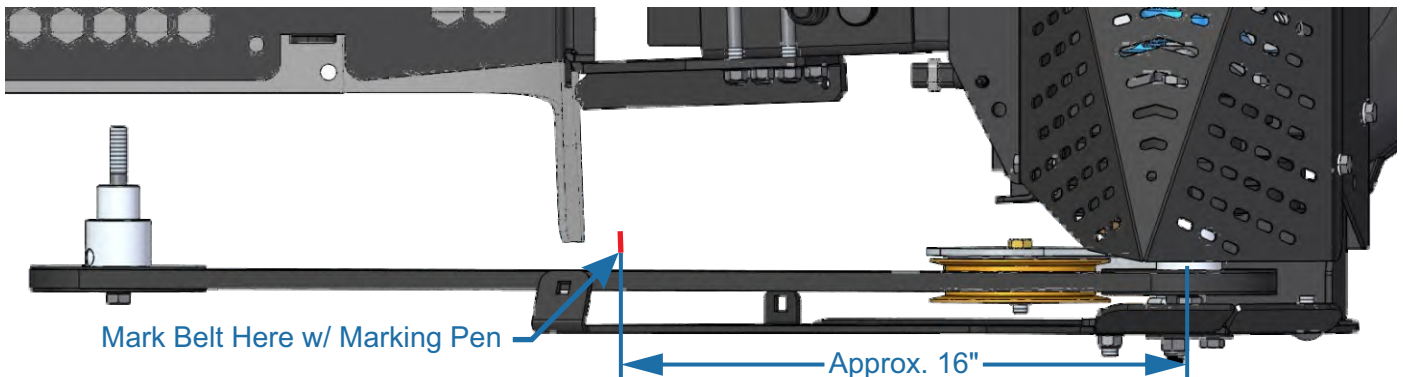

Belt Tension Adjustment (Cont.)

Step 3 - Place index finger into the loop on the Gates tension gauge. Position your finger over the line marked previously and keep the lower lip of the gauge below the belt. See Figure D.

Press inward until you feel a click. Remove the gauge and see the next step on how to determine the reading.

Figure D



Step 4 - To determine the tension, position the gauge at an angle to see where the edge of the blue dial intersects with the gauge markings. In Figure E below, the gauge is reading approximately 35 lbs. of tension.

The proper belt tension should measure between 35 lbs. minimum and 40 lbs. maximum. If your reading is within this range, you can replace the top belt guard and forego the next steps.

Figure E

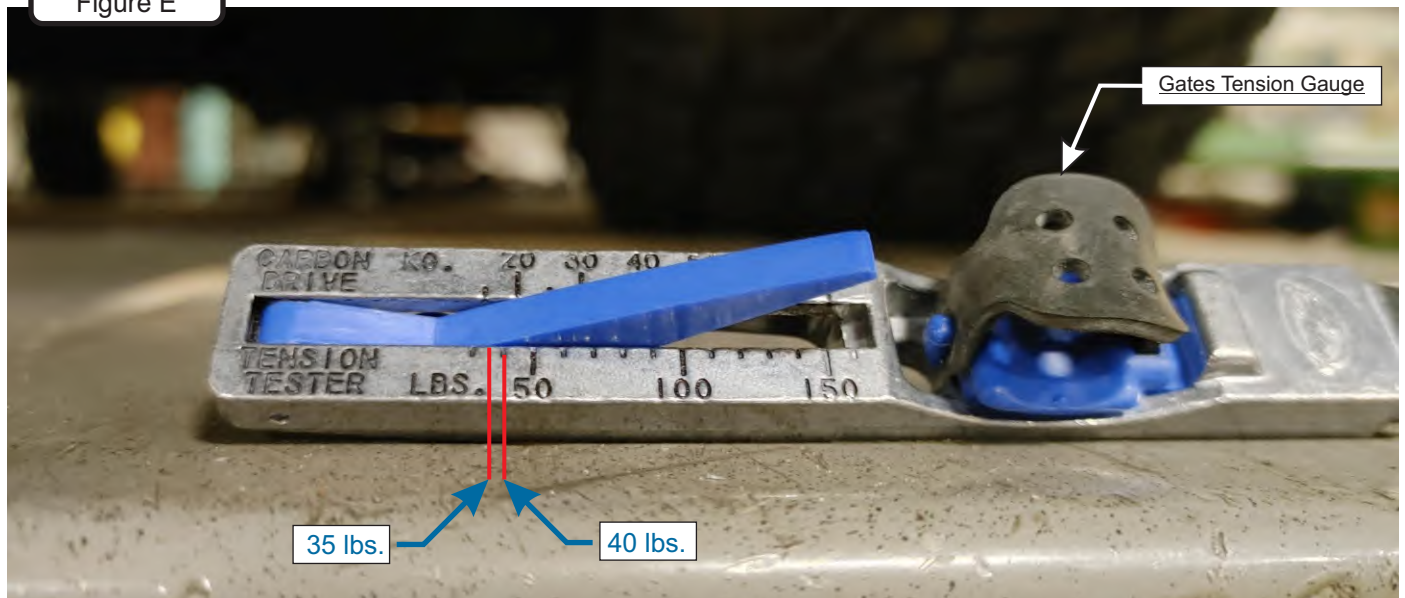

Belt Tension Adjustment (Cont.)

Step 5 - Belt Tension Procedure To Achieve 35-40 lbs. Tension

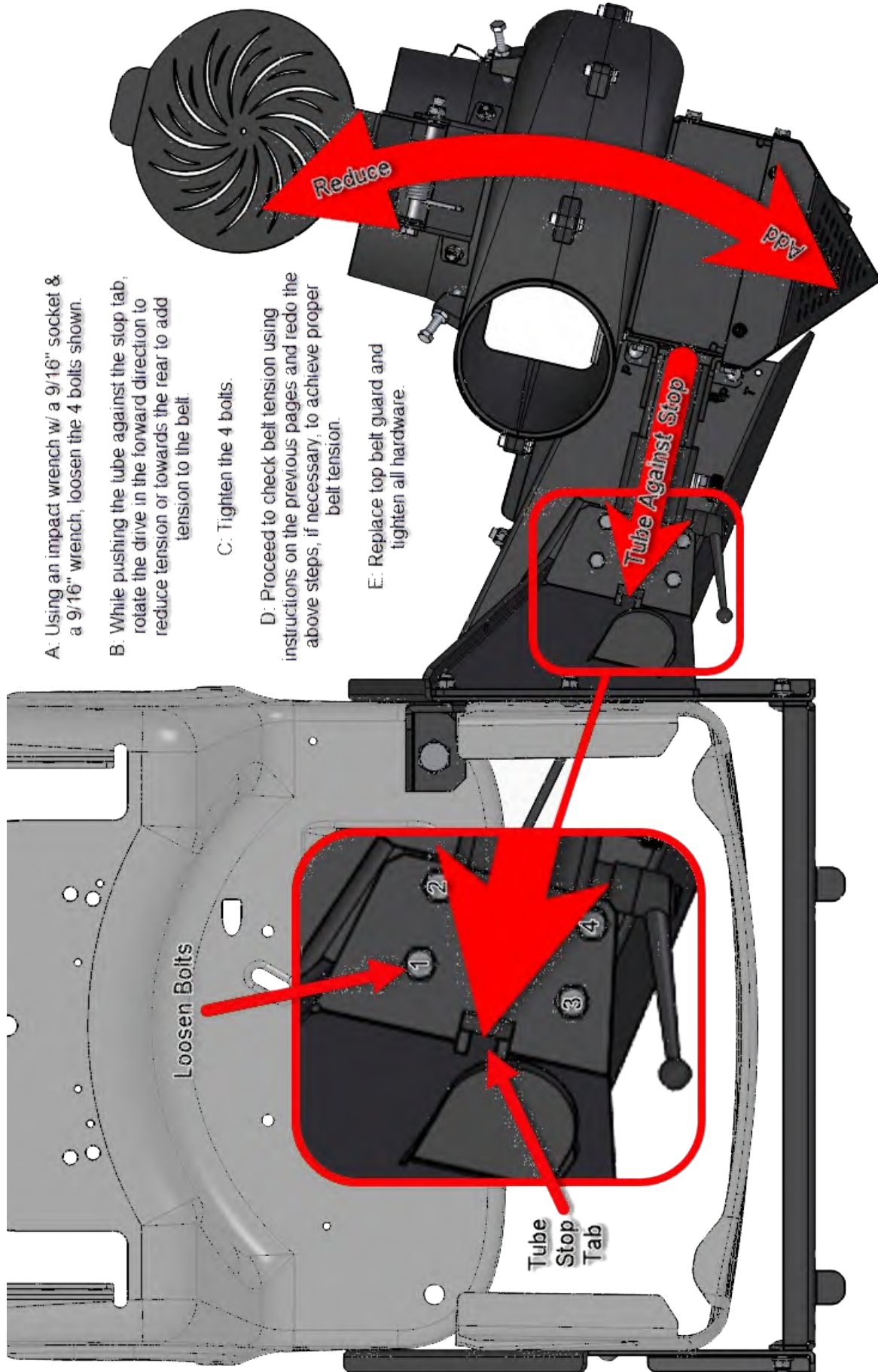

A: Using an impact wrench w/ a 9/16" socket & a 9/16" wrench, loosen the 4 bolts shown.

B: While pushing the tube against the stop tab, rotate the drive in the forward direction to reduce tension or towards the rear to add tension to the belt.

C: Tighten the 4 bolts.

D: Proceed to check belt tension using instructions on the previous pages and redo the above steps, if necessary, to achieve proper belt tension.

E: Replace top belt guard and tighten all hardware.

Loosen Bolts

Tube Stop Tab

Tube Against Stop

Reduce

Add

Lift Handle Installation

NOTE: Before continuing the Lift Handle installation, have someone assist you in turning the Box Assembly upside down. Insert (1) 3/8"-16 x 2" HHCS P#(K1208) into the Lift Handle P#(A0897), and secure with (1) 3/8"-16 Flange Nut P#(K1215). Thread the flange nut onto the bolt upside down, as shown in Figure A. Do not tighten the nut fully at this time.

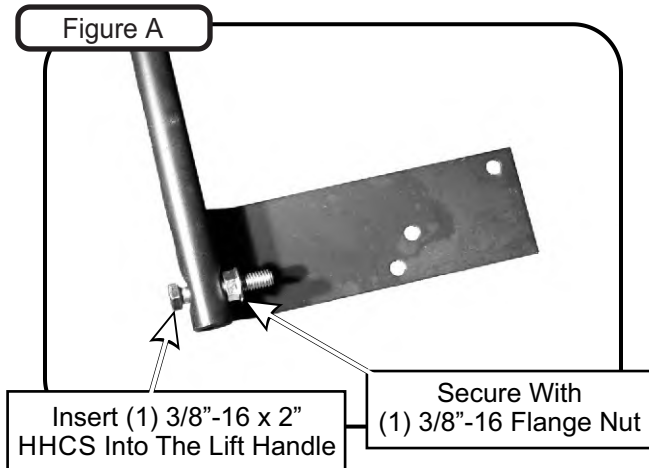

Slide the Lift Handle through the slot on the Handle Mount Bracket. Insert the Lift Handle into the Box Frame as shown in Figure B, and secure using (1) 3/8"-16 Flange Nut P#(K1215) on the inside of the Box as shown in Figure C. Now test the movement of the handle. It should have full-range of movement in the slot. If the handle does not have full-range of movement, adjust the 3/8"-16 Flange Nut from step A. Once achieved, tighten the fasteners.

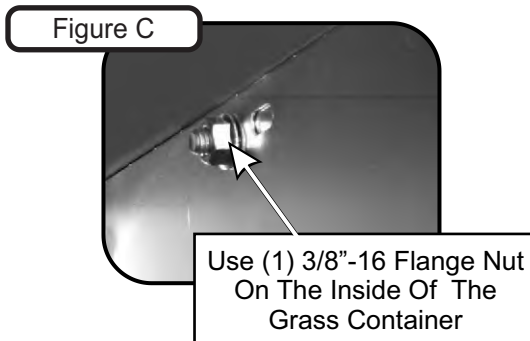
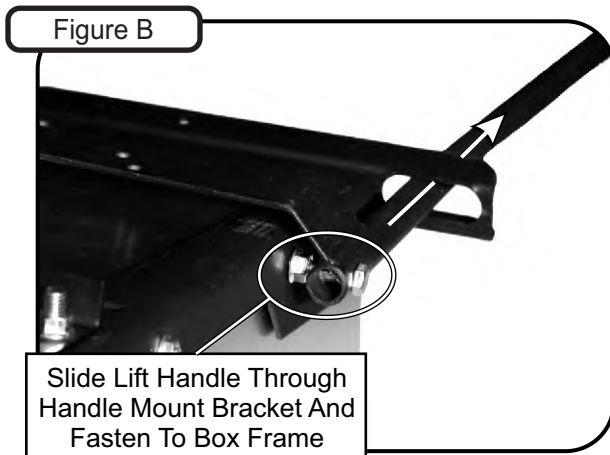

Fasten the Ball Joint P#(K1442) to the end of the Latch Rod P#(A2107). Thread (1) 5/16"-24 Hex Nut P#(K1444) all the way down onto the Latch Rod then tighten the Ball Joint to approximately half-way down the threads on the Latch Rod. Readjust the Hex Nut so it'll be right under the Ball Joint. Attach the Ball Joint to the Latch Hook as shown in Figure D, using (1) 5/16"-24 Hex Nut P#(K1444) and (1) 5/16" Lock Washer P#(K0043).

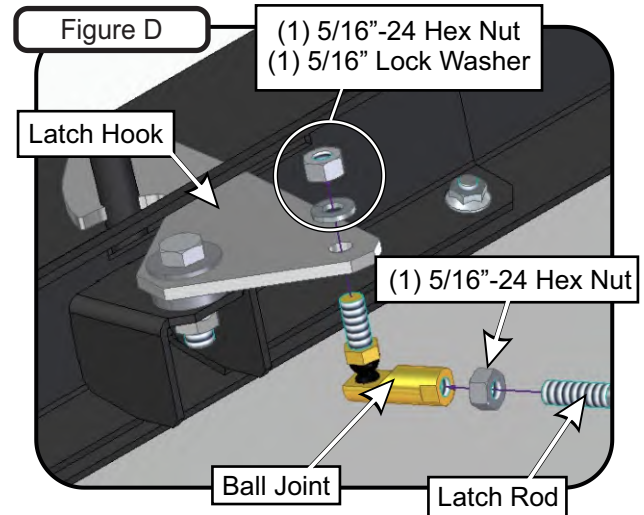

Attach the other end of the Latch Rod to the Lift Handle, as shown in Figure E. Attach one end of the Spring P#(J0176) to the Lift Handle and the other end of the Spring to the Handle Mount Bracket as shown in Figure F. Adjust the Ball Joint up or down on the Latch Rod threads until the Latch Hook closes completely. After adjusting the Latch Hook, secure the Latch Rod to the Lift Handle using (1) Cotter Pin P#(K0094).

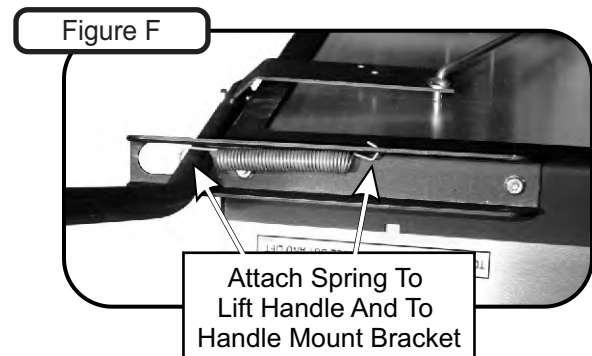
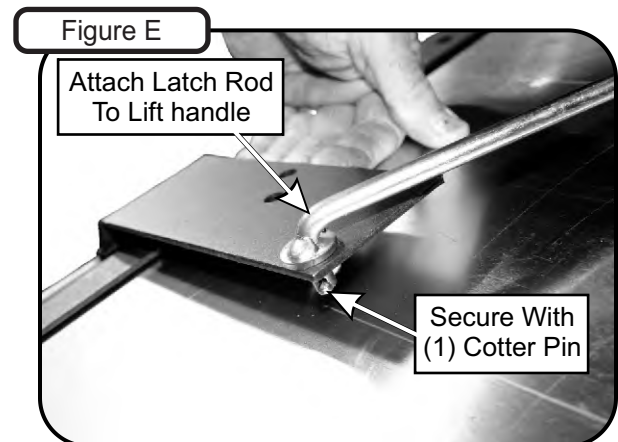

Aluminum Box Assembly Installation

NOTE: It is recommended that two extra people assist in mounting the Box Assembly.

Have two people lower the Box onto the frame while a third person inserts the Pivot Pins P#(K0172) through the pivot holes. Insert the Pins from the outside to the inside.

Secure with (1) 5/8" Washer P#(K0058) and (1) 5/32" x 2-5/8" Hair Pin Clip P#(K0088) per Pivot Pin (Figure B).

Reattach the bottom ends of the door opening linkages to the Main Frame by using (1) Rue-Ring Cotter Pin P#(K1437) per side.

To test the functionality of the dump mechanism, pull the Lift Handle away from the unit, and lift upward. The Door of the Box Assembly should open and the Box should pivot clockwise towards the ground.

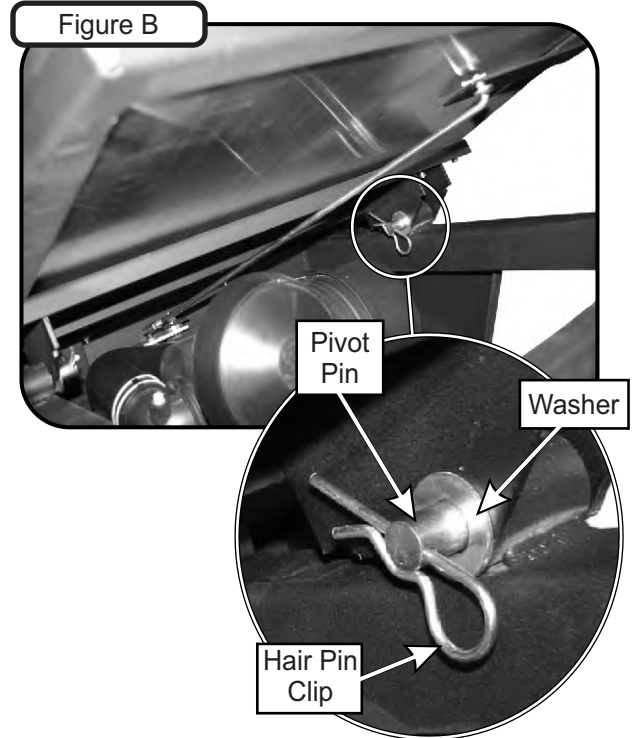
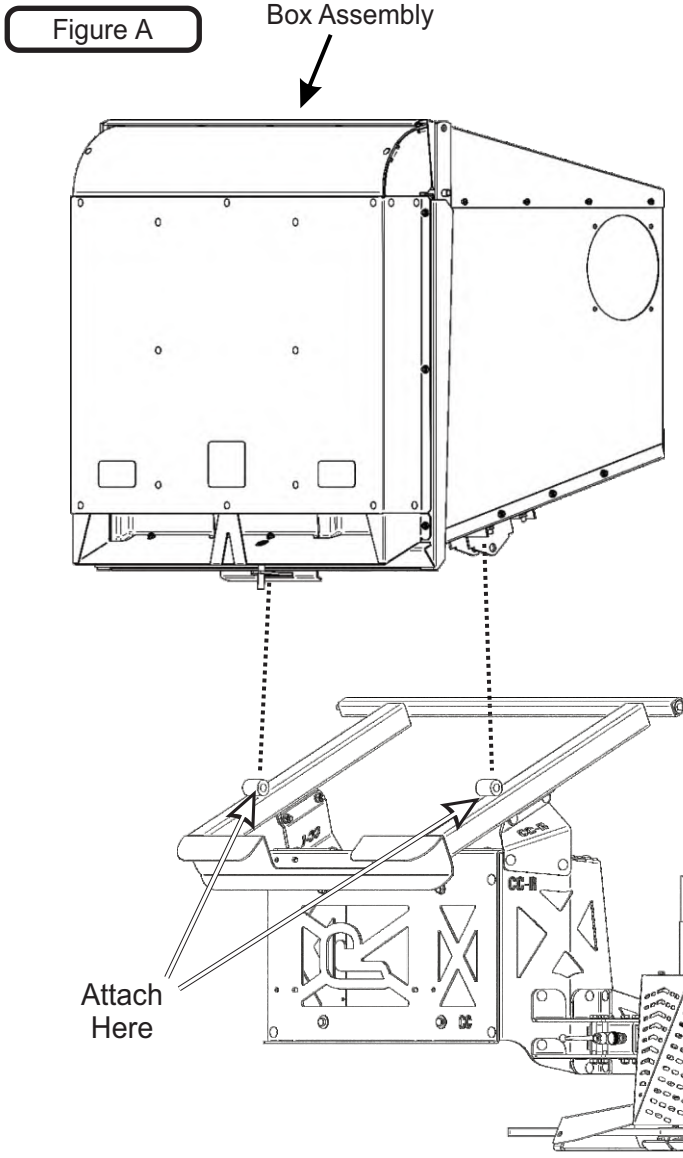

Dump Mechanism Adjustment

The Dumping Mechanism may be adjusted in three places, at the Adjusting Screw P#(K1435), at the Latch Hook Pivot Bolt and the linkage Ball Joint.

To change the door closure tightness, thread the Adjusting Screw (Figure C) in or out or by adjusting the Latch Hook Pivot Bolt within its' mounting slot.

To adjust the Latch Hook closure angle, thread the

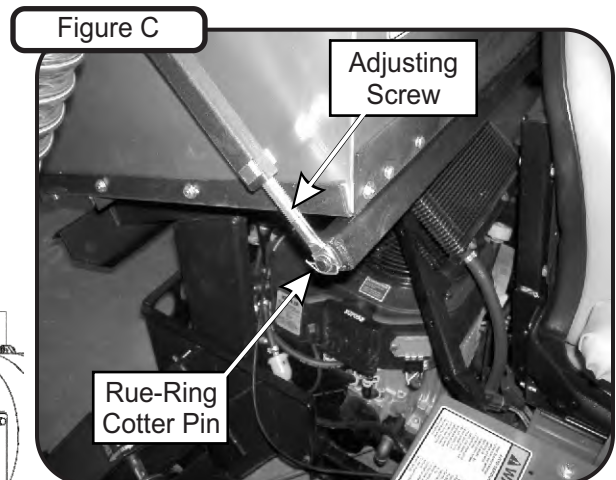

Inlet, Inlet Ring & Debris Deflector Installation

Open box door. From inside box, slide Inlet (Item #3) halfway into inlet hole (See Figure A). Take each half of the Inlet Ring (Item #1) and attach around matching groove in Inlet (Item #3). Slide Inlet (Item #3) & Inlet Ring (Item #1) against inlet hole and align four holes. Fasten Inlet Ring (Item #1) bottom holes using (2) 5/16" IT Tooth Lock Washers (Item #4) & (2) 5/16"-18 x 1/2" HHCS (Item #6) (See Figure B). Fasten Inlet Ring (Item #1) top holes using (2) 5/16" IT Tooth Lock Washers (Item #4) & (2) 5/16"-18 x 1-1/4" HHCS (Item #5). Slide Debris Deflector (Item #2) over inside top bolt threads (Item #5). Fasten Debris Deflector (Item #3) using (2) 5/16"-18 Ny-Flange Lock Nuts (Item #7). Final assembly should resemble Figure C.

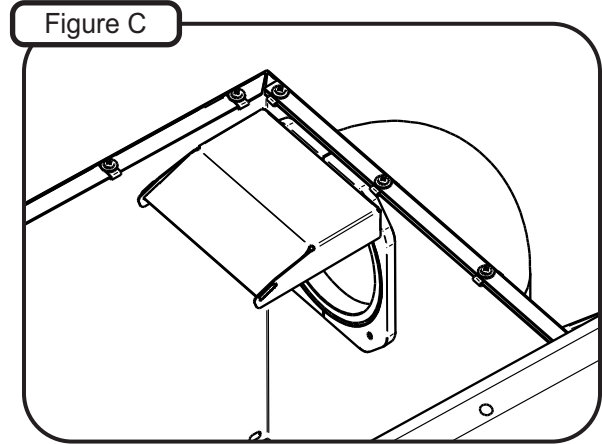
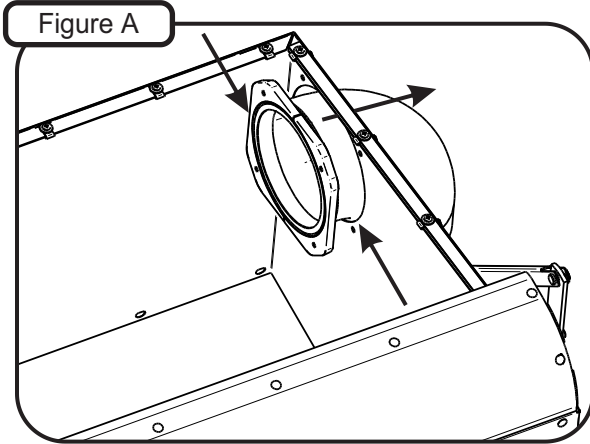
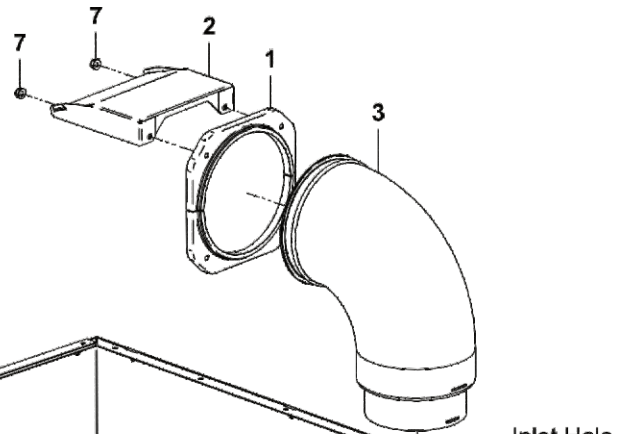
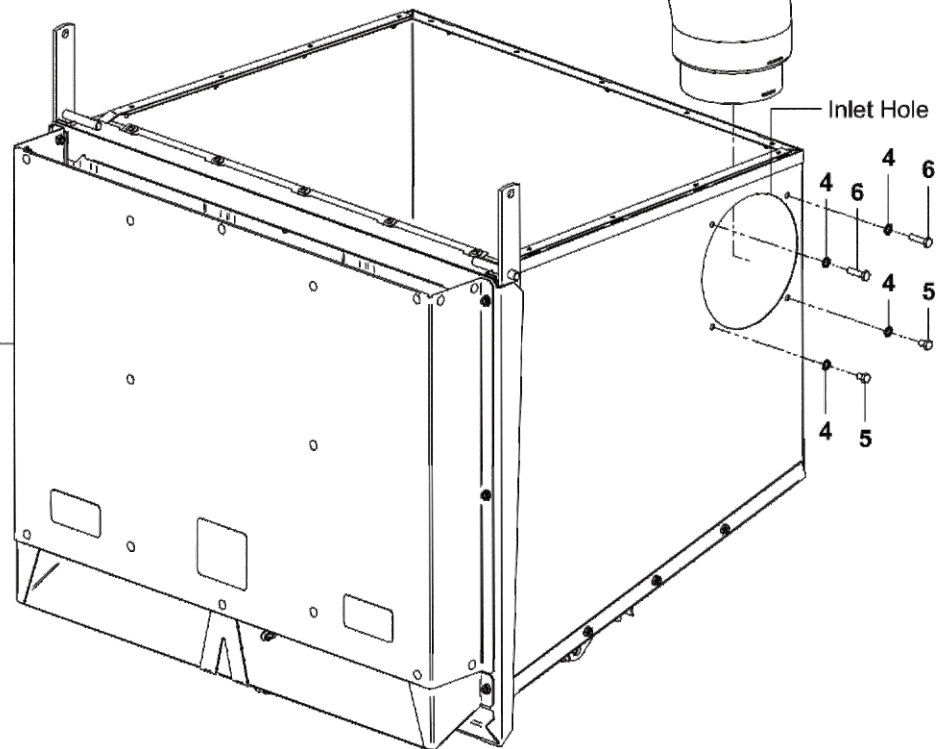

Figure B

Item #	Part #	Desc.	Qty.
1	C0074	Inlet Ring	1
2	C0088	Debris Deflector	1
3	V0025	Universal Inlet / 6" & 7"	1
4	K0044	I/T Tooth Lock Washer 5/16"	4
5	K1152	HHCS 5/16"-18 x 1/2"	2
6	K1156	5/16"-18 x 1-1/4" HHCS	2
7	K2516	Ny-Flange Lock Nut 5/16"-18	2



Open Box Door
to Install Inlet,
Inlet Ring &
Debris Deflector



Note: Box Top & Screen Removed
in Figure for visual clarity.

Boot Kit Assembly & Installation

Secure the Boot Plate (Item#2) to the Aluminum Boot (Item#1) using (2) 3/8"-16 x 1" Carriage Bolts (Item#3) and (2) 3/8"-16 Ny-Flange Lock Nuts (Item#4). Insert the Carriage Bolts from the inside of the Boot so the threads are on the top of the Boot. This will prevent grass clippings from collecting on the threads. Leave the hardware loose until the Boot Plate has been attached to the mower deck. Refer to Figure A.

Remove the hardware from the grass deflector and insert (1) Boot Rod (Item#5) into the grass deflector mounting holes as shown in Figure B. Secure the Boot Rod using (1) Hair Pin Clip (Item#6). With the Carriage Bolts still loose, adjust the position of the Boot so that there is no gap between the mower deck and the Boot. Tighten the hardware at this time.

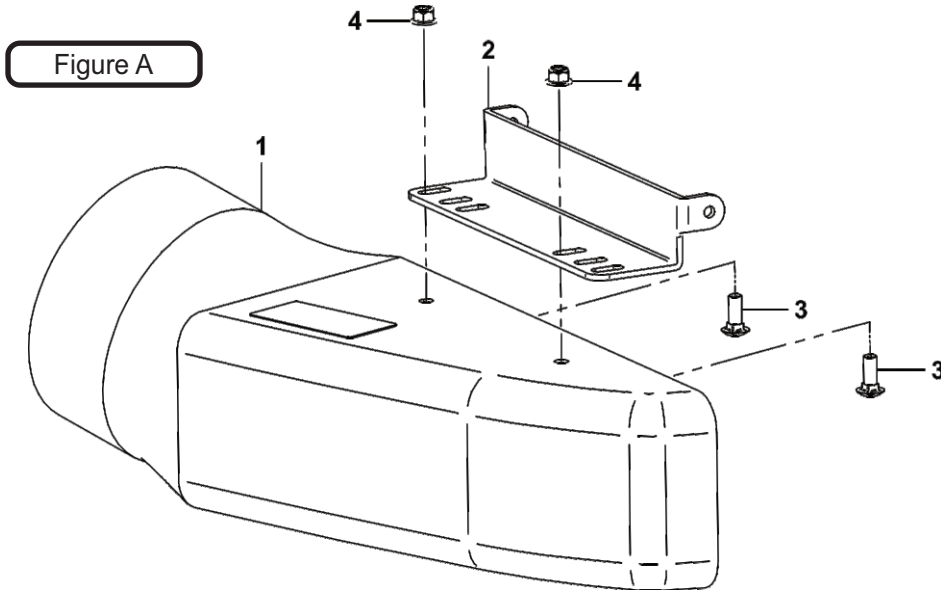

Item #	Part #	Desc.	Qty.
1	E0032A	Modified E0032	1
2	B0820	Boot Plate	1
3	K1182	Carriage Bolt 3/8"-16 x 1"	2
4	K2038	Ny-Flange Lock Nut 3/8"-16	2
5	B4331	Boot Rod	1
6	K0099	Hair Pin Clip 3/32"	1

Figure B

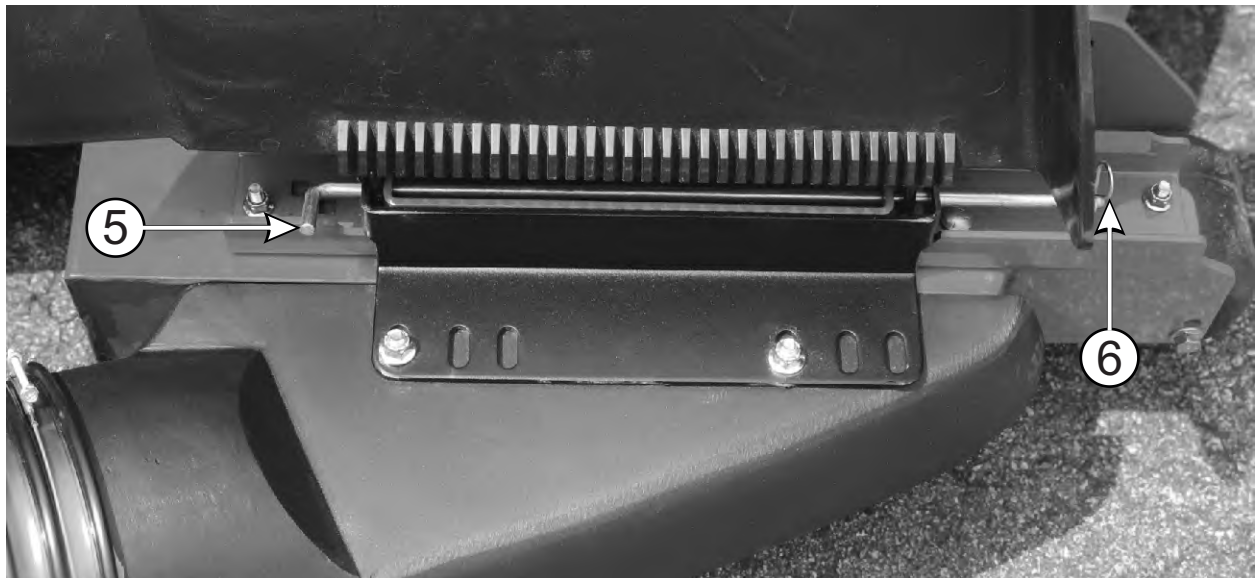

Blower Cone Installation

Thread (1) 5/16"-18 Jam Nut P#(K0120) onto each end of (2) 5/16"-18 x 2-1/2" HHCS P#(K0125) as shown in Figure B.

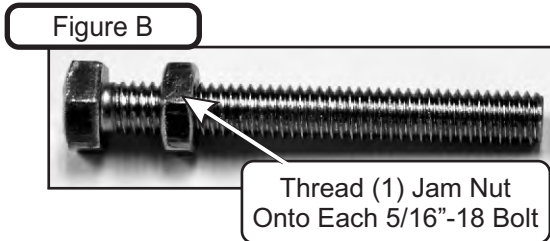

Now partially thread (1) bolt into each of the two threaded bosses located on the Blower Housing. Place 8" Blower Cone P#(E6009) so the two tabs line up with the bolts and tighten completely as shown in Figure C.

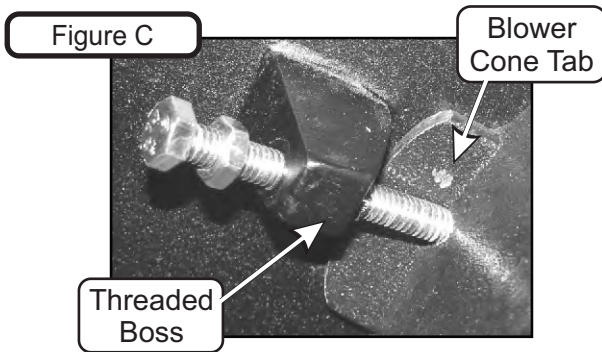

Once the (2) bolts are tight, tighten the Jam Nuts against the threaded boss as shown in Figure D.

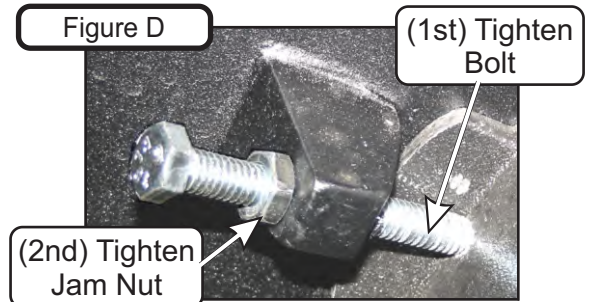

Refer to Figure E for proper Blower Cone installation reference.

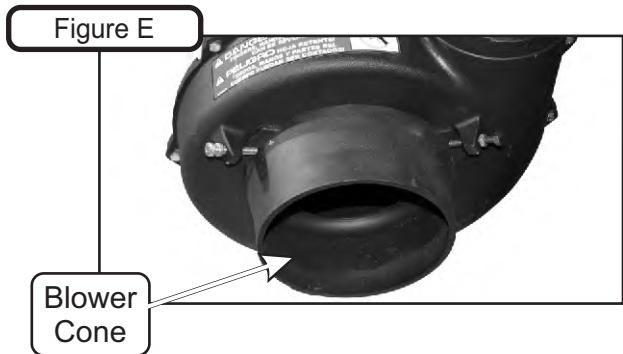

Length Of Hose Adjustment

The hoses in the following steps must be cut to fit your machine. Do not cut the hoses until you have tried to fit them on your machine. Remember that the hoses need to be long enough to allow for the opening and closing of the collection system as well as allowing ample clamping surface between each component.

Upper Hose Installation

Slide a Hose Clamp P#(J0060) over one end of the 6" Upper Hose. Secure this end of the 6" Upper Hose to the Blower Outlet. See Figure below for details. Secure opposite end of the 6" Upper Hose to the Inlet. Make sure both ends are securely fastened by tightening the Hose Clamp.

Lower Hose To Blower Cone Installation

Slide a 8" Hose Clamp P#(J0080) over both ends of the 8" Lower Hose. Secure one end of the Lower Hose to the Blower Cone and fasten by tightening the Hose Clamp.

Lower Hose To Boot Installation

Take the unattached end of the Lower Hose and secure it to the circular end of the Boot and fasten by tightening the Hose Clamp.

Tip: Before securing Hose Clamp fully, rotate Lower Hose counter-clockwise (away from yourself) approximately 1" to aid in retaining Boot to mower deck.

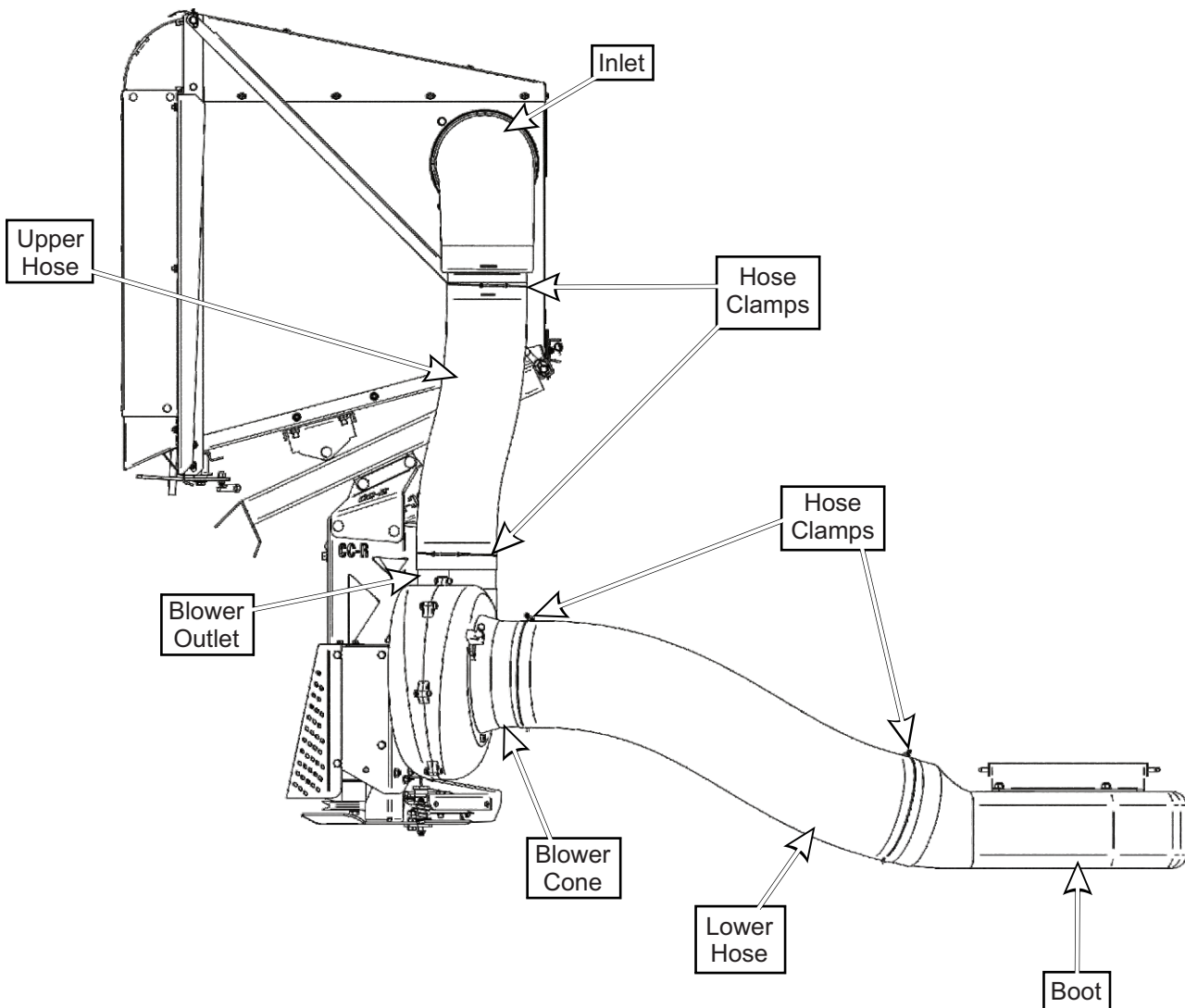

Wire Harness Installation



WARNING

**To Prevent Serious Injury-
Proper Installation Of Safety Interlock Harness
Is Mandatory. Please Check That All Interlock
Points Work Correctly Once Installed.**

Before installing the PTO Switch Plate, install the PTO Rocker Switch by positioning it over the Switch Plate and firmly pressing the Rocker Switch down until it is seated in place. Make sure the 'FAN' Symbol is positioned to the 'ON' side of the PTO Switch Plate. Refer to Figure A.

Once installed, connect the Wire Harness' (2) Female Switch Disconnects to the PTO Rocker Switch. Refer to Figure B for the Wire Harness components and Figure C on the next page for installation diagram.

To install the PTO Switch Plate , (#1) remove the corner hardware to the right of the operator's seat as shown in Figure A on the panel cover and set it aside. Next, Place the PTO Switch Plate over the mount hole on the panel cover aligning the slot with the corner mount hole. Secure the Switch Plate by using the previously removed hardware. Refer to Figure A below.

Next, route the (#2) Negative Lead (-) and the Positive Lead (+) of the Wire Harness to the negative & positive terminal of the mower's battery. Refer to Figure B for the Wire Harness components, refer to Figure C on the next page for the Wire Harness to mower connection.

Figure A

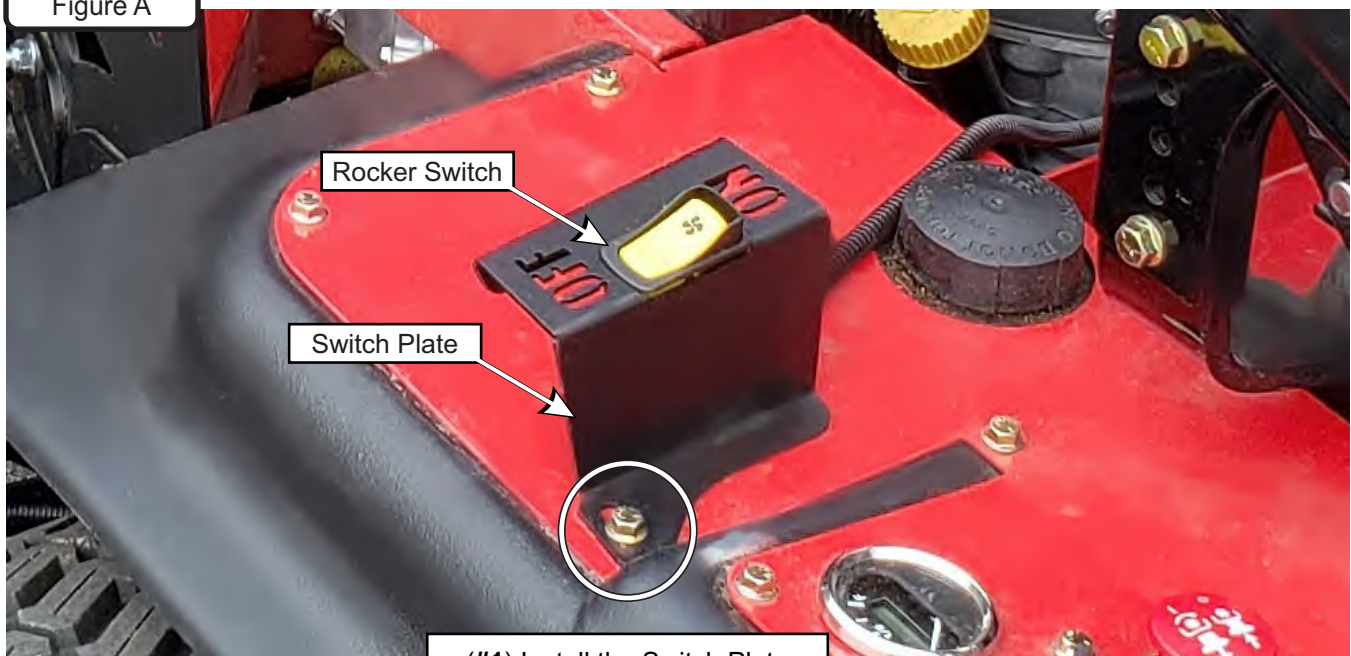
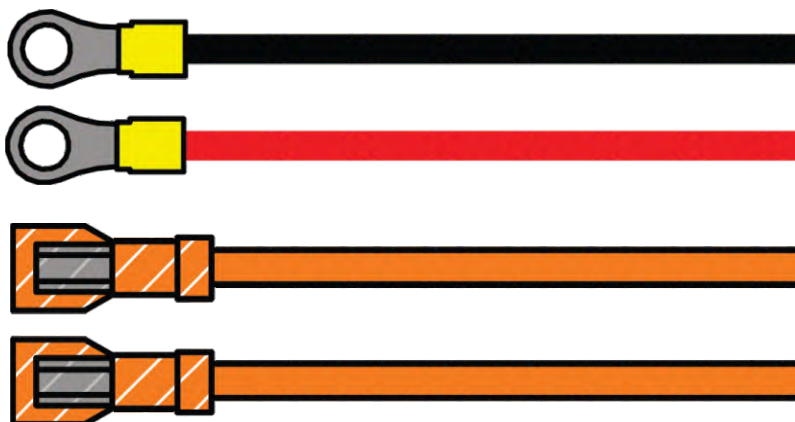

Figure B



Negative Lead (-) to
Negative Terminal (-)

Positive Lead (+) to
Positive Terminal (+)

(2) Female Switch Disconnects
to PTO Rocker Switch

Wire Harness Installation (Continued)

Route the Wire Harness back towards the engine located behind the operator's seat. Disconnect the mower's clutch connector and (#3) interconnect it with the Wire Harness' Clutch Connection Jumper. Refer to Figure C & Figure D. Refer to the Wiring Diagram on Page 28 for the Connection Jumper Types.

Lastly, route the (#4) Wire Harness back towards the rear of the mower positioning the Wire Harness under the Bottom Bracket / Mount Arm. Then connect the Wire Harness to the PTO Unit. Refer to Figure C and Figure E on the next page.

Figure C

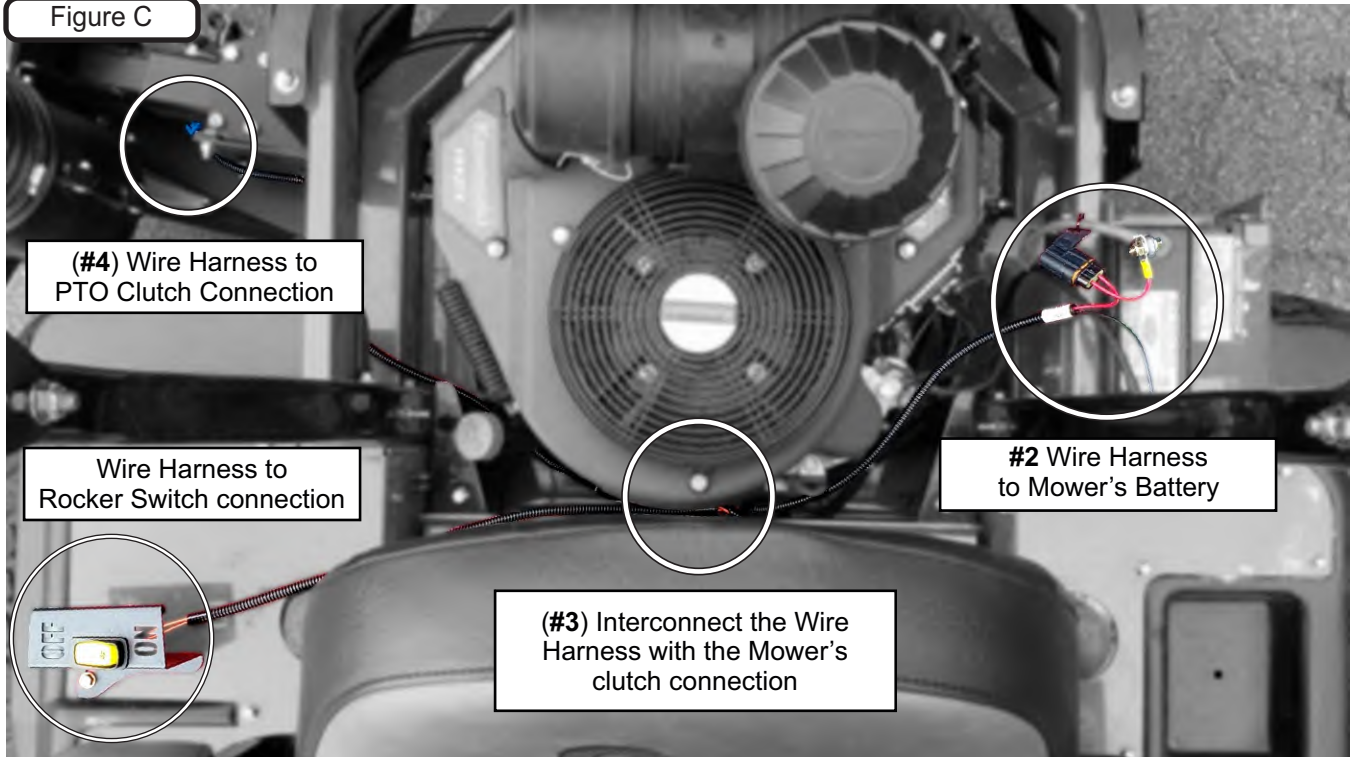
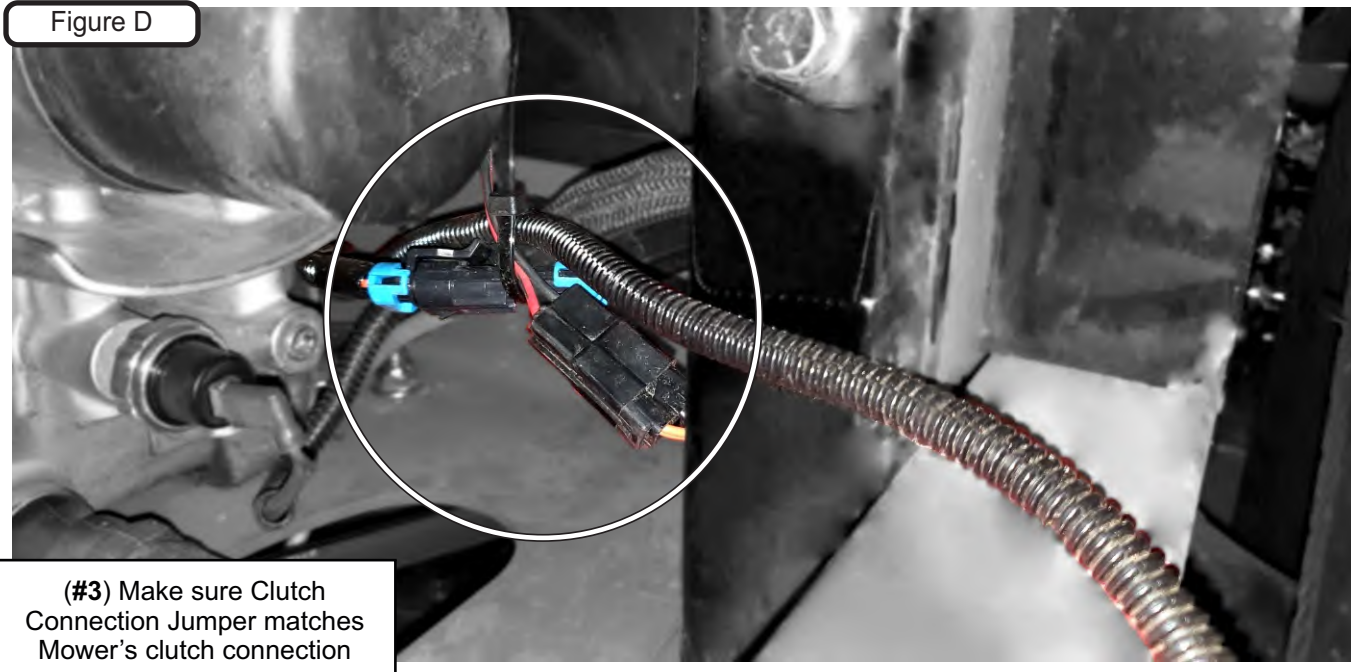

Figure D



Wire Harness Installation (Continued)

Figure E



Note: It is recommended to secure the Wire Harness to the mower by using the included Cable Ties once you have the Wire Harness installed. Be sure the Wire Harness is routed so that it does not obstruct any part of the mower that may damage the Harness.

When routing the Wire Harness back towards the PTO unit, it is recommended to use the Cable Tie point to secure the Wire Harness to the Right Frame Bracket to prevent the Wire Harness from moving. See Figure F below.

Figure F

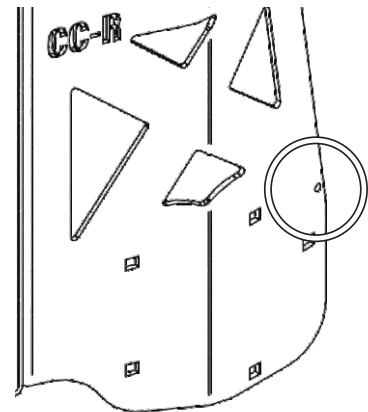

Wire Harness Installation (Continued)

Note: Select the Jumper that fits your mower's clutch connection and connect it to the Wire Harness' Connector Jumper

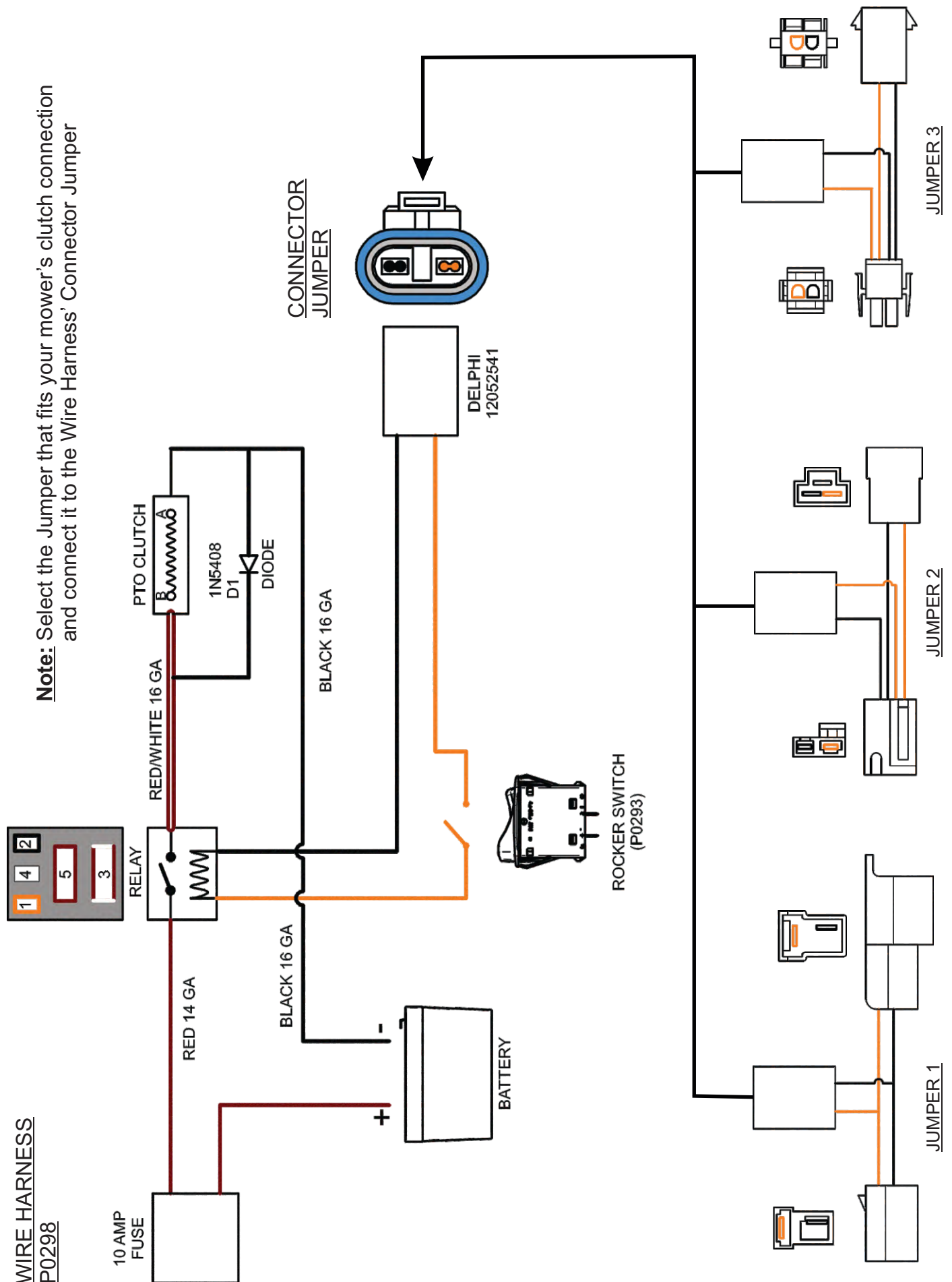

Weight Kit Installation

Position the Quad Weight Bracket Base (Item #2) under the caster tubing w/ opening towards caster fork. Next, position the Weight Bracket Clamp (Item #3) on top of caster tubing w/ opening towards caster fork.

Align the (4) holes of the Weight Bracket Clamp (Item #3) to the holes in the Quad Weight Bracket Base (Item #2). Loosely fasten the Weight Bracket Clamp (Item #3) to the Weight Bracket Base (Item #2) using (4) 5/16"-18 x 3" Bolts (Item #4.1) & (4) 5/16"-18 Ny-Flange Lock Nuts (Item #4.2).

Position the Weight Bracket Base and the Weight Bracket Clamp assembly along the caster tubing to prevent interference from caster forks or any other objects. Tighten the fasteners in an 'X' pattern until assembly is firmly clamped to caster tubing. Do not over tighten which may result in bending Weight Bracket Clamps (Item #3).

To Install the Weights, insert (2) Weights (Item #1) Into the Weight Bracket Base (Item #2) & align the holes of the Weights w/ the holes of the Weight Bracket Base (Item #2). Fasten the Weights (Item #1) to the Weight Bracket Base Using (1) Clevis Pin (Item #4.3) & (1) Hair Pin Clip (Item #4.4). Repeat for additional Weights.

Refer to the Figure Below.

MY2021 : Install all (4) Weights (Item #1) on the Left Caster & ONLY (2) Weights (Item #1) on the Right Caster.

MY2022 : Install all (4) Weights (Item #1) on BOTH the Left & Right Caster.

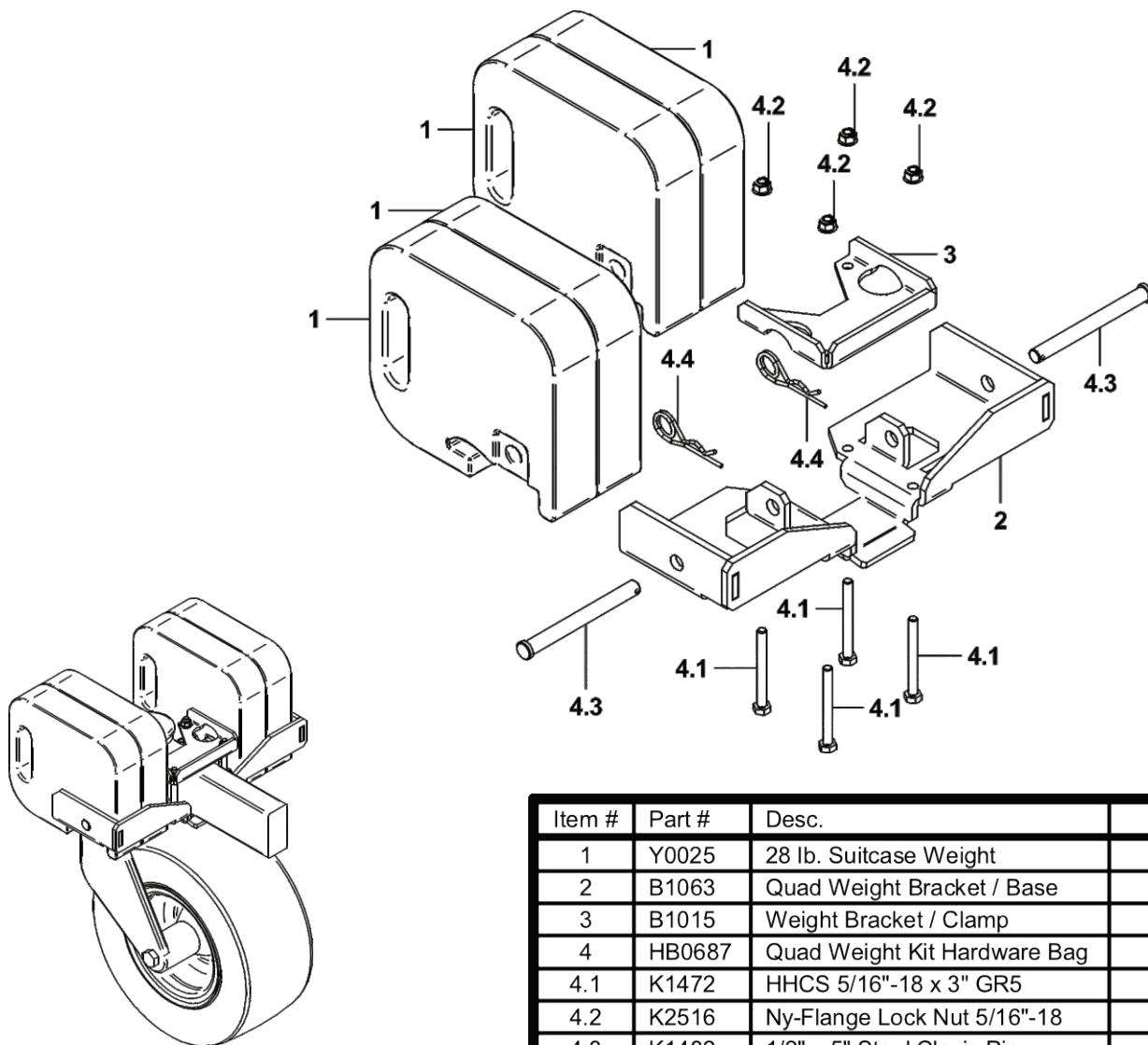

Item #	Part #	Desc.	Qty.
1	Y0025	28 lb. Suitcase Weight	4
2	B1063	Quad Weight Bracket / Base	1
3	B1015	Weight Bracket / Clamp	1
4	HB0687	Quad Weight Kit Hardware Bag	1
4.1	K1472	HHCS 5/16"-18 x 3" GR5	4
4.2	K2516	Ny-Flange Lock Nut 5/16"-18	4
4.3	K1482	1/2" x 5" Steel Clevis Pin	2
4.4	K1478	Hair Pin Cotter / Double Loop	2

Impeller Blade Removal/Replacement

To Remove: First remove the 5/16"-24 x 1" HHCS (#1), Taper Lock Bushing Washer (#3), (2) 5/16 Flat Washers and Spacer Bushing (#4) from the Taper-Lock Bushing (#5). Next remove the (2) 1/4"-20 x 1" HHCS (#2) and place them into the threaded holes of the Taper-Lock Bushing (#5). Gradually thread each bolt evenly into the Taper-Lock Bushing, forcing the blade to break-away from the Taper-Lock Bushing. If the Impeller will not move, carefully hit the base of the Impeller, between each vein, with a hammer, then try again.

To Replace: Place Impeller Blade over the engine shaft. Slide the Taper-Lock Bushing (#5) on to the engine shaft and into the Impeller Blade, aligning the **non-threaded** holes of the Taper-Lock Bushing to the threaded holes of the Impeller Blade. Fasten by using (2) 1/4"-20 x 1" HHCS (#2), (1) Spacer Bushing (#4) (1) Taper-Lock Bushing Washer (#3), and (1) 5/16"-24 x 1" HHCS (#1). Torque to the proper specifications in the torque chart on the back of this manual. Next, rotate the Impeller Blade to ensure that the blade is clear of contact on all sides of the blower housing.

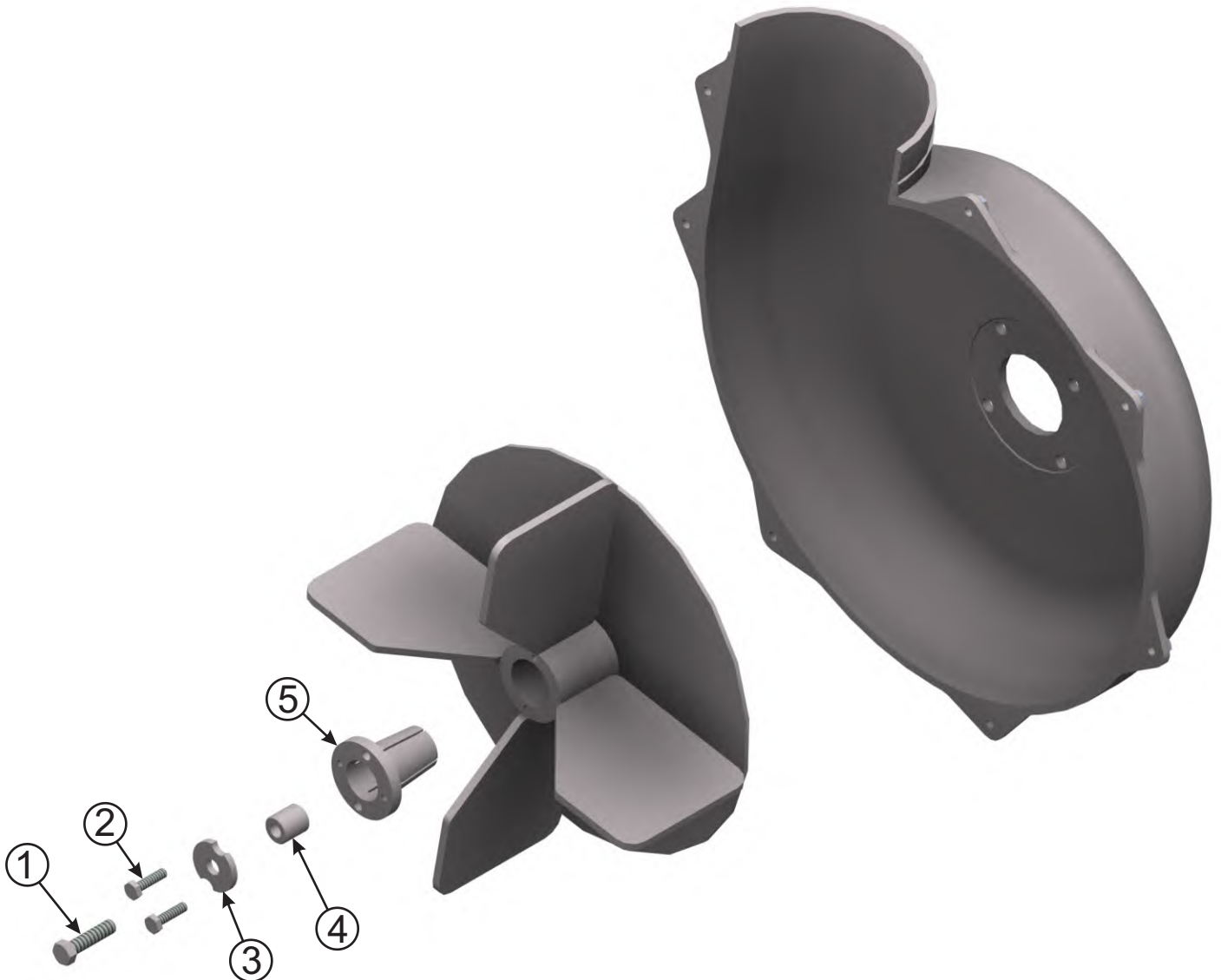

A2207 Mount Arm / Receiver Tube Assy

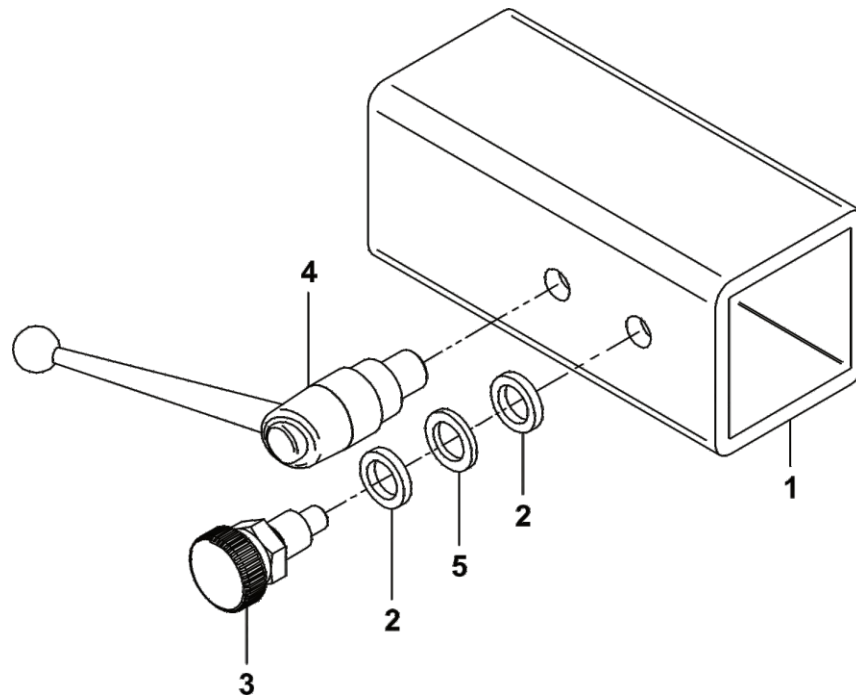

Item #	Part #	Desc.	Qty.
1	B0931	Tube / Mount Arm	1
2	J0013	Nylon Flat Washer 1/2" x .750" OD Grade 6/6	2
3	J0020	Knob Plunger Pin 1/2"-13	1
4	J0009	Adjustable Handle 1/2"-13 x .59 Male	1
5	K0027	Flat Washer 1/2" / .787 OD x .512 ID x .090 T	1

A2092 Idler Arm Assembly

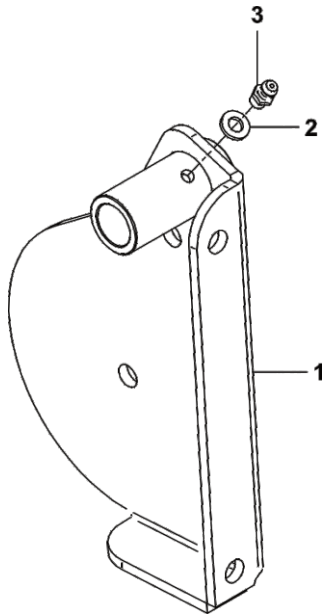

Item #	Part #	Desc.	Qty.
1	A2070_01	Idler Arm Weldment	1
2	K1467	Flat Washer M6 x 12mm OD	1
3	J0801	1/4\"-28 Zirc Fitting	1

A2067_02 Idler Mount Assembly

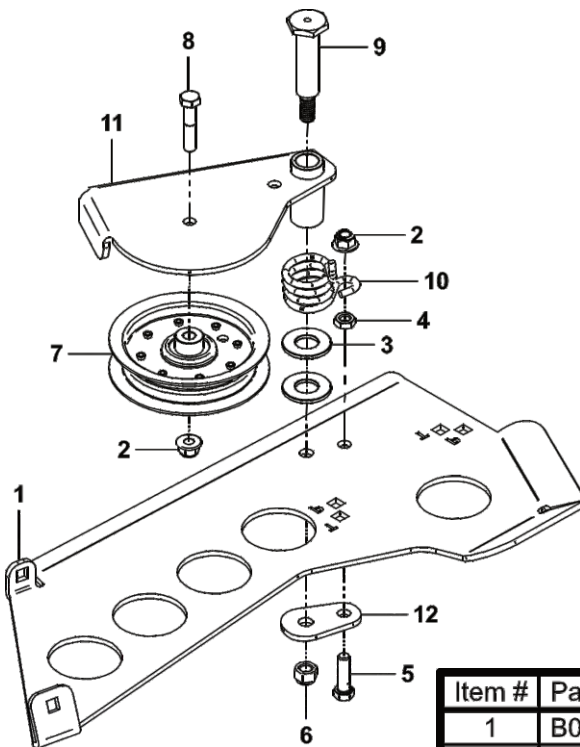

Item #	Part #	Desc.	Qty.
1	B0958_02	Idler Mnt PI	1
2	K2038	Ny-Flange Lock Nut 3/8\"-16	2
3	K1463	Flat Washer .720 ID x 1.500 OD x .250 T	2
4	K1219	Jam Nut 3/8\"-16	1
5	K1192	HHCS 3/8\"-16 x 1-1/4\" GR5	1
6	K0329	Nylock Nut 7/16\"-14 GR8	1
7	M0003	Idler Pulley	1
8	K1462	HHCS 3/8\"-16 x 1-3/4\" GR8	1
9	K1464	Shoulder Bolt 7/16\"-14 / Idler	1
10	J0024	Torsion Spring	1
11	A2092	Idler Arm Assy.	1
12	B0974	Idler Base Plate	1

A2058 Gearbox Sub-Assembly

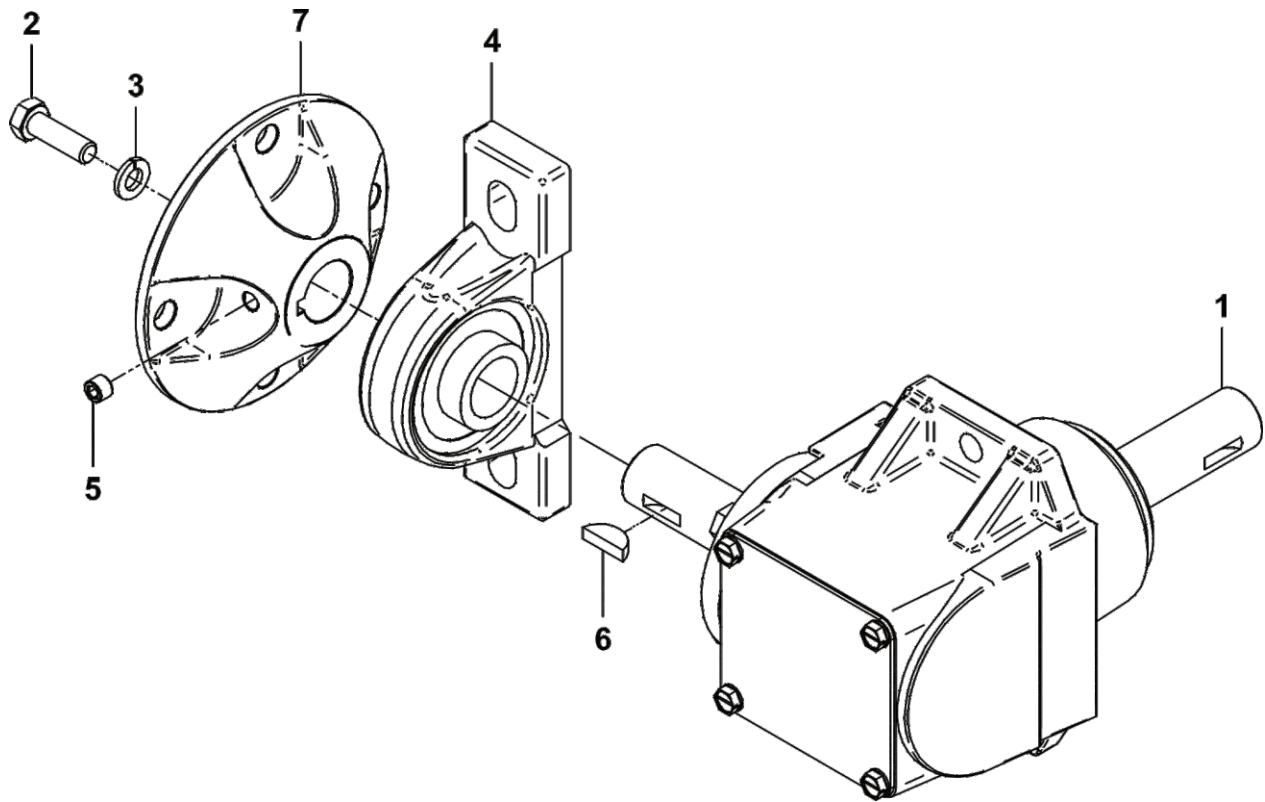

Item #	Part #	Desc.	Qty.
1	M0002	Gearbox	1
2	K0428	HHCS 5/16"-24 x 1" GR8	1
3	K0043	Lock Washer 5/16"	1
4	N0002	Pillow Block Bearing 7/8"	1
5	K0035	Set Screw 5/16"-18 x 1/4" Cup Point	1
6	J0272	Woodruff Key #9	1
7	A2048	Clutch Flange	1

A2059_01 Clutch Sub-Assembly

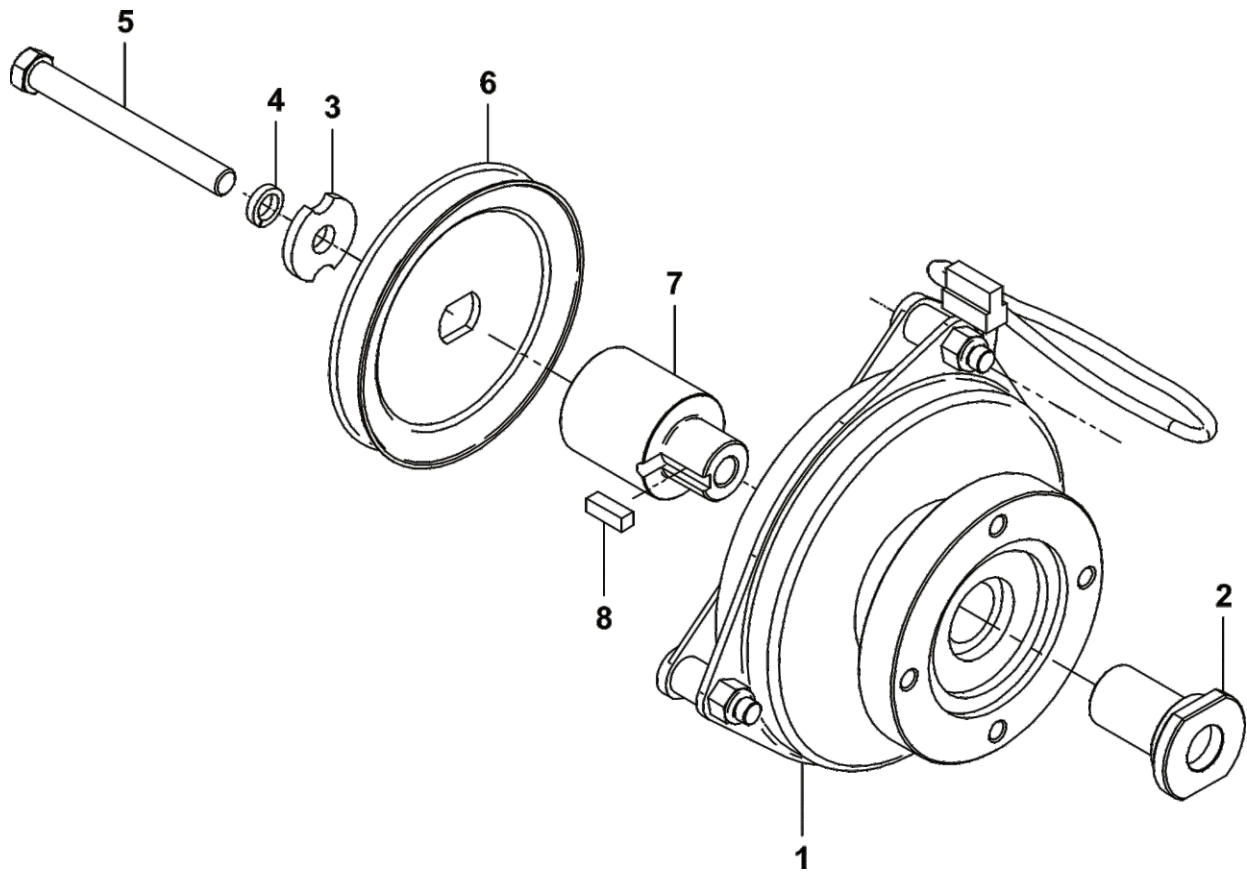

Item #	Part #	Desc.	Qty.
1	M0001	Electric Clutch	1
2	S0007	Clutch Shaft	1
3	K0278	Double Indented Washer 7/16" / 1.375 OD x .440 ID x .179 T	1
4	K0140	Lock Washer 7/16" / High-Collar Helical Spring	1
5	K0550	HHCS / 7/16"-20 x 3.50" w/ Patch	1
6	M0309	A-Section Pulley / 4.75 OD (PTO-X)	1
7	S0221	Eng. Pulley Bushing #27	1
8	K0076	Key 1/4" x 3/4" Long	1

A2057_01 Drive Assembly Exploded Parts View

Item #	Part #	Desc.	Qty.
1	K0048	Lock Washer 3/8"	4
2	K0343	HHCS 3/8"-16 x 7/8" GR8	4
3	A2059_01	Clutch Sub-Assy	1
4	A2058	Gearbox Sub-Assy	1

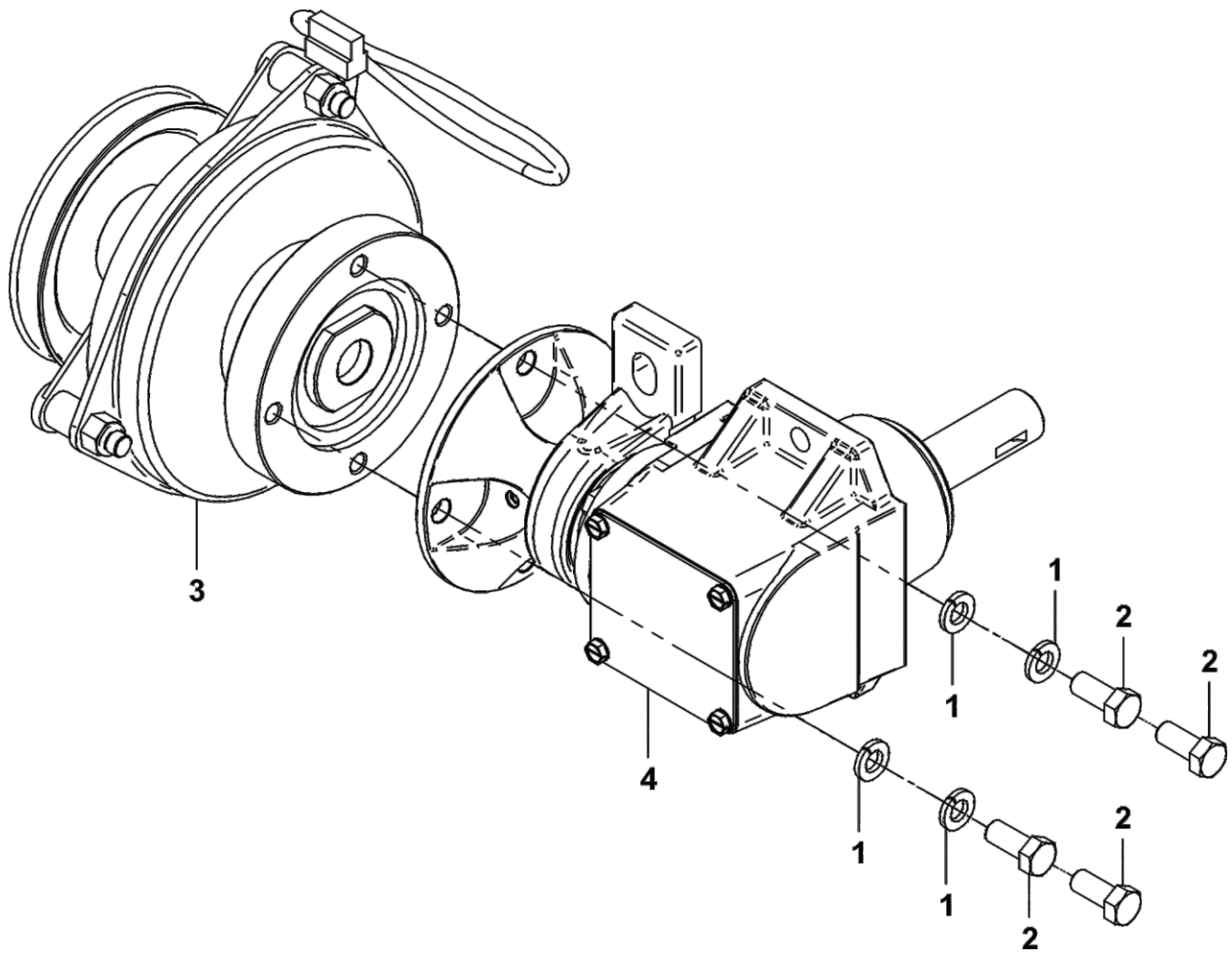

A2060_01 Mounted Drive Assembly

Item #	Part #	Desc.	Qty.
1	B0940	Spacer Plate	1
2	A2034	Drive Mnt Assy	1
3	K0309	3/8"-16 x 1-1/4" SHCS	2
4	K0048	Lock Washer 3/8"	2
5	K0055	Flat Washer 1/2" / 1.383 OD x .560 ID x .120 T	2
6	K0056	Lock Washer 1/2"	2
7	K1234	HHCS 1/2"-13 x 2"	2
8	A2057_01	Drive Assy	1

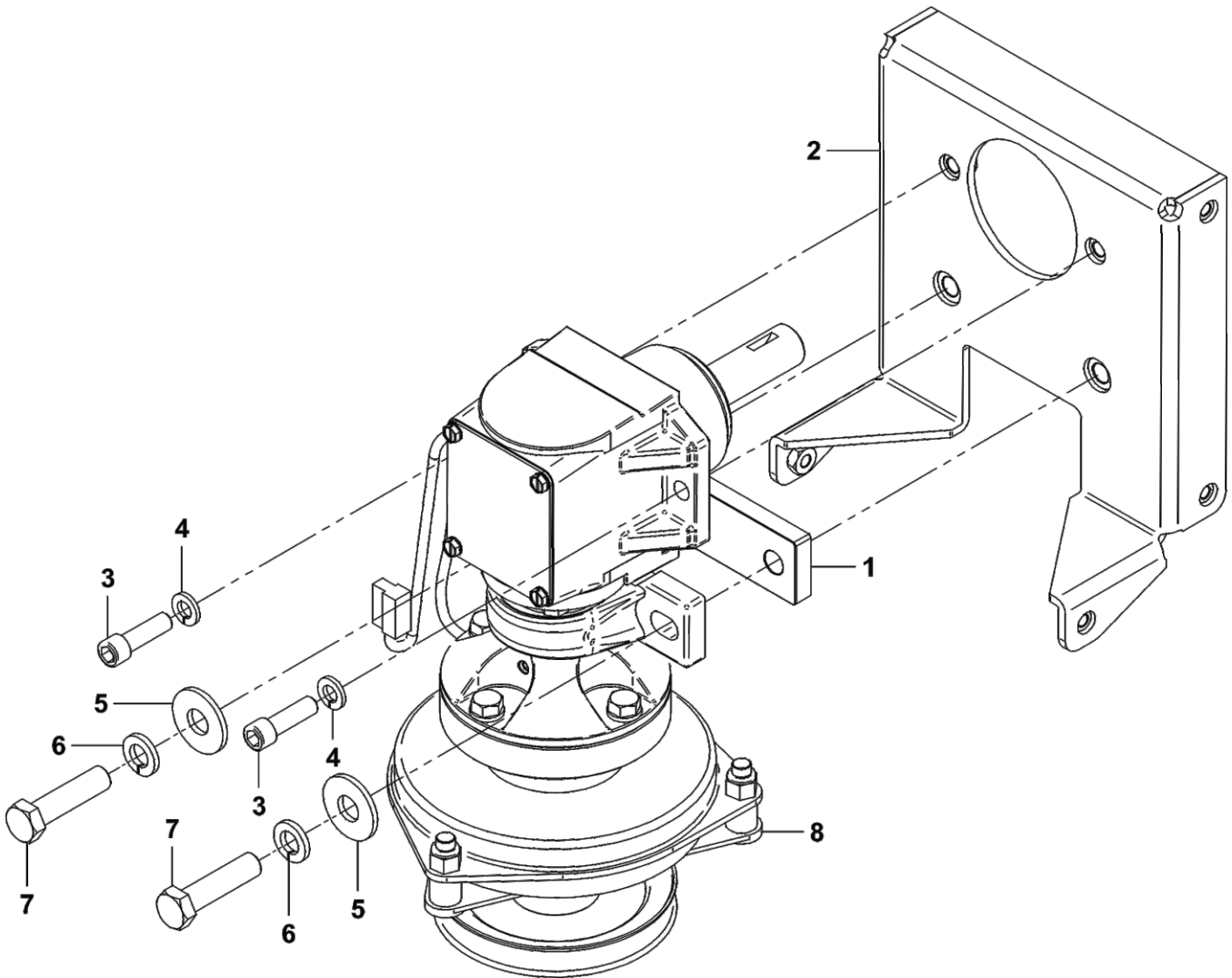

A2039_02 Base Drive Assembly

Item #	Part #	Desc.	Qty.
1	B0938_01	Drive Guard	1
2	A2032	Drive Arm Assy	1
3	A2035_02	Housing Mnt Assy	1
4	B0942_02	Anti-Rotation Brkt	1
5	K1153	HHCS 5/16"-18 x 3/4"	4
6	K0043	Lock Washer 5/16"	8
7	K0353	HWHTCS 1/4"-20 x 1/2"	2
8	K1154	HHCS 5/16"-18 x 1"	4
9	K2516	Ny-Flange Lock Nut 5/16"-18	4
10	A2060_01	Mounted Drive Assy	1
11	P0271	Quick Connect Wire Harness	1
12	K1142	5/16"-18 x 3/4" Carriage Bolt	4
13	K0343	HHCS 3/8"-16 x 7/8" GR8	1
14	K1477	Flat Washer / 3/8" / .406 ID x .812 OD x .125 Thk	1
15	K1476	Reverse Lock Nut / 3/8"-16 Grade C	1
16	B1100	Idler Assy Mount Plate	1

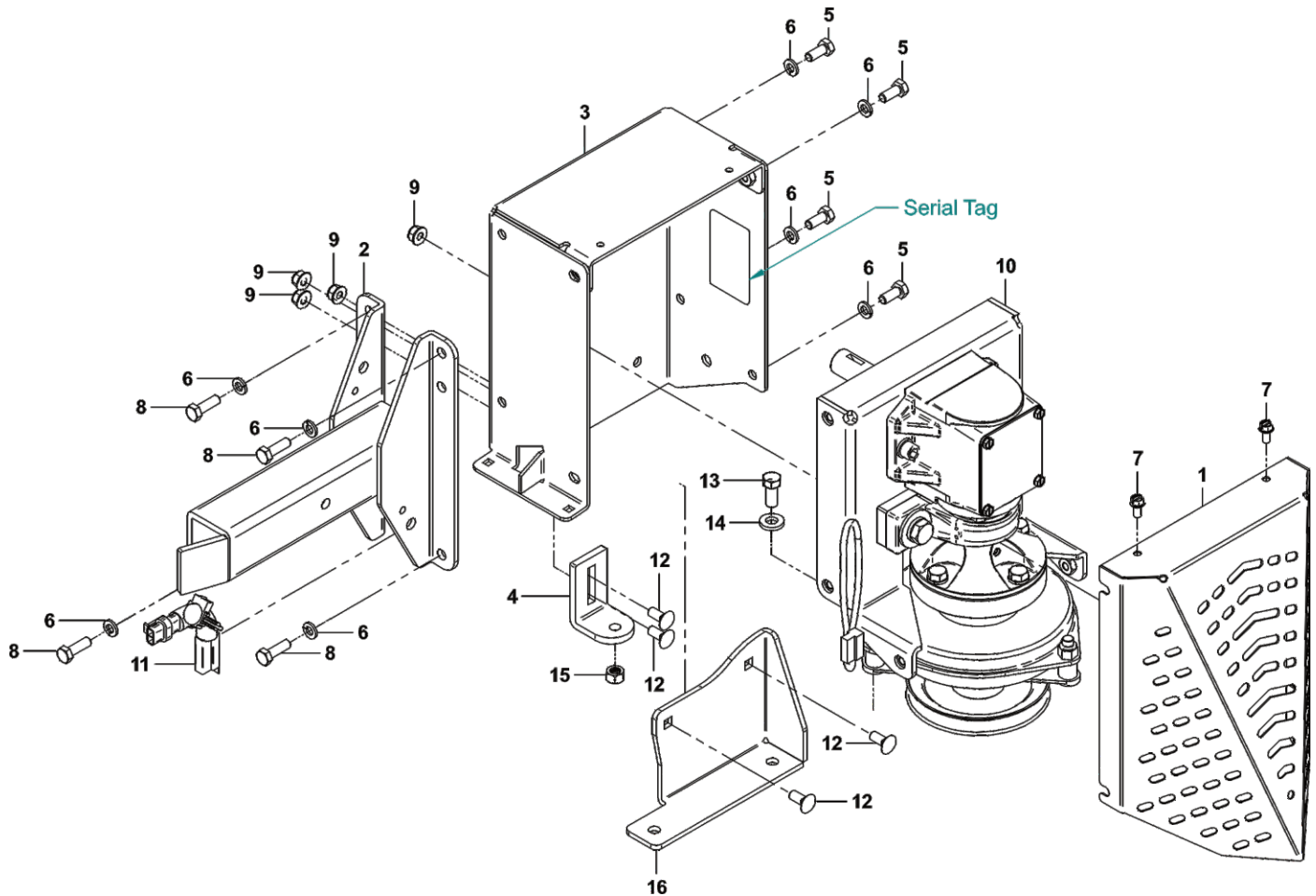

A2061 02 Drive Assembly / 4-Blade Impeller

Item #	Part #	Desc.	Qty.
1	A0645	4-Blade Impeller Weldment	1
2	K0284	Double Indented Washer 3/8" / 1.375 OD x .380 ID x .179 T	1
3	K1465	HHCS 5/16"-24 x 1-1/2" GR8	1
4	K1225	HHCS 1/4"-20 X 1" GR8	2
5	S0159	Spacer Bushing .938 OD x .325 ID x .375 T	1
6	K0044	I/T Tooth Lock Washer 5/16"	4
7	K1154	HHCS 5/16"-18 x 1"	4
8	A2039_02	Drive Assy / Base	1
9	S0157	Taperlock Bushing 7/8"	1
10	K0042	Flat Washer 5/16" / .875 OD x .380 ID x .075 T	2
11	E4052A	Blower Hsg Assy	1
11.1	E4052F	Blower Hsg Front	1
11.2	E4052B	Blower Hsg Back	1
11.3	HB0462	HW Bag / E4004A & E4052A Housings	1
11.3.1	K1401	1/4"-20 x 1" SHCS / Zinc / GR8	7
11.3.2	K1126	Flange Nut 1/4"-20	7

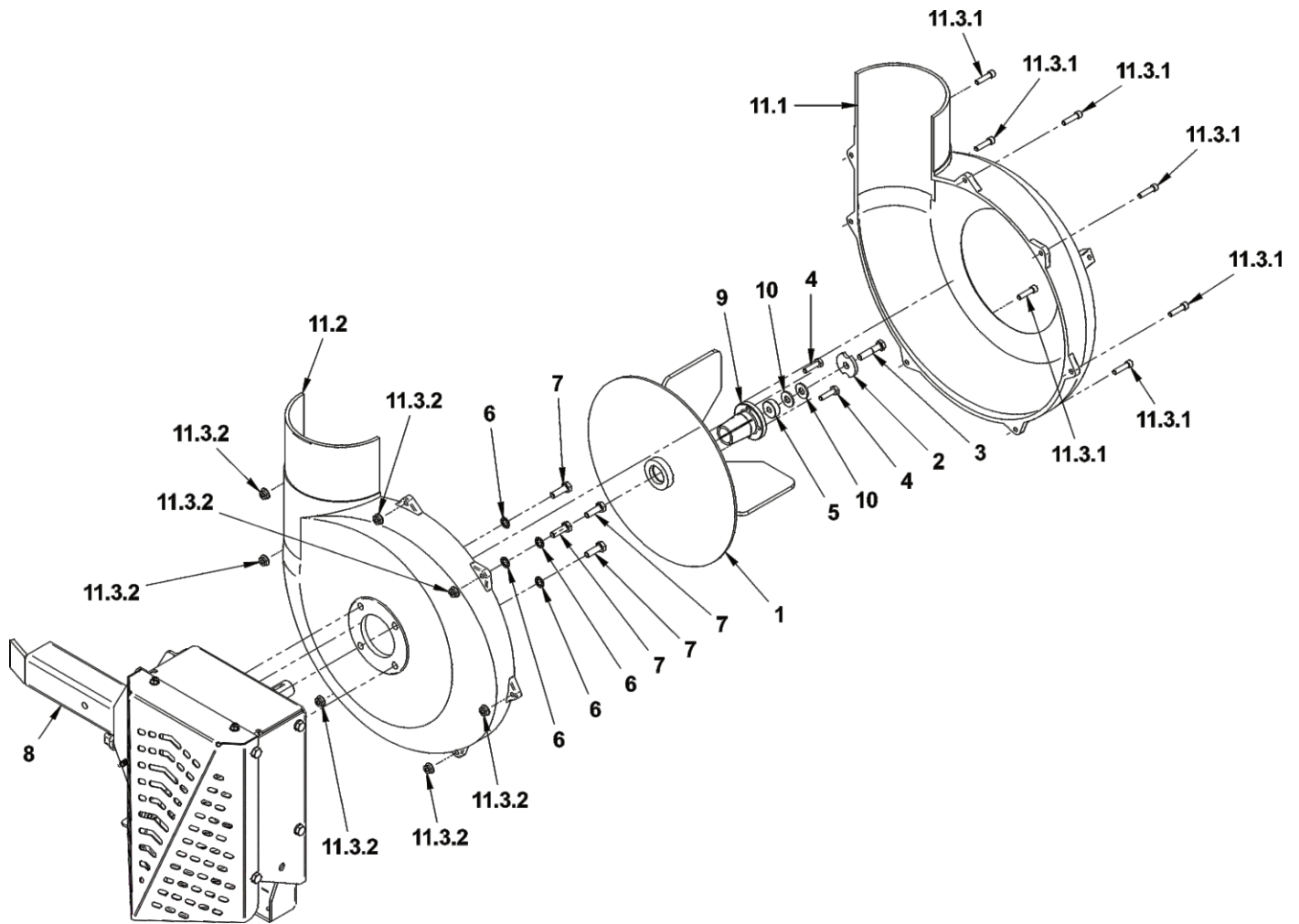

A2100 6512 Box Assembly / Standard
Exploded Parts View

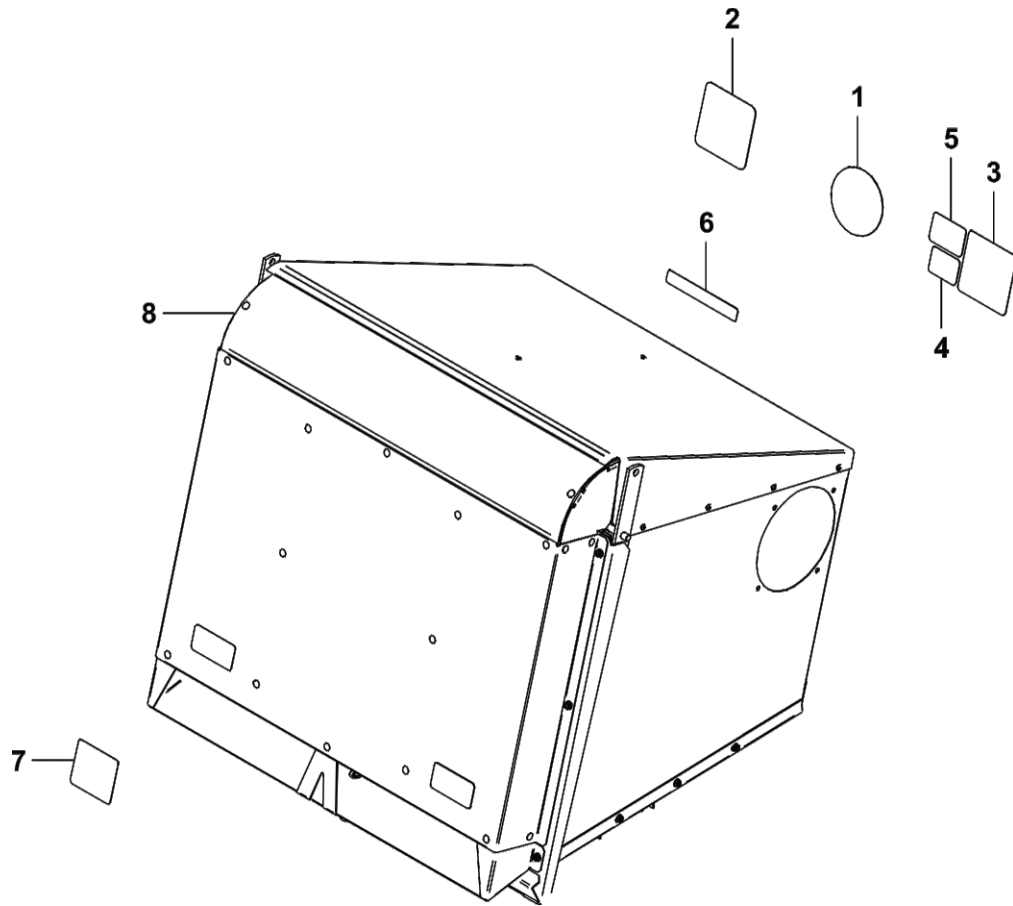

Item #	Part #	Desc.	Qty.
1	R0022	Decal / Built In The USA / Lg	1
2	R0026	Decal / Operation	1
3	R1069	Decal / Warning - Turn Off Blower	1
4	R1051	Decal / Warning - Use Hearing Protection	1
5	R1054	Decal / Important Check Hoses	1
6	R1055	Decal / To Dump Grass	1
7	R1053	Decal / Caution	1
8	A2226	6512 Box Assy. / Base Model	1

A2226 6512 Box Assembly / Base Model

Exploded Parts View

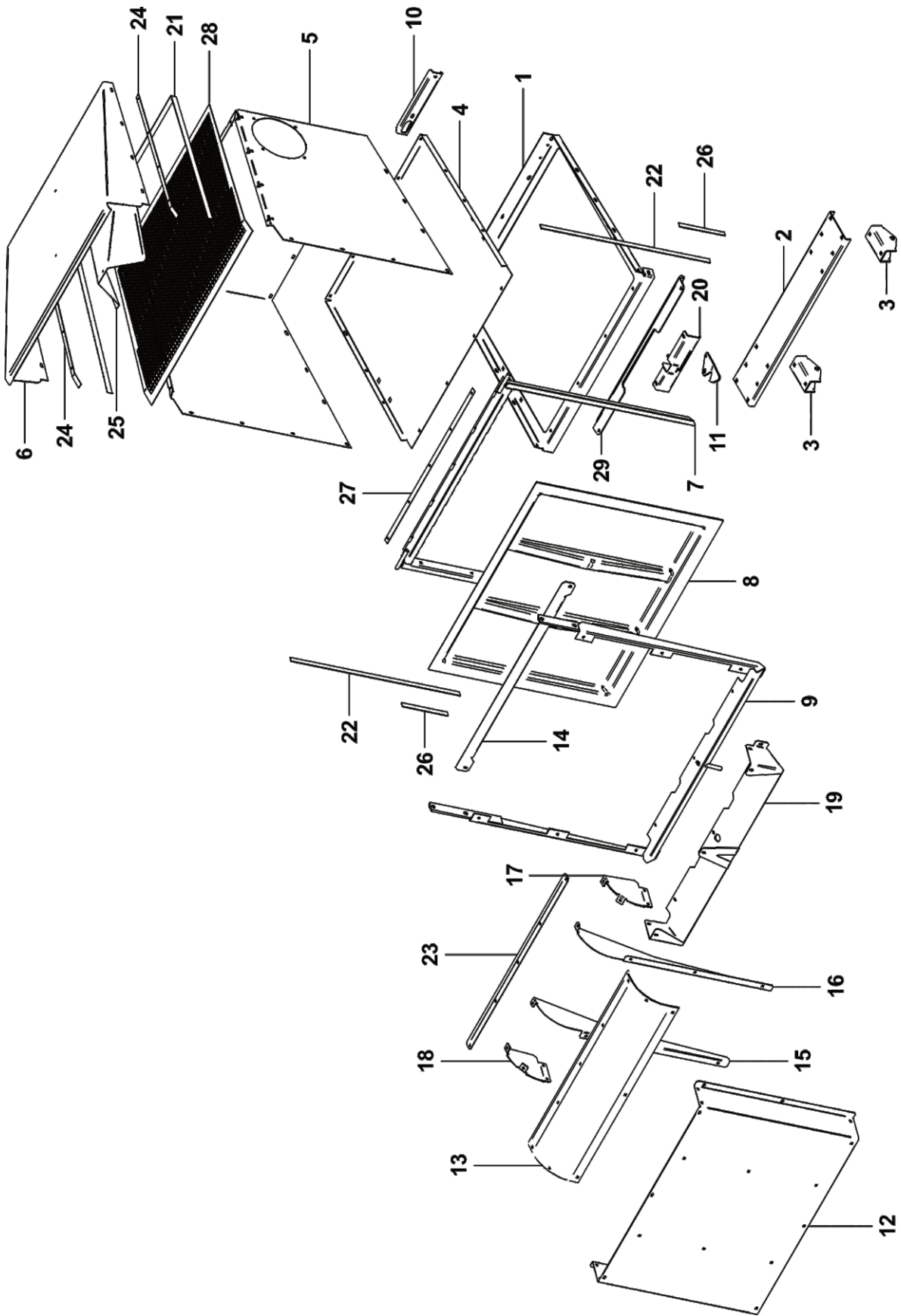

A2226 6512 Box Assembly / Base Model**Exploded Parts List**

Item #	Part #	Desc.	Qty.
1	B1750	Base Frame	1
2	B1727	Base Frame Pivot Mount	1
3	B1574	Pivot Bracket	2
4	C0024	Box Bottom	1
5	C0080	Box Back & Sides	1
6	C0081	Box Top	1
7	A0938	Frame Weldment / Box Opening	1
8	V1131	12 Box Door	1
9	A0738	Frame Weldment / Door Stiffener	1
10	B1730	Latch Handle Mount Bracket	1
11	B0996	Latch Hook	1
12	C0075	Dust Diverter	1
13	V0051	Dust Flap	1
14	B3688	Upper Door Member	1
15	C0076	Left Dust Diverter Brace	1
16	C0077	Right Dust Diverter Brace	1
17	C0079	Right Outer Dust Flap Brace	1
18	C0078	Left Outer Dust Flap Brace	1
19	B0991	Dust Diverter Guard Bracket	1
20	A2104	Latch Mount Plate Assy.	1
21	V0052A	Dust Seal / Top Sides	1
22	V0052B	Dust Seal / Long Door Sides	2
23	B1006	Dust Flap Stiffener	1
24	B1007	Screen Clamp Strip / Side	2
25	C0087	Screen Support	1
26	V0052C	Dust Seal / Short Door Sides	2
27	B1008	Screen Clamp Strip / Rear Door	1
28	B8113	Screen / Steel Wire Mesh	1
29	B2021	Box Stop / 6512	1

A2107 Latch Rod Assembly
Exploded Parts View

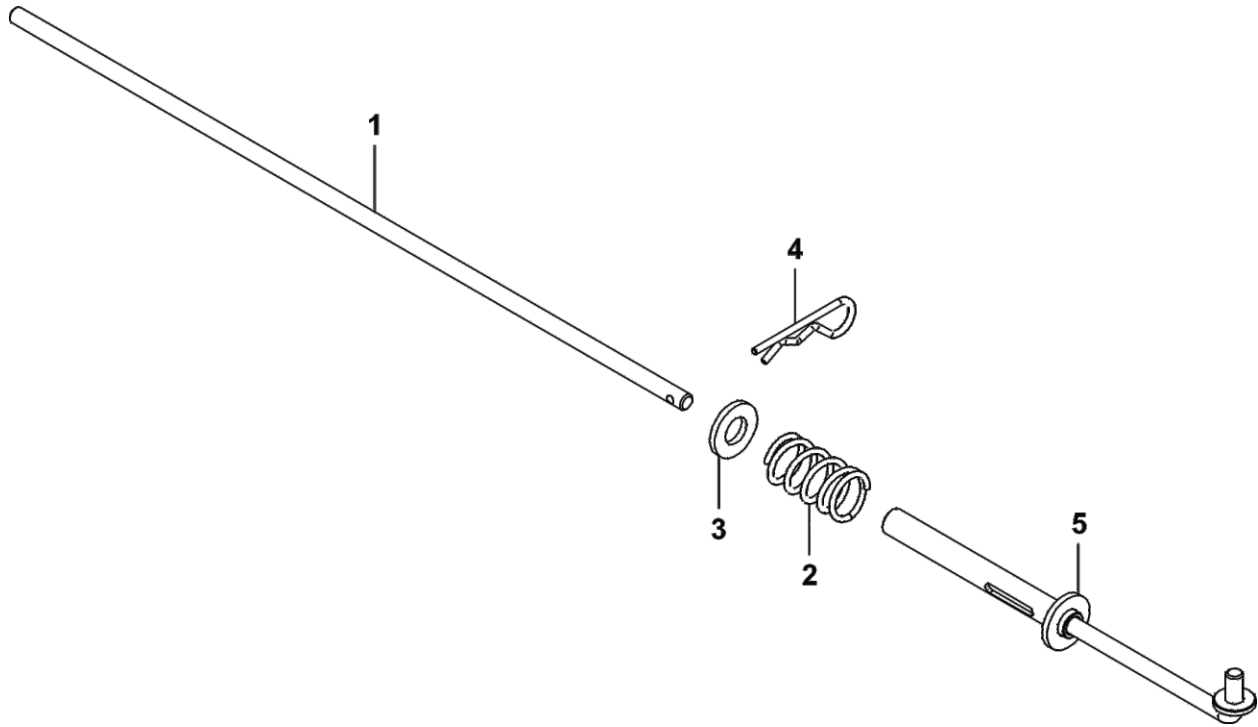

Item #	Part #	Desc.	Qty.
1	B1000	Latch Rod / Hook Side	1
2	J0303	Spring	1
3	K0400	1/2" Flat Washer 1.084 OD x .528 ID x .120 T	1
4	K0086	Hair Pin Clip .125 OD x 2.50	1
5	A2106	Latch Rod Weldment	1

Unit Model #: 49651202

Mower: Country Clipper

Owner's Manual: Q0575

Mower Type: Charger 8000 & 8005 series / Boss XL 9000 & 9005 series

Deck Size: 60"

Vac Type: Pro12 DFS

Deck Type:

Drive Type: PTO-X

Revision #: 1 - Updated for 2022 MY - XY (April 2021)

Fits Year(s): 2021-Newer

A2329 Vac Kit

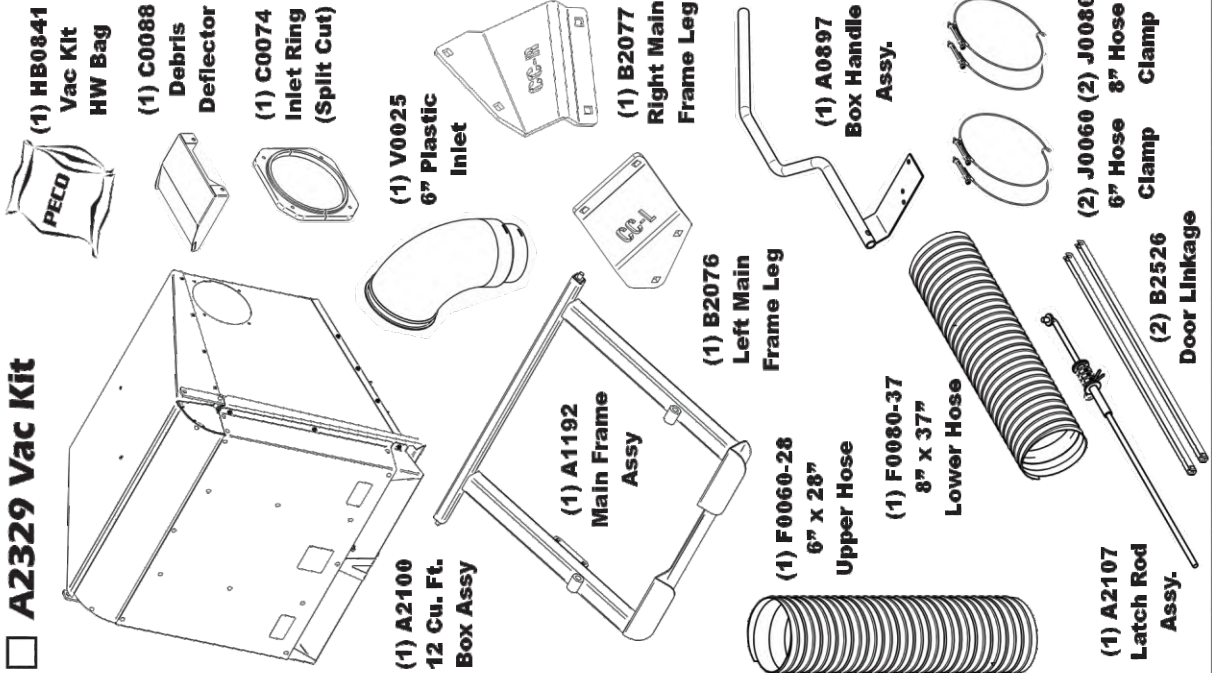

A2327 Mount Kit

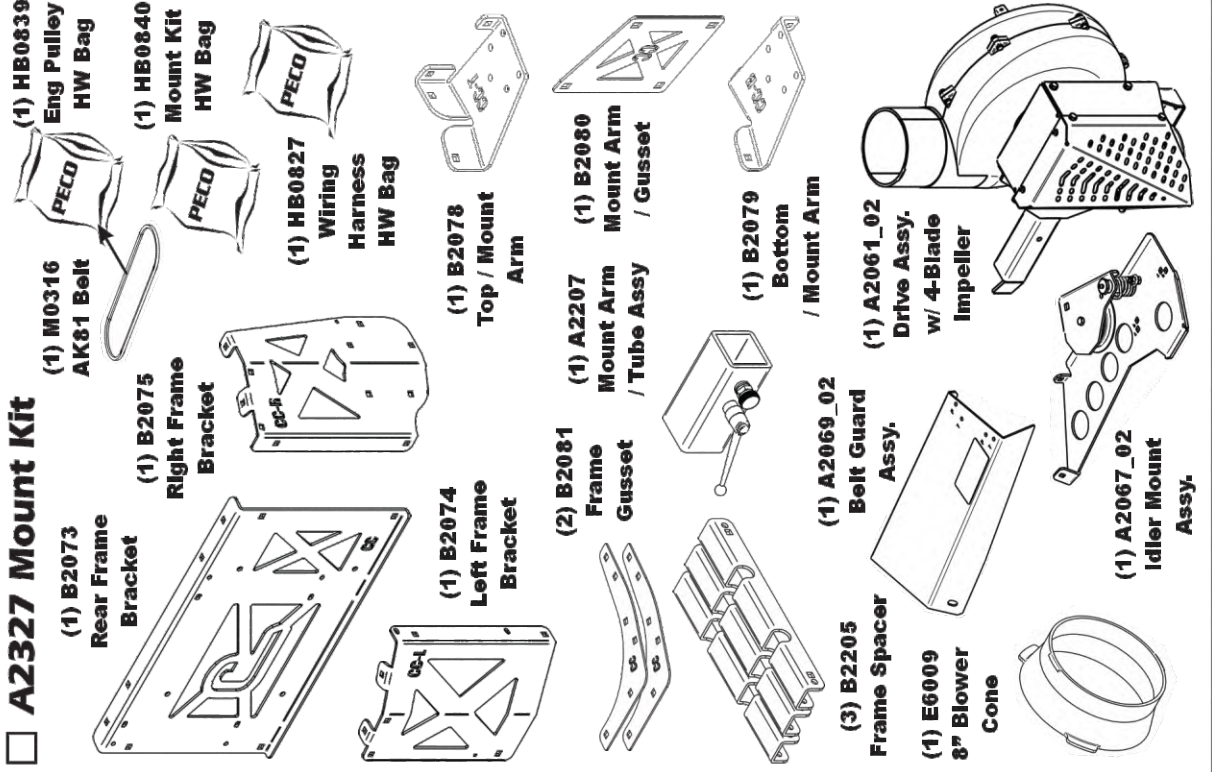

A2159 Boot Kit

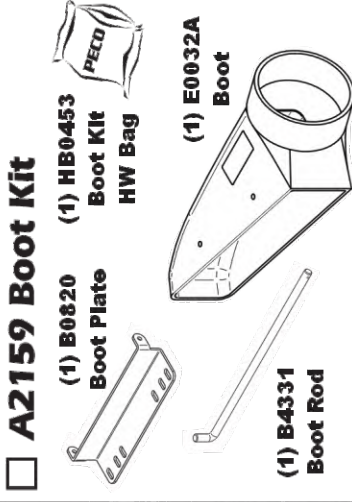

A2162 Quad Weight Kit

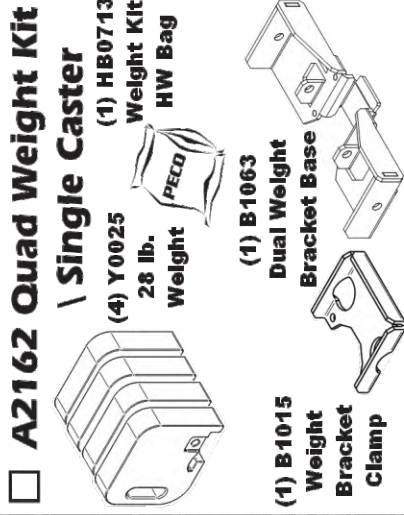

A2162 Quad Weight Kit

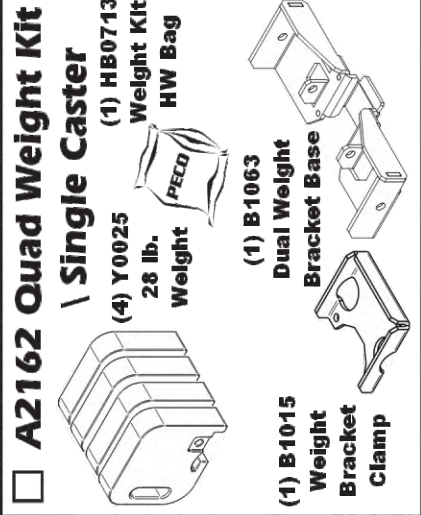

SAFETY DECALS

To promote safe operation, New PECO, Inc. supplies safety decals on all products manufactured. Damage can occur to safety decals either through shipment, use or reconditioning. Contact your local Service Center for replacement decals.



Part# R1070
PECO Logo



Part# R0022
Designed & Built
In The USA



Part #: R2007
Danger - Never Use Hands



Part #: R2008
Danger - Rotating Blades



Part #: R1054
Important - Hose Wear

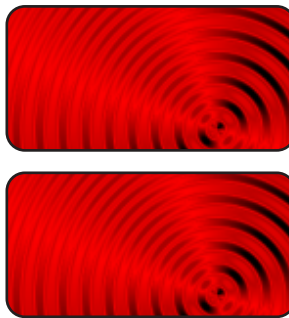

Part #: R1057 - (2)
Red Reflectors



Part #: R1069
Warning - Turn Off Blower



Part # R0024
Danger - Keep Hands
Clear



Part #: R1051
Warning - Hearing
Protection



Part # R0025
Danger - Rotating
Blades

SECTION III

OPERATING INSTRUCTIONS

General Safety

Only qualified people familiar with this operator's manual and the mower's operator's manual should operate this machine.

Operation And Tips On Mowing

- A. Perform BEFORE EACH USE the maintenance list referenced in Section IV.
- B. Start mower.
- C. With the mower at high idle speed, engage the mower deck.
- D. While seated in the operator's seat, move Bagger PTO switch to the on position. With the PTO assembly engaged, you can proceed to operate the control levers of the mower.

NOTE: If the collection system does not appear to be collecting the grass clippings, disengage the deck and PTO assembly, then, engage the parking brake and turn the mower off. Check upper and lower hoses for any clogs.

To obtain the maximum effectiveness from your collection system, the tips listed below should be followed:

- * Watch your speed- Normal conditions will allow a speed of up to approximately 4 mph, but thick, heavy damp conditions will require reduced ground speed.
- * Mow with sharp blades- A sharp blade cuts cleaner.
- * Wet grass and leaves will decrease effectiveness and will increase horsepower requirements.
- * Mow at higher cutting heights- Remove and mulch no more than 2" of grass length with each mowing. (Experts recommend not cutting off more than 1/3 of the grass blade length at any given time.)
- * Mow twice, at different height settings, (high, then low), if grass is extra tall.
- * Remember that horsepower requirements will vary with the mowing conditions such as type and height of turf grass, moisture content, amount of leaves, whether the terrain is flat or hilly, etc.

Disengagement Of The PTO Assembly

- A. To disengage the PTO assembly, move Bagger PTO switch to the off position.

WARNING: DO NOT TOUCH the PTO assembly, pulleys, or the belt until the tractor is turned off.

Unloading The Collection System

- A. Stop the forward movement of the mower, engage the parking brake.
- B. Disengage the mower deck.
- C. Disengage the blower.
- D. Verify that the dump area is clear.
- E. Push the dump handle, on the left of the operator, away from the unit. While holding the handle pushed away, move the handle upward. The container door will swing upward and the container will rotate downward. The container will release its contents.
- F. Once the contents of the container have fallen out, the container is ready to move back into its normal operating position. Pull the handle downward until positive latching is achieved.

NOTE: Do not allow collection system to become over-filled as potential damage may occur to your equipment. Also, be sure to clean the screen as needed.

SECTION IV

MAINTENANCE

Maintenance Checklist

Before each use:

1. Check blades and spindles to be sure that no foreign objects, such as wire or steel strapping bands, are wrapped around them.
2. Inspect blades for wear. Replace if necessary. If it is necessary to sharpen the blades, remove the blades from the spindles before sharpening. DO NOT sharpen blades while still attached to the mower.

3. Make sure all shields are in place and in good condition. Repair or replace any missing or damaged shields.
4. Perform lubrication per instructions.
5. Listen for abnormal sounds, which might indicate loose parts, damaged bearings, or other damage. Correct any deficiency before continuing operation.
6. With the engine off, engage the blower assembly. Check the belt tension and inspect the pulley belt for cracks or tears.
7. Check for wear or deterioration of the upper or lower hoses. If there are any portions of the hose that have been torn or worn through, replace immediately.

After Each Use:

1. Clean all debris from machine especially from the container, underneath the belt shields, and safety decals. Replace any missing or illegible decals.
2. Inspect the unit for worn or damaged components. Repair or replace before the next use. Any replacement component installed during repair shall include the component's current safety decal specified by the manufacturers to be affixed to the component.
3. Under normal usage, the collection unit is subject to deterioration and wear. Inspect the unit for worn or damaged components. Repair or replace before the next use. Any replacement component installed during repair shall include the component's current safety decal specified by the manufacturers to be affixed to the component.
4. Check belt for proper tension.

Lubrication

Gearbox:

NOTE: The gearbox is filled with 6.0 oz. of Mobilube HD Plus 80W-90 oil and permanently sealed. There is no need for scheduled lubrication. The oil level should only be checked if a leak is observed or if a change in gearbox noise is noticed.

Operators are recommended to check for leaks weekly, if a leak is observed, both the gasket and the seals are recommended to be replaced.

Replace the oil using 5.5 oz. of the recommended Mobilube HD Plus 80W-90 oil. Be sure to not overfill.

Blower Assembly:

NOTE: The following is for older PTO models that contain a greaseable zerk fitting. Newer models contain maintenance-free bearings and are without a greasable fitting.

1. On initial use: Grease the fitting on the blower shaft.
2. Every 25 hours of use: Re-grease the grease fitting.

NOTE: Use only white lithium based grease for lubrication of the shaft on the blower assembly.

SECTION V - PARTS & SERVICE

Parts And Service Information

Collection system owners should record the name and telephone number of their Service Center. Your Service Center will be happy to supply replacement parts, accessories, and do any service or repairs to your collection system. If for any reason your Service Center is unable to service your collection system or supply replacement parts, contact New PECO, Inc. and include the following information on the chart below.

DOCUMENT THE FOLLOWING INFORMATION FOR FUTURE REFERENCE

Unit Model Number: _____

Unit Engine Size: _____

Unit Serial Number: _____

Date of purchase: ____ / ____ / ____

Dealer/Distributor Name: _____

Address: _____ **State:** _____ **Zip:** _____

Phone Number: _____

New PECO, Inc.

10 Walden Dr | Arden, North Carolina 28704

Phone: 1-800-438-5823 | 828-684-1234

Fax: 828-684-0858

Email: peco@lawnvac.com

Website: www.lawnvac.com

TORQUE SPECIFICATIONS

Proper torque for American fasteners used on Peco equipment.
Recommended Torque in Foot Pounds (Newton Meters).*

AMERICAN

Bolt Head Markings

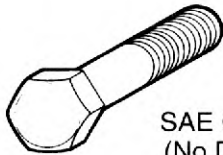

SAE Grade 2
(No Dashes)

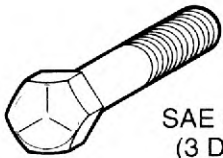

SAE Grade 5
(3 Dashes)

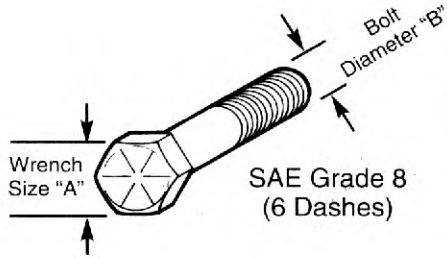

SAE Grade 8
(6 Dashes)

WRENCH SIZE (IN.) "A"	BOLT DIAMETER (IN.) "B" AND THREAD SIZE	SAE GRADE 2	SAE GRADE 5	SAE GRADE 8
7/16	1/4 - 20 UNC	6 (7)	8 (11)	12 (16)
7/16	1/4 - 28 UNF	6 (8)	10 (13)	14 (18)
1/2	5/16 - 18 UNC	11 (15)	17 (23)	25 (33)
1/2	5/16 - 24 UNF	13 (17)	19 (26)	27 (37)
9/16	3/8 - 16 UNC	20 (27)	31 (42)	44 (60)
9/16	3/8 - 24 UNF	23 (31)	35 (47)	49 (66)
5/8	7/16 - 14 UNC	32 (43)	49 (66)	70 (95)
5/8	7/16 - 20 UNF	36 (49)	55 (75)	78 (106)
3/4	1/2 - 13 UNC	49 (66)	76 (103)	106 (144)
3/4	1/2 - 20 UNF	55 (75)	85 (115)	120 (163)
7/8	9/16 - 12 UNC	70 (95)	109 (148)	153 (207)
7/8	9/16 - 18 UNF	79 (107)	122 (165)	172 (233)
15/16	5/8 - 11 UNC	97 (131)	150 (203)	212 (287)
15/16	5/8 - 18 UNF	110 (149)	170 (230)	240 (325)
1-1/8	3/4 - 10 UNC	144 (195)	266 (360)	376 (509)
1-1/8	3/4 - 16 UNF	192 (260)	297 (402)	420 (569)
1-5/16	7/8 - 9 UNC	166 (225)	430 (583)	606 (821)
1-5/16	7/8 - 14 UNF	184 (249)	474 (642)	668 (905)
1-1/2	1 - 8 UNC	250 (339)	644 (873)	909 (1232)
1-1/2	1 - 12 UNF	274 (371)	705 (955)	995 (1348)
1-1/2	1 - 14 UNF	280 (379)	721 (977)	1019 (1381)
1-11/16	1-1/8 - 7 UNC	354 (480)	795 (1077)	1288(1745)
1-11/16	1-1/8 - 12 UNF	397 (538)	890 (1206)	1444 (1957)
1-7/8	1-1/4 - 7 UNC	500 (678)	1120 (1518)	1817 (2462)
1-7/8	1-1/4 - 12 UNF	553 (749)	1241 (1682)	2013 (2728)
2-1/16	1-3/8 - 6 UNC	655 (887)	1470 (1992)	2382 (3228)
2-1/16	1-3/8 - 12 UNF	746 (1011)	1672 (2266)	2712 (3675)
2-1/4	1-1/2 - 6 UNC	870 (1179)	1950 (2642)	3161 (4283)
2-1/4	1-1/2 - 12 UNF	979 (1327)	2194 (2973)	3557 (4820)

METRIC

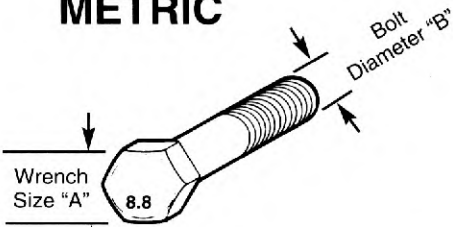

Numbers appearing on bolt heads indicate ASTM class.

Proper torque for metric fasteners used on Peco equipment.
Recommended torque in foot pounds (newton Meters).*

WRENCH SIZE (mm) "A"	BOLT DIA. (mm) "B"	ASTM 4.6	ASTM 8.8	ASTM 9.8	ASTM 10.9
8	5	1.8 (2.4)		5.1 (6.9)	6.5 (8.8)
10	6	3 (4)		8.7 (12)	11.1 (15)
13	8	7.3 (10)		21.1 (29)	27 (37)
16	10	14.5 (20)		42 (57)	53 (72)
18	12	25 (34)	74 (100)	73 (99)	93 (126)
21	14	40 (54)	118 (160)	116 (157)	148 (201)
24	16	62 (84)	167 (226)	181 (245)	230 (312)
30	20	122 (165)	325 (440)		449 (608)
33	22		443 (600)		611 (828)
36	24	211 (286)	563 (763)		778 (1054)
41	27		821 (1112)		1138 (1542)
46	30	418 (566)	1119 (1516)		1547 (2096)

*Use 75% of the specified torque value for plated fasteners. Use 85% of the specified torque values for lubricated fasteners.

Troubleshooting

2017 (v1.0)

Collection System Performance

Problem	Possible Cause	Corrective Action
Abnormal Vibration	<ul style="list-style-type: none"> • Cutting blades are bent or unbalanced • Loose blower pulley or pulley assembly • Impeller blade out of balance 	<ul style="list-style-type: none"> • Install new cutting blade • Tighten the pulley • Contact dealer to replace
Reduced collection system performance	<ul style="list-style-type: none"> • Low engine speed • Plugged screen • Loose belt • Full collection bags 	<ul style="list-style-type: none"> • Always operate collection system at full throttle • Remove debris, leaves, or grass clippings from the screen • Replace/tighten belt • Empty the collection bags
Blower and hoses plugging too frequently	<ul style="list-style-type: none"> • Collection bags are too full • Low engine speed • Grass is too wet • Grass is too long • Ground speed is too fast • Worn belt • Loose belt 	<ul style="list-style-type: none"> • Dump more frequently • Always operate collection system at full throttle • Cut grass when it is dry • Cut the grass several times • Drive slower at full throttle • Replace belt • Adjust the pulley and tighten belts
Debris blowout	<ul style="list-style-type: none"> • Collection bags are too full • Plug/clog in the collection system • Ground speed is too fast 	<ul style="list-style-type: none"> • Dump more frequently • Clean the collection system • Drive more slowly at full throttle
Impeller doesn't rotate freely	<ul style="list-style-type: none"> • Plug in the blower housing • Worn impeller blade • Shaft bearings bad/failing 	<ul style="list-style-type: none"> • Clean the blower housing • Contact dealer to replace • Contact dealer to replace



New PECO, Inc.

10 Walden Dr | Arden, North Carolina 28704

Phone: 1-800-438-5823 | 828-684-1234

Fax: 828-684-0858

Email: peco@lawnvac.com

Website: www.lawnvac.com